



# ACTUAL PROBLEMS OF MODERN SCIENCE, EDUCATION AND TRAINING

**KHOREZMSCIENCE.UZ**





## CONTENTS

<b>Section 1. MODERN PROBLEMS OF PEDAGOGY AND PSYCHOLOGY.....</b>	<b>4</b>
<b>QUCHQOROVA NARGIZA MAMAJONOVNA /// PRACTICAL ANALYSIS OF THE DEVELOPMENT OF ECONOMIC COMPETENCE OF STUDENTS OF THE PRESCHOOL EDUCATIONAL DIRECTION.....</b>	<b>4</b>
<b>MAKHKAMOVA SAODAT BAKHTIYAROVNA /// PREPARING FUTURE TEACHERS FOR ARTISTIC GAFUR ABDURAKHMANOV ANALYSIS OF WORKS OF FINE ART IN SCHOOL.....</b>	<b>9</b>
<b>TILLYASHAYKHOVA MAKHSUDA ABDUSATTAROVNA /// TECHNOLOGY OF CREATING ELECTRONIC EDUCATIONAL TOOLS USING MULTIMEDIA TECHNOLOGIES.....</b>	<b>15</b>
<b>ZOKIROV BAHODIR SHAVKATOVICH /// ORGANIZING THE METHODOLOGY OF TEACHING THE SCIENCE “ACCESS TO SCIENCE” ON THE BASE OF INNOVATIVE TECHNOLOGIES.....</b>	<b>20</b>
<b>ISROILOVA DILDORA MUKHTOROVNA /// INTERNATIONALIZATION OF CURRICULUM IN FORMATION OF INTERCULTURAL COMPETENCE OF ENGINEERING STUDENTS.....</b>	<b>25</b>
<b>RUZIYEVA MUHAYYO ERKINOVNA /// PEDAGOGICAL ASPECTS OF RESEARCHING THE LIFESTYLE OF STUDENTS IN THE HIGHER EDUCATION SYSTEM.....</b>	<b>33</b>
<b>Section 2. MODERN PROBLEMS OF PHILOLOGY AND LINGUISTICS.....</b>	<b>38</b>
<b>RAKHIMBAEV MUSOBEK KOMILJON O‘G‘LI /// THE LINGUISTIC ASPECT OF DATABASE DESIGN IN CREATING AN ELECTRONIC DICTIONARY OF OGAHI’S WORKS.....</b>	<b>38</b>
<b>SALAEV ULUGBEK /// COMPARATIVE ANALYSIS OF NEURAL NETWORK MODELS FOR UZBEK TEXT CLASSIFICATION.....</b>	<b>43</b>
<b>AKHMEDOVA MEHRINIGOR BAHODIROVNA /// THEORETICAL APPROACHES TO THE CONCEPT OF SEMANTIC FIELD IN UZBEK LINGUISTICS.....</b>	<b>49</b>
<b>QUTLIYEVA MUKHAYO GULOMOVNA /// LEXICAL-SEMANTIC AND GRAMMATICAL STUDY OF ECONOMIC TERMS BORROWED FROM OTHER LANGUAGES.....</b>	<b>53</b>
<b>SABIROVA DILOROM /// UNIQUENESS OF THE FICTION STYLE IN THE NOVEL “OTA” (“FATHER”) BY ULUGBEK HAMDAM.....</b>	<b>58</b>



**Section 3. ACTUAL PROBLEMS IN MODERN ART AND ARCHITECTURE.....63**

**SALAKHIDINOV MASUDDIN SADRIDDINOVICH /// SCIENTIFIC THEORETICAL ASPECTS OF STUDYING THE DEVELOPMENT OF INDUSTRIAL AND INTERIOR DESIGN.....63**

**YUNUSKHODZHAYEVA KHAIRINISA MALLAEVNA, YUNUSKHODZHAYEVA LILUFAR DANİYAROVNA /// CONSTRUCTIVE PARAMETERS OF PRODUCTS IN ERGONOMIC DESIGN OF SPECIAL CLOTHES.....67**

**Section 4. ACTUAL PROBLEMS OF NATURAL SCIENCES.....71**

**DJUMABAYEVA SALOMAT KAMILJANOVNA /// STEPS OF TEACHING STATISTICAL METHODS IN ECONOMIC AND SOCIAL GEOGRAPHY.....71**

**KHALILLAYEV MURAD MUKHAMADSHARIFOVICH, AZIZJANOV KHUSHNUD MAXSUDOVICH, KHASANOV SHODLIK BEKPULATOVICH, KHUDOYBERGANOV OYBEK IKROMOVICH, ABDULLAYEVA ZUBAYDA SHAVKATOVNA /// SYNTHESIS AND CRYSTAL STRUCTURE OF THE Zn (II) ION COMPLEX WITH PARACETAMOL AND GLYCINE.....75**

**SOPORBOEV ZOKIR, ESHCHANOV KHUSHNUDBEK ODILBEKOVICH, DUSHAMOV DILSHOD AZADOVICH /// EVALUATION OF THE REACTION OF UREA WITH O-SUBSTITUTED AROMATIC AMINES USING QUANTUM CHEMICAL CALCULATIONS.....81**

**MAJIDOVA GULNOZA NURMUXAMEDOVNA /// EFFECT OF MAGNETIC FIELD ON VOLT-AMPERE CHARACTERISTICS OF P-N JUNCTION DIODES.....87**

**UKTAMOVA MUNIRA KOMILJON QIZI /// A NEW MODEL FOR CALCULATING THE TOTAL CURRENT IN A TUNNEL DIODE.....94**

**KHIDIRALIYEV KOMIL ESANOVICH, MADRAKHIMOVA ZULFIYA NURMATOVNA /// AGRICULTURE IS A PRIORITY SECTOR OF THE NATIONAL ECONOMY: PROBLEMS AND SOLUTIONS.....100**



## MODERN PROBLEMS OF PEDAGOGY AND PSYCHOLOGY

UDK: 373.211.24

### PRACTICAL ANALYSIS OF THE DEVELOPMENT OF ECONOMIC COMPETENCE OF STUDENTS OF THE PRESCHOOL EDUCATIONAL DIRECTION

**Quchqorova Nargiza Mamajonovna**  
Associate professor of the Department  
“methodology of preschool education”  
Urgench State Department  
[kuchqarova06071979@gmail.com](mailto:kuchqarova06071979@gmail.com)

**Annotatsiya:** Oliy ta’lim talabalariga iqtisod qilishni o’rgatish maktabgacha ta’lim tizimida ham muhim ahamiyatga ega. Ushbu maqolada bo’lajak tarbiyachilarning iqtisodiy kompetentligini rivojlantirishda amaliyotdagi tahlili masalasi o’rganilgan bo’lib bugungi kundagi dolzarb jihatlarini tahlil qilingan.

**Kalit so’zlar:** iqtisodiy tushuncha, iqtisodiy madaniyat, tejamkorlik, moddiy resurs, iqtisodiy muammo, sarf-xarajat, ehtiyoj, daromad, ishbilarmonlik, fan dastur.

**Аннотация:** Обучение студентов высших учебных заведений экономике также важно в системе дошкольного образования. В данной статье рассматривается вопрос анализа будущих педагогов на практике в развитии их экономической компетентности и анализируются актуальные на сегодняшний день аспекты.

**Ключевые слова:** экономическое понятие, экономическая культура, бережливость, материальный ресурс, экономическая проблема, расход, потребность, доход, бизнес, наука программа.

**Abstract:** Teaching economics to higher education students is also important in the preschool education system. This article explores the issue of the analysis of future educators in practice in the development of economic competence, analyzing the relevant aspects of today

**Key words:** economic understanding, economic culture, economy, material resource, economic problem, expenditure, need, income, business, science program.

**Introduction.** Nowadays, great attention is paid to young entrepreneurs by our President. Individuals doing business in all areas are supported. In particular, in the field of preschool education, radical changes are made, opportunities and great benefits are provided to entrepreneurs in order to develop the industry.[1]

Preschool education professionals with higher education, on the other hand, limit themselves to being educators in public MTTs or in private MTTs organized by entrepreneurs from another field. The lack of economic knowledge in them, that is, the inability to carry out business projects, the lack of sufficient skills in obtaining preferential loans from the bank, is considered one of the urgent problematic tasks of the present day.

**Literature review** We talked with students on issues related to the organization of paid services and estimates in state and non-state MTTs in order to determine to what extent the economic competence of future educators is. We also conducted questionnaires on the organization of economy, economic culture and economic

activity. As a result, we found that the formation of economic competence of future educators is an urgent problem today. At the moment, we have set out to find out to what extent the economic concepts of future educators and children in MTTs are. In order for us to further develop knowledge, skills and experiences through the information mentioned above, in order to form the economic competence of future educators who do not have a side of dependence on the system of economics, not enough hours of training given in training programs are allocated. Therefore, it is considered necessary to analyze the processes that shape the economic competence of the educational and educational process together with the student youth and take them into account their opinion. In such cases, various trainings, business Games, discussions, controversial presentations, work in small groups, etc. are mainly used.

In addition to the subject “theory of Economics”, which is defined in the curriculum, electives, additional special courses are organized, which give students the need to introduce such topics as “my business plan”, “concept of sustainable development” within the framework of the specialties they occupy.

The teaching of economics, one of the Social Sciences in higher education institutions, is currently an integral element of the national system of continuing education. The need for Economic Education is determined based on the requirement that republican institutions of Higher Education educate the citizens of the country as competent to correctly assess the economic processes in which they participate.

**Research methodology.** In the current era, the educational system teaches the science of the basics of economic knowledge, but cannot perfectly ensure the development of economic ability in a deep sense, in other words, it does not teach the main task-to avoid mistakes in the adoption of the right solution for young people in important practical situations of life. Students face economic issues every day at home, on the street, as well as through the media (newspaper, television, radio). Information about income, unemployment, inflation, international competitiveness of the national economy, structural changes, conflict between economics and ecology and other issues is an integral part of our daily lives. In their private lives, the aspects of economic activity of student youth will depend on many sides, for example, to carry out their personal budget according to a plan, make payments for family income, personal need, a rational approach to health and lifestyle, make the most of free time, etc. Each student must treat nature, public property with caution and a sense of inviolability, study and understand the socio-economic policy of the state.

Economic knowledge in students, adapted to the basic situation of economic science, its conditions in this environment, it is necessary to provide students with their activities in economic affairs, concepts about the role of Economics in the life of each person. Economic education can be considered as a necessary intellectual resource for understanding the prospect of the development of market relations. Therefore, the main goal of providing economic knowledge is to develop an economic culture that arises in future educators on the basis of a complete adaptation of people to economic conditions by forming an economic thought that meets the requirements of the time, indicates a technique suitable for the economic process, promoting the position of the economy in the process, mastering economic culture and.

Goals aimed at the development of economic abilities - the future also clarify the planned tasks based on the preparation of educators from the economic side to society and life, which in turn consists in the formation of students in a socio-personal way, or rather, spiritual criteria, facing several economic problems in social life and indicating the ways and resources, requirements and proposals that eliminate them. Secondly, the study of moral and spiritual and educational aspects of human professional success, methods of cause and effect of earned, spent money. Thirdly, the formation of a student's Civil position as a citizen of a sovereign state is obliged to influence the solution of many issues, including economic problems, by expressing his opinion.

**Analysis and results.** Nowadays, great attention is paid to young entrepreneurs by our President. Individuals doing business in all areas are supported. In particular, in the field of preschool education, radical changes are made, opportunities and great benefits are provided to entrepreneurs in order to develop the industry. Preschool education professionals with higher education, on the other hand, limit themselves to being educators in public MTTS or in private MTTS organized by entrepreneurs from another field. The lack of economic knowledge in them, that is, the inability to carry out business projects, the lack of sufficient skills in obtaining preferential loans from the bank, is considered one of the urgent problematic tasks of the present day. Students of the preschool educational direction study in The Bachelor's stage at the OSMS for a period of 3 years. In this process, students are prescribed a significant number of specialist subjects (preschool pedagogy, introduction of nature in preschool education, speech and other language teaching in preschool education, organizational culture of the head in preschool education and hakozi) in the educational plan approved by the Ministry of Higher Education. However, no educational subject or elective subject has been recommended for the formation of economic knowledge of preschool students. As a result of this, specialist personnel with higher education who have completed the course of preschool education will not be able to acquire knowledge of the organization of non-state MTTS, the creation of business plans. Therefore, we made an analysis of the science program “preschool pedagogy”, designed for students of the 2nd and 3rd stage preschool educational direction.

Preschool pedagogy. Science Program 2018.

The main theoretical part (lecture sessions).

Module 1 topic 3: the relationship of preschool pedagogy with other subjects

On February 14, 2018, under the chairmanship of the president of the Republic of Uzbekistan Shavkat Mirziyoyev, at a videoselector meeting dedicated to “analysis of the effectiveness of measures taken to radically reform and develop the preschool education system”, says: the next important issue is to expand the network of non-state kindergartens on the basis of Public Private Partnership.

Module 2. Topic 4: factors affecting the development of children of preschool age. Requirements, tasks imposed by our state on the younger generation.

One of the current tasks of Uzbekistan is the quality education of the younger generation. For this, a number of positive and effective works are carried out in the preschool education system. 1 year of compulsory education was also introduced. All this is due to the economic policy of the state.



Topic 5: the main tasks of the Educator of the preschool educational organization and the requirements for his person.

The development of economic competence is considered very important, first of all, for our future educators who are studying in the direction of preschool education. It is necessary that the Educator of a preschool educational organization has knowledge and experience economically, constantly work on the economic upbringing of children in his group, be able to create an environment for them to practice and master in each of their activities, teaching them to save, not spend too much. This is what the current demand dictates. A modern educator must be a person who is mature in all respects and able to meet the demand of the Times.

3-modul. Development of children's abilities in MTT.

Topic 8: the purpose of upbringing is to educate a harmonious personality that has developed in every possible way.

Acquaintance with nature. Science Program 2018.

Basic theoretical part (lecture series)

Module 5. Topic 11 training to give new knowledge, clarify knowledge, strengthen knowledge. Specific principles in the organization of training.

Module 8. Topic 18 development of types of Labor and economic education in the introduction to nature. Teaching to preserve the gifts of nature.

Formation of mathematical representations. Science Program 2018.

Module 2. Topic 4 Organization of work on the development of mathematical imagination in preschool educational organizations.

Module 3. Methodology for the formation of mathematical representations in children of preschool age. Topic 5-formation of their perception of multiplicity, number, calculus, magnitude, geometric shapes. Topic 6 is the use of Game and play exercises, the formation of ideas about quantity, the introduction of the interaction between “many and one”, “many and few” and the division of the whole into elements.

Module 4. Formation of knowledge of number counting in children, teaching to count.

The types of education and training are considered important in the education of educators in MTT as mature individuals. For example, the role of Economic Education and upbringing in the maturation of a child greatly contributes to his plans and goals in the family, in social life and in his future life. Taught to frugality at an early age, the child grows up to be a hardworking, orderly, and up-and-coming business person.

In conclusion, it should be noted that since the most urgent task of today is the development of Economic Education and upbringing in future educators, it is possible to provide economic education and education to future educators not only through the science of “theory of economics”, but through the above-mentioned topics in “preschool pedagogy”. In future educators, it is considered important to develop economic culture in practical, seminar classes and practical classes for students to pass specialist subjects, to give assignments related to financial literacy, the organization of non-state MTTS.

Recognition of National, Historical and cultural traditions, spiritual riches and respect for the culture of other peoples. They are better educated and developed when children respectfully recognize their national culture, language, traditions. The state

curriculum is compiled taking into account national and regional cultural characteristics. Supporting the development of a child in a preschool educational organization is a teamwork, the implementation of which is responsible for the director of the preschool educational organization.

If we instill the above qualities in the educational process in future educators, we will achieve our goals in raising their economic culture in the upbringing and upbringing of the younger generation.

### **Conclusions and recommendations.**

1. Preschool education professionals with higher education, on the other hand, limit themselves to being educators in public MTTs or in private MTTs organized by entrepreneurs from another field. Based on social needs, it serves to clarify the principles of methodological, organizational, management in the process of developing economic competence, effectively solve the development of indicators of economic competence of future educators.
2. Methods for the development of economic competence in future educators: verbal visual, practical and innovative methods; tools for the development of economic competence in future educators: exhibitions, video games, internet sites, smart platforms and mobile applications, etc.
3. The educational plan approved by the Ministry of higher education for the 2019-2020 academic year does not recommend any educational subjects or elective subjects related to the formation of economic knowledge of students of preschool education. As a result of this, specialists with higher education who have completed the course of preschool education will not be able to acquire knowledge on the organization of non-state MTTs, on the formation of business plans. Therefore, when electives are introduced as subjects that direct students to economic activities, the opportunity is created to form the economic competence of future educators.
4. Future educators should also be taught how to explain economic concepts to children in MTTs. Implying to those who are brought up economic knowledge and upbringing, the limitations of the total wealth that exists in nature, the exhaustion of the benefits of nature, but the information about the infinity of human needs from an early age leads them to frugality, the formation of skills for preserving material and spiritual wealth.

### **References.**

- [1]. Law of the Republic of Uzbekistan "on education"-national database of information on legislation, 24.09.2020-y., 03/20/637/1313.
- [2]. Quchqorova N.M. Professional competence and creativity of the educator.-Textbook Tashkent City, Uchtepa district, theme 22, House 17-B. "Bookmany Print", Tashkent-2022., P. 28
- [3]. Carlsson, B and Eliasson, G.,1991 the nature and importance of economic competence.
- [4]. Quchqorova N.M, Nuraddinova R.S. The first step is the organization of thematic activities carried out on the model of the state curriculum.- Tutorial.Tashkent City, Uchtepa District, 22-mauzea, 17-B house. "Bookmany print", Tashkent-2022. P. 42
- [5]. Monkreten Antoine de / / Mirovaya ekonomicheskaya MISL. Squash Prizmo vekov. V 5 t. / Sopred. redcol. Murray T ."Economics is a mess and needs to be reformed", Economics. The next evolution of Economics\journal,





UDC: 376

**PREPARING FUTURE TEACHERS FOR ARTISTIC GAFUR  
ABDURAKHMANOV ANALYSIS OF WORKS OF FINE ART IN SCHOOL**

**Makhkamova Saodat Bakhtiyarovna**  
**Senior teacher of the department**  
**Tashkent state pedagogical**  
**University named after Nizami**  
**[saodatmakhkamova@gmail.com](mailto:saodatmakhkamova@gmail.com)**

**Annotatsiya:** Bo'lajak o'qituvchilarni maktab faoliyatida tasviriy san'at asarlarini badiiy tahlil qilishga tayyorlashning dolzarb masalalari. Maqola "Tasviriy san'at va muhandislik grafikasi" mutaxassisligi bo'yicha talabalar va o'qituvchilarning fan tarkibi bo'yicha bilimlarini oshirishga qaratilgan. Ushbu maqolada tasviriy san'atning chizmachilik va naqqoshlik kabi zamonaviy turlari yoritilgan. Tasviriy san'at darslarini tashkil etish, O'zbekiston xalq artisti G'.M. Abdurahmonova.

**Kalit so'zlar:** portret, avtoportret, uslub, akvarel, kompozitsiya, aromatik, mastika, palitra, rang, janr, vitraj, baget, natyurmort, ranglar, tasvir, element, monumentalist, syujet, refleks, yorug'lik, ritm, soya rassomi, shakl, yorug'lik, chiziq, xarakter, abstraksiya, tekstura, rasm, monumental, byust, statik, plastik, skameykada vertikal va gorizontal rasm, fon, relyef, kontrast, diagonal, grafik, ajoyib, dekorativ, format, dinamika, landschaft.

**Аннотация:** Актуальные вопросы подготовки будущих учителей к художественному анализу произведений изобразительного искусства в школьной деятельности. Статья направлена на совершенствование знаний по предмету состав студентов и преподавателей по специальности «Изобразительное искусство и инженерная графика». В данной статье освещаются такие актуальные виды изобразительного искусства, как рисунок и живопись. Даются ценные научно-методические рекомендации по организации занятий изобразительным искусством и приобретению навыков исполнения композиций с произведениями искусства народного художника Узбекистана Г.М. Абдурахманова.

**Ключевые слова:** портрет, автопортрет, стиль, акварель, композиция, ароматика, мастика, палитра, цвет, жанр, гармошка, витраж, багет, натюрморт, насыщенные краски, образ, стихия, монументалист, сюжет, рефлекс, свет, ритм, теневой художник, форма, свет, линия, персонаж, абстракция, текстура, живопись, монументальный, бюст, статичность, пластика, вертикальная и горизонтальная живопись на скамейке, фон, рельеф, контраст, диагональ, графика, великолепный, декоративный, формат, динамика, пейзаж.

**Abstract:** Actual questions of Preparing future teachers for artistic analysis of works of fine art in school activity. The article is aimed at improving knowledge on the subject Composition of students and teachers in the specialty "Visual Arts and Engineering Graphics". This article highlights such relevant forms of visual art as drawing and painting. Valuable scientific and methodological recommendations are given for the organization of lessons in fine art and the acquisition of skills in

performing compositions with works of art by the national artist of Uzbekistan G. M. Abdurakhmanov

**Keywords:** portrait, self-portrait, style, watercolor, composition, aromatics, mastic, palette, color, genre, harmonica, stained glass, baguette, still life, saturated paint, image, element, monumentalism, plot, reflex, light, rhythm, shadow artist, shape, light, line, character, abstract, texture, painting, monumental, bust, static, plastic, vertical and horizontal painting on a bench, background, relief, contrast, diagonal, graphics, magnificent, decorative, format, dynamics, landscape.

**Introduction.** Ensuring the quality of pedagogical activity, the formation of competence for the analysis of a work of fine art, namely a future teacher, the development of technologies for implementing this in the course of the educational process is the most important task in the field of modernization of the content of pedagogical activity. The Strategy of Actions for the Further Development of the Republic of Uzbekistan is defined as a priority task of improving the system of continuing education. Systemic reforms carried out in the country during the years of independence in the field of culture and art are of particular importance. In particular, a number of significant works were carried out related to the restoration of the ancient heritage, the study of the historical traditions of art, as well as the introduction of modern technology. More importantly, this work is being carried out on the initiative of the President of the Republic of Uzbekistan Shavkat Mirziyoyev. The head of state, emphasizing the importance of this work, created over many centuries by our ancestors, noted “The restoration of the priceless spiritual and cultural heritage created by our ancestors over the course of many centuries has become a very important task for the state. We must begin recovery by developing the growth of national identity as a natural process of returning to our roots and the spiritual origins of our great people“.

Systemic reforms carried out in the country during the years of independence in the field of culture and art are of particular importance. In particular, a number of significant works were carried out related to the renewal of the ancient heritage, the study of the historical traditions of art, as well as the introduction of modern technology. Uzbekistan has become a center for organizing art exhibitions of our domestic artists and craftsmen, as well as foreign professional artists and artisans.

In fact, today, a deep study of the art of science and education, as well as the artistic and aesthetic perception of events around the world based on works of art created by our ancestors over the centuries, is the basis for the development of cultural, artistic and aesthetic culture among young people and together with the positive qualities of the younger generation. In this regard, in art education, improving the content, methods and effectiveness of teaching fine art, in particular painting, drawing and composition, is one of the most pressing problems of pedagogy.

In such an important matter, we hope and rely on the advice and active assistance of all our citizens, especially representatives of the older generation, our wise lives and vast experience of veterans. Thanks to their dedicated work, large industrial complexes were built and modernized in our country in due time. Their intellectual potential and efforts organized new industries based on high technology, built unique infrastructure, formed a farmer's movement, and radically transformed the look of our cities and villages. Thanks to the great love and devotion to the homeland of such people, the

solid foundations of our independent state were created. Taking this opportunity today, let me express my deep respect and sincere wishes for longevity, good health, happiness and prosperity to our esteemed veterans for their selfless work in the name of prosperity of the country. We all know that Uzbekistan has rich Natural Resources, powerful economic and human potential. But still, our greatest wealth is the enormous intellectual and spiritual potential of our people. We well know and appreciate the merits of our intelligentsia - scientists and technicians, especially our esteemed academicians and professors, representatives of culture, literature, art and sports - in creating and enhancing this great potential. Comprehensive support for the scientific research and creative activity of these dedicated people, the creation of the necessary conditions for them should be our first priority. To this end, the Government will develop and implement specific measures.[1].

The interest of artists in the pressing problems of our time, in the implementation of traditions, the expansion of the arsenal of means of artistic expression, characterize landscape painting of Uzbekistan in the 90s. Innovation in the field of shapes and colors, the search for unique expressive means, original artistic manners during the period of Independence was sharp, radical. Contemplation and lyricism, which in the process of developing the landscape of previous eras became one of the priority qualities of the national landscape, did not completely recede into the background, but were transformed into a symbolic, metaphorically saturated form. But all the same, in the period under study, the range of landscape genre works is rather narrow, despite this, many traditions and trends exist and develop in landscape painting. The tendency to enrich the plot material is combined with the enrichment of the emotionally - figurative language, pictorial handwriting. In modern art salons and at special exhibitions, lyrical landscapes and mountain views begin to prevail, the number of chamber landscapes is growing, and artists no longer turn to industrial themes, and a different note appeared in their work, a note of alarm for the future of their planet.

**Literature revue.** As a result of turning to national sources, a figurative-style system of landscape painting of the 90s took shape, in which the following artistic ideas and trends can be distinguished: lyrical landscape - an image of local architectural sights, corners of native nature (N. Kuzybaev, A. Yunusov, A. Mirsagatov , G. Abdurakhmanov, H. Mirzaahmedov, M. Voronov), philosophical and aesthetic, focused on in-depth and innovative comprehension of the foundations of ethnocultural heritage (Zh. Usmanov, F. Akhmadaliev, L. Ibragimov, E. Kambina, H. Ziyakhanov, F. Gamb arova), color-plastic or decorative line (Yu. Chernyshov, R. Akhmedov, R. Shodiev, J. Umarbekov, A. Mirzaev, Yu. Taldykin, E. Melnikov, Ya. Salpinkidi, G. Baimatov, V. Burmakin, I. Shin, R. Gagloeva). Inspirational artists use ornamental and coloristic motifs of traditions. It is characteristic that over time, the division into clear lines between trends becomes more complicated in landscape painting, as the search for an individual creed prevails and the genre specificity is not preserved [2].

The revitalization of artistic life, the organization of major international and national exhibitions, stimulated artists to search for new interesting paintings. Numerous trips of artists in the CIS countries and in foreign countries, contributed to the enrichment of the thematic range of landscape painting.

In the expanding range of searches, contacts with the heritage, attempts to discover artistic ideas in it, the works of A. Mirzaev and artists of a similar decorative orientation (Yu. Chernyshov, R. Shodiev, E. Melnikov, Ya. Salpinkidi, V. Burmakin, R. Gagloeva, V. Kim) characterize important aspects[3].

All this gave rise to bold creative searches, stylistic diversity in the art of Uzbekistan. Among these artists, actively seeking their own figurative language, was Abdurakhmanov Gafur Mukhamedzhanovich. He entered the team of artists of Uzbekistan quickly, attracting the attention of spectators and art lovers with his simple, but immediate landscapes, thematic canvases.

At the beginning of the career of G. M. Abdurakhmanov, he devoted a lot of his energy to the landscape genre. His landscapes often appear at republican and union exhibitions. G. M. Abdurakhmanov is attracted by the snowy mountains of Uzbekistan, its quiet lakes. The wide pastures and cozy foci of shepherds find their artistic expression in the canvases of the artist, he writes willingly and industrial motifs. The picture of the artist "Issyk-Kul" painted under the impression of a trip to Kyrgyzstan attracts silence and special solemnity. The highway, bus parking in the film "Industrial Landscape" bring modern features to the pristine mountain nature. The picture of the artist "Pakhtakor. Match", which attracted attention with its tenderly lyrical construction of the artist to convey the state of nature. Among the artist's landscapes, there are many works that capture the originality and originality of the nature of Uzbekistan, the Caucasus, Russia and the Baltic states. They occupy a large place in the exhibition. In most cases, these works are written soundly, in landscape-genre terms. The second half of the 60s and especially the 70s were fruitful for G. Abdurakhmanov. He actively participates in public life, conducts administrative work at the Republican Art College, where he is appointed director in 1965, becomes a member of the Union of Artists of Uzbekistan, goes on creative business trips, and carries out foreign trips, which positively affects his creative activity. During these years, the artist energetically expands his thematic range, his individual creative manner is increasingly revealed, there is a further crystallization of his ideological and aesthetic position; he works a lot on thematic compositions about the creative work of people, writes industrial landscapes, still lifes. Genre paintings displaying the life and customs of the Uzbek people appear at exhibitions. The audience's attention is drawn to his compositions on historical topics, about the heroism of people.

**Analysis and results.** Paintings "Family", "Wedding" G.M. Abdurakhmanova became landmark. They reflected the artist's search for an individual manner, his ideological and aesthetic views. They outline the search for the creation of an artistic image based on a synthesis of realistic art with techniques and plastically shaped solutions of national miniature painting. When passions subsided, heated debate about the acceptability or unacceptability of the tradition of miniature painting and folk decorative art, we can say that the artist was able to find associative art forms that help him express the pulse and spirit of Uzbekistan. In the painting "Wedding" the individual manner of the artist, outlined in previous paintings, was clearly manifested. The traditions of miniature painting with its high horizon, a lot of plot composition, the rhythm of color spots and planes begin to intertwine with a realistic form of expression. Thematic paintings of the artist are characterized by narrative presentation.

He leisurely narrates about the modern way of life of the people, about the Uzbek wedding in the film “Wedding”, but this does not prevent the artist from conveying his admiration for the beauty of human communications and contacts. Household details in the picture - clothes, furniture, a TV, a bus behind the fence - and others characterize the internationalization of this life, connects it with the modern world. The originality of the artistic approach to the chosen topic is distinguished by the painting “Girls from Bahmal”, which attracts with its figurative-plastic solution, the rhythm of color harmony. Several stylized figures of people of composition, its colorful solution carry a special poetry, hidden spirituality. The painting “Issyk Kul” is permeated with an alarming but majestic spirit, where the silent airships in the sky, the desolation of the valley create a feeling of alarm and at the same time hidden inner power, “Harvest Festival” - a lot of plot composition. In it, an inquisitive viewer has the opportunity to examine in detail each piece of canvas and discover interesting comic and humorous life situations.

Of course, in the aforementioned canvases there is a touch of primitivism, in solving individual images and details one feels toyishness, stylization. But it is precisely in them that the originality, individual identity of the artist, his figurative-plastic thinking and aesthetic creed are sharply felt. All these qualities of the artist’s work put him among the interesting artists of Uzbekistan, who enriches the stylistic diversity of Uzbek art, his picturesque and plastic language with his work. The artist fruitfully combining painting classes with teaching activities in the Order of Friendship of Peoples of Nizami Tashkent State Pedagogical University. He is full of creative ideas, the implementation of which is constantly working, open new aesthetic sensations and feelings.

Creativity of the artist G. Abdurakhmanov is closely connected with the lyrical line of Uzbek landscape painting. His best works are characterized by penetrating lyricism, a concentrated transfer of the state of nature at a certain time of the year and day. He has his own manner of performance, his favorite themes, his attitude to the surrounding reality and his understanding of the means to identify this relationship in a landscape sketch or painting. Quiet streets, deserted surroundings of the city, gardens inspire him. He visits the mountainous region near Tashkent-Humsana. Travel enriches the artist with new themes and plots. For many years, these motifs have become central to his works. The artist’s works created in Humsan are mainly devoted to old-town motifs, environs, valleys and rivers. One of them is “Spring”, which captures a typical Uzbek courtyard of a mountain city. Gafur Abdurakhmanov lovingly depicts the beginning of spring with its cool sunny day. Buds bloom, trees bloom. Juicy greens appear. The picture is closed by Uzbek mountain houses with small and low windows and an open terrace. The large tree in the middle of the landscape, as it were, holds the whole composition, giving it a completely landscape character, the artist managed to convey the spring coolness very clearly and subtly. The harmony of cold and warm tones (cold blue-violet, green tones prevail) gives the painting a special poetry of color. The viewer seems to feel the freshness of a spring day, the game of gentle sun rays and the awakening of nature. The theme of winter is one of G. Abdurakhmanov's favorite topics. he dedicated her many paintings. (Winter Old Town, 1982 Snow fell 1983, winter in Humsan) and a series of sketches and paintings written directly in Humsan.

In its landscapes in front of us there are either noisy streets and bazaars, then quiet Uzbek courtyards or cozy gardens.

Many artists like P.Konchalovsky, I. Mashkov, R. Falk, K. Petrov - Vodkin, Yu. Pimenov, N. Kovinina, R. Akhmedov, M. Nabiev, Y. Salpininkidi, G. Abdurakhmanov, were fascinated by the image of the beautiful world of things. and others created magnificent still lifes, revealing not only the beauty of things, but also the world of man, his thoughts and feelings. Each artist found his expressive means to solve this difficult task. Sometimes a person is invisibly present in the picture, and it seems that he has just left and can return at any moment. Abdurakhmanov's painting in its entirety - the landscape, portrait, still life carries a lively, direct sense of communication with nature. The color in his works is extremely mobile, vividly conveys the state of nature. All the features of the plein air painting are evident with its variable, complex overflow of the finest midtones. However, there is something in his art that allows us to talk about deepening the realistic line in Uzbek painting. This is evidenced by his work: "Still Life with Watermelons", "National Still Life."

**Conclusions.** The inspirational beginning of Abdurakhmanov's creativity has always been nature in all the richness of its manifestations. The themes of his still lifes are natural forms: flowers, fruits, vegetables, a samovar, Susana, fish, everything that carries the living breath of life. He writes them in different settings and each time he discovers a surprisingly whole, optimistic perception of the world. He has a rare gift to extract from the palette such combinations of color shades with which he masterfully conveys the beauty and tenderness of fragile colors, complex lighting conditions. Moreover, the objects shown to them do not lose their material concreteness: drawing, contour, volume.

In the same he writes "Still Life with a Samovar" - a kind of image-representation, inspired by the revolutionary transformations in the country. The artist seeks to find aesthetic value in the objects of industrial society.

In the subsequent development, the still life was significantly replenished with new themes, interesting stylistic features. In it, he reflects the characteristic features of modern life, the achievements of science and technology. The desire to more fully express the theme makes the artist create cycles of paintings.

Still life showed not only the massiveness of the genre, but also the wide coverage of topics. Without breaking the connection with modern reality, the artist turns to the experience of the history of art, carefully examines related genres. Another source is the study of folk art, the study of the experience of previous generations.

The artist refers to still lifes as a means of characterizing the image being created and when working on a portrait. In the subject-thematic paintings, the still life is of important, but still subordinate, importance.

In conclusion, based on the above, we can say that the correct formation and improvement of artistic and creative knowledge, skills and creative skills of students on the basis of the above-mentioned proposals of the content of the article make it possible to achieve effective results in the process of implementing a number of tasks in the process of preparing them for the analysis of works of fine art and topics this will ensure the success of pedagogical competence as a whole. [4]

### References:

- [1]. Sh. M. Mirziyoyev together we will build a free, democratic and prosperous state of Uzbekistan. Speech at the inauguration of the President
- [2]. Of the Republic of Uzbekistan at a joint meeting of the chambers of the Supreme Council Tashkent 2016 "Uzbekistan". Article 39.
- [3]. Tashkent, Nurtoev, S. Makhkamova Issues of preparing students for artistic and creative activity Russia, Kazan Young scientist 2016/7 687 st E-mail: [info@moluch.ru](mailto:info@moluch.ru); <http://www.moluch.ru/>
- [4]. Maxkamova Saodat Baxtiyarovna Podgotovka budushix uchiteley k xudojestvennomu analizu peyzajnogo proizvedeniya v shkole O'zbekiston milliy universiteti xabarlari 1 (4), 115-117 Saodat Maxkamova Baxtiyarovna - Академия Google
- [5]. Saodat Makhkamova Bakhtiyarovna Questions of preparing future teachers for artistic gafur abdurakhmanov analysis of works of fine art in school Euro-Asia Conferences 2021 Информация о статье (google.com)

**UDC: 37.09**

## **TECHNOLOGY OF CREATING ELECTRONIC EDUCATIONAL TOOLS USING MULTIMEDIA TECHNOLOGIES**

**Tillyashaykhova Makhsuda Abdusattarovna**  
**Department of Information Technologies**  
**The Uzbekistan State**  
**Institute of Arts and Culture.**  
[tillyashaykhova@mail.ru](mailto:tillyashaykhova@mail.ru)

**Annotatsiya.** Mavjud o'quv video darslarining turlari ko'rib chiqiladi. Ta'lim sohasidagi animatsiya, modellashtirish, podkastlar va boshqa multimedia texnologiyalari mavzusi taqdim etiladi. Rivojlanish usullari va texnologiyalari o'quv videolarini amalga oshirish uchun dasturiy ta'minot tavsifi bilan ochiladi. Maqola dolzarb multimedia texnologiyalari asosida videoma'ruzalar yaratishga bag'ishlangan. Videoma'ruzalar tushunchalari, ta'lim tizimiga elektron axborot va ta'lim texnologiyalarini joriy etish, informatika fanini o'qitishda Camtasia Studio 8 dasturida videoma'ruzalar yaratish va undan o'quv jarayonida foydalanish masalalari ham tahlil qilindi.

**Kalit so'zlar:** videodarslar, axborot, ta'lim, dasturiy ta'minot, video yaratish, o'qitish usullari, animatsiya, modellashtirish, multimedia texnologiyalari

**Аннотация.** Рассмотрены виды имеющихся обучающих видеоуроков. Изложена тема анимации, моделирования, подкастов и других мультимедийных технологий в образовательной сфере. Раскрыты способы и технологии разработки с описанием программного обеспечения для реализации учебного видео. Статья посвящена созданию видеолекций на основе актуальных в настоящее время мультимедийных технологий. Также были проанализированы концепции видеолекций, внедрение электронных информационно-образовательных технологий в систему образования, создание видеолекций в

программе Camtasia Studio 8 при преподавании информатики и ее использование в образовательном процессе.

**Ключевые слова:** видеоуроки, информация, образование, программное обеспечение, создание видео, методы обучения, анимация, моделирование, мультимедийные технологии.

**Annotation.** The types of available training video lessons are considered. The topic of animation, modeling, podcasts and other multimedia technologies in the educational field is presented. Development methods and technologies are disclosed with a description of software for implementing educational videos. The article is devoted to the creation of video lectures based on currently relevant multimedia technologies. The concepts of video lectures, the introduction of electronic information and educational technologies into the education system, the creation of video lectures in the Camtasia Studio 8 program when teaching computer science and its use in the educational process were also analyzed.

**Key words.** video lessons, information, education, software, video creation, teaching methods, animation, modeling, multimedia technologies.

**Introduction.** One of the main goals of today's education is the introduction of high-quality technologies into the modern education system using electronic resources, increasing the efficiency of education and improving the education system, introducing information and communication technologies into the educational process on a large scale. In recent years, many multimedia software products have been created and are being created: encyclopedias, educational programs, computer presentations, etc. [1]. To implement video training, we use ready-made training video files, but we also create our own films on a specific topic. To create video content, we chose the following programs: Movavi Video Suite, Adobe After Effects CC, Adobe Premiere Pro CC. Successful implementation of video training is based on the right choice of software. Many types of software tools have been created for creating video tutorials, among which CamtasiaStudio8 software is widely used today. These programs are very useful for creating video tutorials on various topics, especially information technology related topics.

What are the capabilities of this software, let's think about it.

Meanwhile, as we observe at the university, currently, when studying disciplines, students experience some difficulties in studying disciplines, this is especially observed among correspondence students. To solve this problem, the university uses modern multimedia technologies, one of the options is the use of video content. Today, learning using video is becoming an increasingly popular way to improve skills in mastering new professions, and most importantly, it provides quick help in resolving many issues in various fields.

What kind of training videos are there? Today, there are a large number of different methods of presenting information and ways to create educational videos [3].

- Filming with a camera. This method requires equipment and shooting skills, this is of great importance, because a modern viewer is not interested in a low-quality picture. The following software is most popular and in demand for video editing: Lightworks, Shotcut, Corel VideoStudio Pro X10, CyberLink PowerDirector 16 Ultra, VEGAS Movie Studio, Adobe Premiere Elements.



- Computer animation. A method that includes vector, raster, fractal and 3D graphics. Requires powerful computer characteristics, a certain set of software and proficiency skills. An animated video in training is a video instruction. Its purpose is to explain how to use, tell about the sequence of actions, and warn against common mistakes. This type of video can be used for any educational purpose, as it is a great way to convey information in an easy and memorable way. Animated 3D videos have a number of advantages:

- the ability to rotate an object and view it from different angles, while the correct shape is not lost on the screen, unlike 2D videos;
- preservation of the principles of perspective, exact dimensions and location;
- approaching reality, preserving the original representation of even complex objects;
- perception of complex nonlinear forms with the help of associations, since in real life we are surrounded by objects in three planes;
- the ability to create new things. The creation of an animated 3D video takes place in several stages: writing a script, modeling objects, creating textures and scans, assigning movement to objects (animation).

Animation is most often created in Autodesk Maya, ZBrush, Blender. Depending on the modeling objects, the following can be used: - Fusion, 3ds Max (architecture, engineering modeling); — ZBrush, Maya, Autodesk Sculpt (people); — AutoCAD, Mathcad (mechanisms, diagrams, microcircuits); — Sap Graphic, Unreal Engine (clothing, style); — Canvas, ShareCad, 3dsMax (art, jewelry), etc. This list also includes educational cartoons, they help to visually examine any task, turn it into a gaming reality, include emotional intelligence, are educational in nature, and create a calm atmosphere. Short cartoons also help to examine in detail the technologies for creating individual objects, with their help you can save time without compromising learning. Another popular type of animation is video infographics. The use of infographics in video makes it possible to present digital information (ratings, financial indicators, graphs, diagrams) in a large volume in a short time, without losing the viewer's interest, facilitating the perception and memorization of the material [5]. By presenting data graphically and comparing one to another, learning information will be much faster and easier. The software for video infographics is: After Effects, VideoScribe, Tawe, Powtoon, Moovly. Adobe After Effects CC is a program for editing video and dynamic images, creating incredible animated graphics and visual effects. The scope of application of Adobe After Effects CC can be very different. This program can be used to process video materials (post-production), create animation (screensavers) for video content, titles, and many other elements that require digital video effects [2].

- Record video from the screen. They help solve your problem well and quickly. The development of such videos can take place in Movavi Video Suite, AVS Video Editor, Movavi Screen Capture, Bandicam, Camtasia Studio, Debut Video Capture, OBS Studio. What are the capabilities of the CamtasiaStudio 8 software, let's think about it. CamtasiaStudio 8 software is very compact and quick to install, does not require additional serial numbers, is distributed free of charge and is one of the small programs. The software has a special function that can be accessed at any time by attaching it to the function buttons. When the program is launched, it will look like

this: The distance education platform <http://uzdsmi.edu.uz> State Institute of Culture and Arts is working. The institute uses the Moodle platform. A video lesson on the technology of creating spreadsheets in the field of art and culture, as well as a video lesson on a practical lesson and a video lesson on a laboratory lesson, was created and posted using the Camtasia Studio 8 program.



Figure 1. Distance education platform



Figure 2. Video lectures created using Camtasia Studio 8 software.

The above analysis of programs designed for creating multimedia teaching aids allowed us to draw the following conclusions [7]:

1. Among the programs we reviewed, Camtasia Studio 8 is by far the most convenient for creating software tools designed to train users in using a collective electronic catalog.
2. Firstly, the program interface is in English and Russian.
3. Since the interface of the Jing, Wink, Webineria programs is English, it will be difficult to master them.
4. Secondly, it outputs AVI, SWF, FLV, MOV, WMV, RM, GIF and CAMV files.
5. You can edit third-party videos.
6. It is also possible to place audiovisual tutorial files recorded by Camtasia Studio in one interface.

The ability to edit video files recorded in Camtasia Studio is very convenient, but the ability to edit video files in Jing, Wink, Webineria is limited.

Movavi Video Suite is a software package with which you can edit an educational film or slide lecture. Movavi Video Suite also includes a set of useful applications, in particular a universal application for recording screen videos and creating video lessons in Movavi Screen Capture Studio. This application captures and records sounds from any part of the computer screen, and saves it in AVI file format, and recently the popular MP4 format used for mobile applications. Finished video clips created in this program can be exported to one of the formats supported by the program - WMV, 3GP, 3G2, AVI, FLV, SWF, MKV, MP4, OGV, MOV, WEBM.

- **Presentations.** An informative way to display videos. If your goal is to show numbers, statistics, screenshots, then this type of video will suit you best. Presentations can be divided into three types: classic - in which information is placed on separate slides, video presentations - data is broadcast in the form of a video, interactive presentations - classic presentations in which the structure and type of presentation of information changes depending on feedback from the audience. Classic presentation software: PowerPoint, OpenOffice Impress, Prezi Classic Desktop, SmartDraw. For video presentations: Wink, ProShow Producer, PromoSHOW, VideoScribe, SlideDog. For interactive presentations: Adobe Presenter, Hippani Animator [5].

- **Video sequence from photos.** A simple and fast way to create videos. Suitable for demonstrating a photographer's portfolio, photo stories, and showing a number of ideas. It refers to photographs alternating with effects. In general, the software for creating this kind of video does not differ from a set for presentations, but there are also specialized ones: PhotoSHOW PRO, Movavi Video Suite, Movavi SLIDESHOW, VideoSHOW, MAGIX Photostory Deluxe, Wondershare DVD Slideshow Builder Deluxe, Windows Live Film Studio.

- **Podcast.** Sometimes, to expand the channels of influence on the audience, podcasts are used not in their standard audio format, but in video format, accompanying the audio with a static picture or text. Such videos also gain a sufficient number of views. Video editing programs will help: Freemake Video Converter, Adobe Premiere Elements.

- **Video case.** Educational videos where professional actors act out a learning situation that is relevant to the topic of the lesson. It describes real circumstances related to the fields of economics, business, sociology, etc. Students thus delve into the essence of the problem, and also come up with their own solutions and choose the best ones. All cases are based on real data or are as close to reality as possible. To create a custom video scribe, you will need to be proficient with a graphics tablet and editing programs (Adobe Photoshop, Adobe Illustrator) when creating the image. At the time of drawing, the screen is recorded; this can be done, for example, using Audacity, Free Cam 8. Then the video is voiced in programs for working with audio (Audacity, Reaper).

**Conclusion.** As practice has shown, the use of video content created using Movavi Video Suite, Adobe After Effects CC, Adobe Premiere Pro CC at our university gives impetus to the formation of critical thinking among students. It was found that with the help of video training, you can visualize an object or process as clearly as possible, create a mood and convey emotions. When visualizing educational material, video helps to synthesize a schematic image of a larger “capacity”, thereby



condensing the information. And students themselves are more willing to use video content in the educational process.

### References.

- [1]. Tillyashaykhova M.A. Innovative Technologies in Pedagogical Education / International Journal on Integrated Education/ <https://journals.researchparks.org/index.php/IJIE>.
- [2]. Stakhovskaya Zh.A. Using video content in the educational process using Movavi Video Suite, Adobe After Effects CC, Adobe Premiere Pro CC. [Electronic resource] <https://cyberleninka.ru/article/n/primenenie-video-kontenta-v-obrazovatelnom-protse> (date of access: 09/08/2023).
- [3]. Ajax and PHP. Development of dynamic web applications / K. Dari [et al.]. - Moscow: Symbol, 2007. - 332 p.
- [4]. Adobe After Effects CC. URL: <https://www.adobe.com/ru> (access date: 09/10/2023).
- [5]. Tillyashaykhova M.A. Theoretical basis of effective application of information and communication technologies in distance education. Tashkent, Fan, 2015, 168 p.
- [6]. Tillyashaykhova M.A. Basics of distance learning T.: "Science"., Tashkent., 2019.- 108 p.
- [7]. Samigova G. A. Multimedia Technologies in the Educational Process of Higher Education/ <https://journals.researchparks.org/index.php/IJIE>.

**UDC: 37.09**

## **ORGANIZING THE METHODOLOGY OF TEACHING THE SCIENCE "ACCESS TO SCIENCE" ON THE BASE OF INNOVATIVE TECHNOLOGIES**

**Zokirov Bahodir Shavkatovich**  
**Navoi State University of Mining and Technology**  
**Senior teacher of the Department of Electric Power,**  
[\*\*zokirovbahodir@gmail.com\*\*](mailto:zokirovbahodir@gmail.com)

**Annotatsiya.** Maqolada oliy ta'lim muassasalari Elektr energetika ta'lim yo'nalishi talabalarini "Yo'nalishga kirish" fanidan tayyorlangan mobil dastur asosida o'qitishda elektron-dasturiy va metodik ta'minoti haqida so'z yuritiladi. Mobil dasturiy vosita mukammal elektron didaktik vosita sifatida xizmat qilishi natijasida talabalarning bilim, malaka va ko'nikmalarining rivojlanish darajasi oshirilishi ilmiy asoslangan.

**Kalit so'zlar:** dasturiy vosita, sinxron, kognitiv, elektron-didaktik, mobil ta'lim, multimedia, interaktivlik, media, innovatsion texnologiya, raqamli ta'lim texnologiyalar, vizual axborot, konsepsiya, E-learning.

**Аннотация.** В статье рассказывается об электронном программно-методическом обеспечении высших учебных заведений при обучении студентов электротехнического направления обучения на основе мобильной программы, подготовленной по предмету «Доступ к науке». В результате использования мобильного программного средства как прекрасного электронного

дидактического средства научно доказано повышение уровня развития знаний, навыков и умений учащихся.

**Ключевые слова:** программный инструмент, синхронный, когнитивный, электронно-дидактический, мобильное обучение, мультимедиа, интерактивность, медиа, инновационная технология, цифровые образовательные технологии, визуальная информация, концепция, электронное обучение.

**Annotation.** The article talks about the electronic software and methodical support of higher educational institutions in teaching the students of the electrical engineering field of study based on the mobile program prepared from the subject "Access to Science". As a result of the mobile software tool serving as an excellent electronic didactic tool, the increase in the level of development of knowledge, skills and abilities of students is scientifically proven.

**Key words:** software tool, synchronous, cognitive, electronic-didactic, mobile education, multimedia, interactivity, media, innovative technology, digital education technologies, visual information, concept, E-learning.

**Introduction.** Innovative e-didactic forms of education take into account the abilities and interests of learners. It is a system of interaction between the teacher and the learner implemented on the basis of general pedagogical, didactic and personal methodological procedures aimed at designing the content of education in accordance with the purpose of education, as well as the implementation of pedagogical and digital technology methods, forms and teaching methods [1].

In general, the educational content should meet the following requirements:

- to be a means of developing students' knowledge;
- to be the basis for the development of students' practical experience;
- formation of critical, independent and creative abilities of students;
- full development of students in accordance with the needs of the level of knowledge they have received.

It is possible to apply electronic educational resources to the educational process depending on the degree of inclusion of educational content, goals and tasks.

**Literature review.** About mobile education, which is developing today, S. Trongtortam, a scientist from Great Britain, gave a generalized definition of mobile education in his scientific works. Mobile learning introduces new learning methods using mobile phones, smartphones, tablets, and portable devices that help students improve their learning styles. Mobile educational technologies are intended to be used to facilitate, support and improve the educational process and teaching, which can be attractive to teachers and students [2].

Mobile learning helps students engage individually in accessible, useful, relevant, and motivating issues to solve systemic problems. In order to adapt to mobile education, teachers working at all stages of education need to master the software tools of modern technologies in order to use mobile education in the educational process. However, we know that there are some problems in this process even in societies with a good socio-economic environment. They include issues such as the lack of educational and methodological support and appropriate guides for teachers, as well as the lack of competence in using mobile learning [3].

In turn, it is necessary to research the requirements and principles of distance, mobile education based on the requirements of today's educational process.

To date, the following principles have been researched by several scholars to create resource content used in innovative educational technologies:

- ✓ principle of multimedia;
- ✓ the principle of continuity;
- ✓ principle of intelligibility;
- ✓ principle of conformity;
- ✓ principle of interactivity;
- ✓ the principle of communication between text and graphic information;
- ✓ the principle of focusing on creating a connection between media elements and cognitive structure.

Relying on the above-mentioned principles, in the preparation of the order of digital education educational material, audio, video, textual data are prepared without leaving the level of normative documents of the science. Based on the ability of students to receive visual information, simple, understandable and accurate information is provided within the topic. In this case, taking into account the continuity of science topics, it is selected according to the interconnection between educational resources [4].

As digital learning technologies are rapidly evolving today, the above principles are self-renewing, and we will try to explore these changes as well.

Based on the above-mentioned principles of foreign scientists, we need to show that mobile education is based on the following principles:

- ❖ it is shown that the use of various methods of information presentation can help to reflect complex processes and events in real life in an unimaginable way;
- ❖ a format associated with a single concept element should be located in a single interface as much as possible. This allows the user to study the object (process, event) from different angles and different methods of manifestation;
- ❖ information such as audio, graphics and text should be used in an ordered synchronous form. This makes it possible not to work with an overload of the user's perception, and also contributes to the multifaceted perception of the object (process, event);
- ❖ the form of the mobile educational material should be appropriate in relation to the educational content and the purpose of the curriculum;
- ❖ it is necessary to take into account the pedagogical and psychological approach to the simultaneous use of textual, visual and audio presentation forms for mobile educational material;
- ❖ complex concepts and processes are presented through a single medium and then presented through two or more information-presenting media;
- ❖ it is necessary to take into account the knowledge and cognitive characteristics of students;
- ❖ students with high level of metacognitive skills should be able to easily find links and any information through hypertext [5].

**Analysis and Results.** Future specialists will acquire knowledge in the development of digital technology in theoretical training, skills in practical training,



and competences in the process of independent education and practical activity. Therefore, practical training and independent education are of particular importance in the development of digital technology. Practical training is one of the important forms of the educational process, students perform a set of educational tasks under the guidance of the teacher. The goal of practical training is achieved by students mastering the scientific and technical basis of training in a practical process. They will acquire knowledge, skills and competences in performing practical work, and with the help of digital educational technologies, they will perform practical work and obtain results through modern methods. When giving theoretical concepts, the teacher first mentions only the purpose of the task in the introductory instructions, and then explains the requirements for its completion step by step. Students can independently learn the sequence of tasks and the methods of its implementation based on practical instructions. Through this, we can observe whether the work is being done correctly, as a result of how much the students understand.

Mobile learning helps students engage individually in accessible, useful, relevant, and motivating issues to solve systemic problems. In order to adapt to mobile education, teachers working at all stages of education need to master the software tools of modern technologies in order to use mobile education in the educational process. However, we know that there are some problems in this process even in societies with a good socio-economic environment. They include issues such as the lack of educational and methodological support and appropriate manuals for teachers, as well as the lack of competence in using mobile education.

Pedagogical experiences from the principles of this mobile education show that the use of digital technologies in the teaching of general professional subjects of "Electric Power" in higher educational institutions is of significant importance in increasing the effectiveness of education. Mobile learning tools play a particularly important role in this [6].

It is important to develop the software for the subject "Access to Science" in the block of general professional subjects of the curricula of the faculties of 60710600 - Electrical power engineering and 60710500 - Energy engineering of higher educational institutions and to further improve the quality of training teachers for innovative professional activities through it.

When giving theoretical concepts on the subject "Access to Science", the teacher in the introductory instructions only mentions the purpose of the task and explains the requirements for its completion step by step. Based on the developed software, the students will have to learn independently the sequence of tasks and the methods of its implementation, based on practical instructions. The advantage of this method is that, as a result, the teacher has the opportunity to devote special time to students who have not mastered the subject well and give them practical help. The result can be determined in the process of observing whether the students are performing the tasks correctly and how much they understand. Methodological instructions have been developed for the performance of practical training tasks, which include: the purpose of the work, the necessary theoretical information for the performance of the work, requirements for exemplary results, independent practical tasks and test tasks for control.



## **Brief theoretical information about the mobile program of "Access to Science"**

The mobile program of "Access to Science" was developed using the innovative technology of "E-learning". The innovative technology of "E-learning" combines distance education with traditional education. This mobile application allows students, as well as independent learners of science, to further strengthen the education given in the classroom, facilitate self-study, self-rating, using personal mobile phones or smartphones at the user's convenience, making it possible to increase the mastery result to 85-90%

The developed software tools reflect all the content of the subjects, the content of the topics of lectures and practical sessions includes theoretical information for each lecture session, glossary, independent tasks, thematic test bank, solutions of sample examples of practical exercises, videos, virtual slides, bibliography, and author briefs for completing the exercises.

### **Components of the mobile program of the subject "Access to Science".**

When entering the application installed on the mobile phone, the main window of the application will be displayed. The science mobile program "Access to Science" consists of the following contents: mobile application home page, program information, table of contents, lecture sessions, practical exercises, glossary, themed and finished subject test bank, bibliography, author summary information.

The mobile application is fundamentally different from other mobile applications due to its easy installation, comprehensibility, the fact that it contains all the necessary information, the teacher and control tests are structured separately for each topic, and it is designed for all Android devices. In order to improve the possibility of self-study of students and the development of individual work skills, a mobile subject program for the subject "Access to Science" of the block of general professional subjects in the curriculum of specialties in 60710600 - Electrical power engineering and 60710500 - Energy engineering recommended for use by industry experts was developed and put into practice. As a result, in the process of mastering the content of general professional subjects, students are not limited to traditional education, but their knowledge, skills and qualifications are increased to the required level on the basis of software education tools based on digital technologies.

**Conclusion.** It led to an objective evaluation of students in the process of teaching them based on innovative technologies, automatically determining the level of development. It is distinguished by the fact that the indicators and criteria that allow for practical control are selected from the software training tools and used as objective evaluation tools, methodological recommendations are developed and put into practice. Practical skills of students are formed in the process of fully mastering theoretical materials. As a result, the prepared mobile program serves as a perfectly programmed electronic didactic tool for electronic software and methodical support of teaching.

### **References:**

- [1]. Inoyatov U.I, Zamonaviy uzluksiz ta'lim muammolari: innovasiya va istiqbollar. Xalqaro ilmiy konferensiya. 2018 y. -5 b.
- [2]. Trongtortam, Suparawadee. A decision support model for mobile technology enhanced teaching. Diss. Liverpool John Moores University, 2019.104.





- [3]. Irby T.L. Instructor Competencies Needed to Develop Instructional Strategies for Mobile Learning in Fields of Agricultural Education: Diss. – 2014.
- [4]. Martina Brajković. Tools and Methodologies for Developing Interactive Electronic Books. ERASMUS program June 2014. P. 4-34-38.
- [5]. Anapiyaev F. Aniq fanlarni o‘qitishda interfaol o‘qitish metodlari // Ma’ruza matni. T-2011. URL: <https://matematika.uz/2017/03/interfaol- metodlar/>
- [6]. Qurbonov G‘.G‘. Umumkasbiy fanlarni raqamli ta’lim texnologiyalari asosida o‘qitish metodikasini takomillashtirish (Axborot tizimlarining matematik va dasuriy ta’minoti misolida). Pedagogika fanlari bo‘yicha falsafa doktori (PhD). Diss. –T.-155 b.

**UDK:378.016:811.111**

## **INTERNATIONALIZATION OF CURRICULUM IN FORMATION OF INTERCULTURAL COMPETENCE OF ENGINEERING STUDENTS**

**Isroilova Dildora Mukhtorovna**  
**DSc, Associated professor**  
**Andijan state pedagogical institute**  
[\*\*dilquv@gmail.com\*\*](mailto:dilquv@gmail.com)

**Annotatsiya:** Maqolada amaliy ingliz tilini o'rgatish jarayonida madaniyatlararo muloqot kompetentsiyani shakllantirish, o'quv jarayonida dasturlarni xalqarolashtirish va fan-til integratsiyasining ahamiyati haqida so'z boradi. Muallif ta'lim jarayonini baynalmilallashtirish muhandislik fakulteti talabalarida kasbiy va xorijiy til kommunikativ kompetensiyasini shakllantirish va rivojlantirishga xizmat qilishini ta'kidlaydi. Muhandislik ta'limini akkreditatsiya qilish bo'yicha Yevropa tarmog'i (ENAE) ta'lim dasturlarini moslashtirish, takomillashtirish va bitiruvchilarni ish bilan ta'minlashga yordam beradigan dasturlari ko'rib chiqildi. Talabalarda xalqaro miqyosida o'zligini anglashda namoyon bo'ladigan tashqi va ichki baynalminallik vosita turlari hamda xorijda ta'lim va mobillik shakllari tahlil qilindi.

**Kalit so'zlar:** madaniyatlararo kompetentsiya, muhandis-talabalar, dasturlarni xalqarolashtirish, fan-til o'zaro integratsiyasi, maxsus kurs, kasbga yo'naltirilgan ingliz tili, qiyosiy, ko'p madaniyatli, transmadaniy, tematik va muammoga yo'naltirilgan.

**Аннотация:** В статье рассматриваются вопросы формирования межкультурной компетенции в процессе обучения практическому английскому языку, важность интернационализации программ и предметно языковая интеграция в образовательном процессе. Автор подчеркивает, что интернационализация учебного процесса способствует формированию и развитию иноязычной профессионально-ориентированной коммуникативной компетенции у студентов-инженеров. Были рассмотрены программы Европейской сети по аккредитации инженерного образования (ENAE) способствующий корректировки, доработки образовательных программ и трудоустройству выпускников. Проанализированы виды интернационализации, такие как внешняя и внутренняя, которые проявляются у студентов в осознании своей роли на международном уровне, а также формы обучения за границей и мобильности.

**Ключевые слова:** межкультурная компетенция, студенты-инженеры, интернационализация программ, предметно языковая интеракция, специальный курс, профессионально ориентированный английский язык, сравнительный, мультикультурный, транскультурный, тематический и проблемно-ориентированный.

**Abstract:** The article discusses the issues of developing intercultural competence in the process of teaching practical English, the importance of internationalization of programs and Content language integration in educational process. The author emphasizes that the internationalization of the educational process contributes to the formation and development of foreign language, professionally oriented communicative competence among engineering students. The programs of the European Network for the Accreditation of Engineering Education (ENAE) were reviewed, facilitating adjustments, refinement of educational programs and employment of graduates. The types of internationalization, such as external and internal, which are manifested in students in understanding their role at the international level, as well as forms of study abroad and mobility are analyzed.

**Key words:** intercultural competence, engineering students, internationalization of programs, Content language interaction, special course, professionally oriented English, comparative, multicultural, transcultural, thematic and problem-oriented.

**Introduction.** The development of international and intercultural skills has been a particular focus over the past two decades because it has contributed to increasing the employability of students. Since the emergence of the concept of competence, the concept of intercultural competence has entered the stages of development of pedagogical science, which shows the ability to function effectively in different cultures, think and act appropriately, and also communicate and work with people from different cultures. Intercultural competence is a valuable aspect in a rapidly evolving world where interactions occur between people from different cultures and countries, shaped by different values, beliefs and experiences. Sergeeva N.N., Pokhodzey G.V. in their works they indicate that “intercultural communication skills are necessary for representatives of different professions. They need to apply knowledge about the culture of native speakers in professionally oriented situations of foreign language speech contact” [Sergeeva N.N., Pokhodzey G.V., 2014; 217].

At the level of higher educational institutions, multilateral interstate relations are being implemented, focused on large targeted and comprehensive educational projects and programs. Currently, students from foreign countries are studying at universities in Uzbekistan in various professional training programs of higher education, and our students are also receiving education in other countries. In the Republic of Uzbekistan, the “2+2” program has been implemented since September 17, 2018, based on document No. 9, which provides for the implementation of mobile exchange of students and double-diploma education. The introduction of such programs increases interest in considering the problems of developing intercultural competence, expressed not only in the processes of cultural integration, but also in the expansion of the information space, business and personal contacts. [Isroilova D. M., 2020;145].

As we know, good command of a foreign language does not guarantee success in an international professional or academic context. Some of the challenges faced by teachers were analyzed from an intercultural perspective. Teaching mobile students in a multilingual and multicultural audience requires the introduction of special programs to develop intercultural competence. According to the Spanish researcher Marta Aguilar, teaching students in the ESP and EMI programs is not enough; it is necessary to introduce the Intercultural Communicative Competence (ICC) program, which could be useful to students and teachers [Marta Aguilar., 2018; 25]. T.B. Frick argues that “the object of study of the theory of intercultural communication is the process of natural communication in natural conditions between representatives of different linguistic cultures, and the subject is the analysis of the types of interaction between representatives of different cultures, the study of factors that have a positive or negative impact on the result of communicative interaction” [T.B. . Frik., 2013;100].

**Materials and methods.** In our interconnected and global world, multilingualism and intercultural skills are becoming increasingly necessary among professionals who need to be able to communicate with culturally diverse people. Currently, European higher education is no exception to this trend, that is, internationalization. According to the Common European Framework of Reference for Language Learning, Teaching, Assessment (CEFR) and Language Proficiency, intercultural skills and knowledge include the following:

- the ability to connect one's own culture and foreign culture with each other;
- cultural sensitivity and the ability to identify and use various strategies for contact with representatives of other cultures;
- the ability to perform the role of a cultural mediator between one's own culture and a foreign culture, to effectively cope with intercultural misunderstandings and conflict situations;
- ability to overcome stereotypical attitudes. [CEFR. 2012;104-105].

As an example, here are some definitions of intercultural competence by these famous scientists: Deardorff, D. K notes “intercultural competence is the ability to develop targeted knowledge, skills and attitudes that lead to visible behavior and communication that are effective and appropriate in intercultural interaction” [Deardorff , D.K., 2006; 241-266]. Milton J. Bennett states, “Intercultural competence is the ability to communicate effectively in intercultural situations and interact appropriately in different cultural contexts” [Milton J. Bennett., 2004;8]. Ting-Toomey S. identifies transcultural communicative competence (TCC), which refers to an integrative theory and practice approach that allows us to consciously apply the intercultural knowledge that we have acquired [Ting-Toomey S., 2007; 29]. In particular, this refers to the process of transformation, connecting intercultural knowledge with proper use in practice. G.T. Makhkamova in her research emphasizes “intercultural competence (IC), which correlates with cultural awareness and cultural sensitivity to “strangers” [Makhkamova G.T., 2019;13-17].

The development of tourism in Uzbekistan reveals development needs - the development of scientific, methodological and practical proposals and recommendations to increase the role of intercultural communications. In this regard,

on December 22, 2020, an international conference was organized at the Silk Road International University of Tourism on modern approaches to the development of intercultural communication. The main goal of the international conference is to create an international platform for the exchange of experience and improve the methodology for the formation of intercultural communication. The famous scientist, I.M. Tukhtasinov, considering the subtleties of the influence of culture on intercultural communication in the training of translators, emphasized that “the creation of a process of intercultural communication is translation, which strengthens relationships, friendship and cooperation between peoples. It also serves the diversity of literature in terms of form, genre and style, improves the content of the language and expands its capabilities” [Tukhtasinov I.M., 2018; 230].

Currently, in the Republic of Uzbekistan, teaching professionally oriented English is considered as one of the most important factors due to the fact that the very training of qualified specialists for various sectors of the national economy urgently requires fundamental changes, and in some cases, completely new teaching methods. In the process of researching the topic under study, we examined analyzes and various approaches to the study of intercultural competence in non-philological universities. The importance and necessity of developing intercultural competence in teaching non-philologist students foreign language professional communication in the process of globalization is emphasized. To do this, it is necessary to use various approaches in pedagogy such as comparative, multicultural, transcultural, thematic and problem-based in teaching language and culture to develop intercultural communication skills that promote motivation in the classroom, and develop a more holistic and comprehensive view of the target and one's own culture.

**Results and discussion.** Currently, in the educational process, when developing intercultural competence, the concept of “internationalization of higher education” is often encountered. According to N.A. Biryukov and N.V. Krasilnikov, the internationalization of higher education is a voluntary process of adopting certain rules and procedures that are recognized and used in the global community, which pays special attention to teachers and students, providing opportunities for acquiring knowledge, skills and competencies in demand in any country [Biryukova N.A., and Krasilnikova N.V., 2019; 448].

The concept of internationalization has certain advantages for development development of an individual university, as well as for the economic, social and cultural development of the country as a whole. The national interests of its participants are realized, a joint search for solutions to problems is carried out, it affects the reputation of the university and improves the quality of higher education. Internationalization of the educational process contributes to the formation and development of foreign language, professionally oriented communicative competence among students. Because programs such as teaching academic writing, preparing for presentations in an international context, writing an application for project funding and intercultural communication programs are directly implemented in the educational process. Currently, in non-philological universities, when teaching special English, CLIL subject language integration technologies are especially popular. A specific feature of subject-language integration of CLIL is that when studying the content of a



non-linguistic discipline in a foreign language, a parallel study of the foreign language itself occurs, which has a positive impact on the success of the internationalization of the educational process. Marsh D. quotes that the introduction of interactive learning should be aimed at increasing the efficiency of the educational process: not from theory to practice, but from the formation of new experience to its theoretical understanding through application in practice [Marsh D., 2002; 552]. When analyzing the educational process and conducting experimental work, conclusions were drawn to integrate the language being studied with the subject “Life Safety and Environmental Engineering” in the formation of intercultural competence and internationalization of programs. Because this discipline presents concepts related to social responsibility in engineering. Safety, environmental protection and sustainability, pro bono work, social justice and diversity are all included in professional codes of ethics related to the social responsibility of the engineering profession. And also integrate with the subject “Production Culture”, which plays a big role in increasing the efficiency of an enterprise. To improve the content of teaching a foreign language (in our case, English) to engineering students, it is necessary to take into account the situations used in the workplace such as: norms of behavior, regulation of a uniform style of clothing, conducting special trainings and organizing joint holidays, as well as other events that help build trust. relationships between people and create confidence among employees in the correctness of the production goals set for them. The famous scientist Shane E. argued that production culture manifests itself at three levels: surface (symbolic), subsurface and deep [Shane E., 2002; 183]. Surface culture includes technology, architecture, communication and behavior. The subsurface culture includes beliefs and values, while the deep culture reveals standards of quality, conduct, and service. When selecting authentic material, we propose to take into account the criteria of production culture adopted in the general standards of engineering activity. Because the right production culture at the enterprise, in turn, brings additional dividends in the form of increased productivity of each individual employee and the profitability of the organization as a whole. Maria Zorayan notes that “in business, the price of intercultural illiteracy can be much higher and can cost the company’s reputation” [Maria Zorayan., 2008;128-134]. Anna Maria Stoica points out that international business professionals need contact with other people. To minimize the “threat”, losses emanating from cultural differences [Anna Maria Stoica., 2009; 72-77].

The International Education Association's Washington Agreement programs include an understanding of the engineer's professional responsibility to public safety. Safety and social responsibility are explicitly included as cognitive “cross-functional” activities within the chemical engineering body of knowledge. The Australian Code, the Royal Academy of Engineering (RAE) Statement of Ethical Principles, uses the term “public benefit” separately from “health and safety”, i.e. “concern for the public welfare”. This means that a high level of foreign language proficiency is insufficient for effective professional, business and socio-cultural communication of a specialist. There is a need for substantive language integration, which will serve to understand the characteristics of intercultural communication, adherence to universal human norms of behavior, rules and categories with certain norms of etiquette in a multicultural world.



Deniko R.V., Shchitova O.G. emphasize that the internationalization of education includes two types: internal and external. Where internal internationalization manifests itself in helping students understand their role in between national level, as well as gain the necessary skills of intercultural communication. External internationalization takes the form of study abroad and mobility [Deniko R.V., Shchitova O.G., 2015; 558-561].

Currently, Uzbekistan is paying attention to reforming curricula and curricula in the learning process. Until 2020, all programs were provided by central universities, but from the 2020-21 academic year there was a decree to develop educational programs independently for each university based on its needs, taking into account the implementation of the system, ensuring the quality of engineering education. Technical universities work together with foreign partners and implement international projects such as QUEECA: Quality of Engineering Education in Central Asia based on the requirements and criteria of ENAEE (European Network for Accreditation of Engineering Education). These works contribute to the creation of the National Society for Engineering Education and the internationalization of curricula, as well as “international recognition, which opens up a number of prospects for future specialists. Ensures the quality of the educational process and the development of domestic science and technology, inextricably linked with production” [Document AIOT-AEET., 2022; 19].

It must be emphasized that this process helps to adjust, refine educational programs and employ graduates. The developed programs based on the criteria (ENAEE) of the European Network for Accreditation of Engineering Education contribute to the formation of global and critical thinking in engineering students, effective communication, both oral and written. For this purpose, we have developed a special program based on the Erasmus+ JP “INTRAS” project in the section “Development of intelligent transport systems in Uzbekistan and organization of master’s programs in this area.” We offered a special course “Engineering Dialogue in English” for first-year engineering students at the master’s level. The purpose of a special course according to the standards is to develop the ability to analyze and interpret engineering issues and problems.

Most higher education institutions in the West are adopting an internationalization strategy for financial gain that encourages cultural differences and tolerance. To solve the problems of globalization, higher education institutions are concentrating on the best the best way to train specialists based on the needs of a globalized society, economy and labor markets. The idea of internationalization views global conditions as local problems that have global consequences. European universities emphasize the need to train the future workforce with sufficient intercultural competencies. Many sources emphasize “the goal of the Bologna Process is “to promote mobility by overcoming obstacles to the effective implementation of free movement.” To do this, it is necessary that the levels of higher education in all countries be as similar as possible, and that the scientific degrees awarded based on the results of training be as transparent and easily comparable” [Bologna process documents., 2022;5]. With this, a new view of internationalization is being formed, and many universities are seeking to cooperate with other foreign educational institutions. This provides the opportunity to study abroad, exchange teachers or staff, scientific

cooperation, and conduct joint trainings. Rokityanskaya K. A. and Mizyurova E. Yu. note that “intercultural competence contains three interdependent components that form a single whole: linguistic, communicative and cultural” [Rokityanskaya K. A., Mizyurova. E. Yu., 2022; 151]. Based on the statements of scientists, it can be concluded that when developing training programs, it is necessary to pay special attention to the content of the subject “Practical English,” which is taught to engineering students at the master’s level.

**Conclusion.** In many scientific sources, pragmalingvodidactics is used to train linguistic students, citing that “specialists must participate in real intercultural communication in various registers of speech communication” [<https://www.livelib.ru/book>]. In our opinion, pragmalingvodidactics is also necessary when teaching students of non-philological fields, because students must master professionally oriented foreign language communicative competence. Consequently, engineering students are entitled not only to the rules of communication, but also to knowledge of the laws of the outside world in general. Because the goal of pragmalingvodidactics, as stated by Akopyants A.M. is “a study of the problems of teaching foreign language communicative competence, allowing students to adequately participate in real intercultural communication depending on the communication situation (formal, neutral and informal)” [Akopyants A.M., 2009;37].

In methodological science, the issue of pragmatization of foreign language training of engineering students is considered. According to Isingalieva Zh.A., Abdirova A.D., Siptanova R.I. “a specialist who recognizes himself as a linguistic personality must be ready to effectively implement foreign language communication and interaction in situations of a professional and everyday nature in an intercultural space” [Isingalieva Zh.A., Abdirova A.D., Siptanova R.I., 2016;50 -52]. Rokityanskaya K. A. and Mizyurova E. Yu. developed a pedagogical model for the formation of intercultural competence by means of a foreign language in the process of professional training of future engineers [Rokityanskaya K. A., Mizyurova E. Yu., 2022; 151-156]. Where, first of all, the social order of society is taken into account, which is divided into a structural and procedural part. In the structural part, scientists consider the goals and objectives of teaching a foreign language, general pedagogical principles and methodological approaches, teaching content, teaching technologies, organizational forms and teaching aids.

In the procedural part, the issue of motivation, foreign language speech activity of students, educational foreign language communication, psychological and pedagogical factors influencing the teaching of a foreign language is raised and, in conclusion, a diagnosis of the educational process is carried out. The analysis of this model once again proved to us the relevance of this research work and the fidelity of the chosen strategy in the formation of intercultural competence of engineering students in foreign language professional communication.

### References.

[1].G.V. Pokhodzey, N.N. Sergeeva (2014) Development of foreign language intercultural competence of students in the system of professionally oriented language education. Monograph. Yekaterinburg - (p3-217).



- [2]. Isroilova D. M. (2020). Professionally oriented teaching of students in English, taking into account interdisciplinary connections in non-philological universities (on the example of the Faculty of Technology). PhD thes. in phil. (p.-145). Tashkent.
- [3]. Marta Aguilar (2018) Integrating intercultural competence in ESP and EMI: from theory to practice. Barcelona, Spain. Journal of ESP Today No. 6 (1) doi:10.18485/esptoday.(p.-25-39).
- [4]. T.B. Frick (2013) Foundations of the theory of intercultural communication. Tomsk Polytechnic University. <https://portal.tpu.ru/departments/kafedra>
5. Michael Byram, (2003) Intercultural competence. University of Durham. Council of Europe press (p-147). <https://rm.coe.int/16806ad2dd>.
6. Kramsch C., (1993) Context and Culture in Language Teaching. Oxford, p- 295. <https://academic.oup.com>.
- [7]. CEFR The Common European Framework of Reference for Languages. [http://www.coe.int/t/dg4/linguistic/Source/Framework\\_EN](http://www.coe.int/t/dg4/linguistic/Source/Framework_EN). (access date 03/12/2020). pdf
- [8]. Dirdof D.K. (2006). Identification and assessment of intercultural competence as a result of internationalization of students. Journal of Studies in International Education no. 1(6), (p-241-266). <https://journals.sagepub.com/home>
- [9]. Milton J. Bennett (2004). The formation of intercultural competence. Portland, Oregon USA, (p. 1-13). [www.intercultural.org](http://www.intercultural.org).
- [10]. Stella Ting-Toomey. (2007). Teaching Intercultural Conflict Resolution: Theoretical and Practical Approaches and Research Problems. California State University. (p-29). Journal of Intercultural Communication Research no. 36(3). doi:10.1080/17475750701737199.
- [11]. Makhkamova G.T. (2019). Reflections on the communicative-cumulative method of teaching a foreign language. Horizhiy philologiya No. 1, Tashkent. (p-13-17).
- [12]. Tukhtasinov I. M. (2018). Development of professional competences on the basis of equivalence occurrence in preparation of translators. DSc diss. in phil. scien. (p.-230). Tashkent.
- [13]. N. A. Biryukova, E. V. Kondratenko, T. V. Kolesova, N. N. Golovina (2019, 4-6 February) Development of students' intercultural competence as a tool of curriculum internationalization. (p.448-452) Proceedings of Intcess 6th International Conference Dubai, U.A.E.
- [14]. Marsh D., (2002) Content and Language Integrated Learning: The European Dimension – Actions, Trends and Foresight Potential. Brussels European Commission. (p.552). American Journal of Educational Research. №3(4), <http://europa.eu.int/comm/education/languages/index.html>
- [15]. Edgar X. Shane (2002) Organizational Culture and Leadership. Moscow-Kharkov-Minsk. study guide. (p-183) [https://ipkpk.ru/documents/the\\_regulations](https://ipkpk.ru/documents/the_regulations)
- [16]. Marina Zoranyan (2008) The Importance of Teaching Intercultural Communication to ESP and BE Students. Georgian Technical University. IBSU Scientific Journal. 2(1), (p 128-134). <https://www.researchgate.net>





UDC: 378.1

## PEDAGOGICAL ASPECTS OF RESEARCHING THE LIFESTYLE OF STUDENTS IN THE HIGHER EDUCATION SYSTEM

Ruziyeva Muhayyo Erkinovna  
Researcher

Urgench State University, Uzbekistan

[Ruzieva\\_m@gmail.com](mailto:Ruzieva_m@gmail.com)

**Annotatsiya:** Ushbu maqolada oliy ta'lim muassasalarida tahsil olayotgan talabalarning salomatligini saqlash, ularda sog'lom turmush tarzi madaniyatini shakllantirish bo'yicha bilim, ko'nikma va odatlarni rivojlantirish, talabalarning sog'lom turmush tarzi va unga bo'lgan ehtiyoj haqidagi bilimlarini rivojlantirish, talaba yoshlarda sog'lom turmush tarzining zarur elementi hisoblanuvchi jismoniy harakatni kuchaytirish haqida so'z boradi.

**Kalit so'zlar:** salomatlik, pedagogik mexanizmlar, oliy ta'lim, ilm-fan, jismoniy tarbiya, sport.

**Аннотация:** В данной статье говорится о сохранении здоровья студентов, обучающихся в высших учебных заведениях, развитии знаний, умений и навыков, связанных с формированием у них культуры здорового образа жизни, здоровом образе жизни студентов, развитии знаний о потребностях студентов, повышении физической активности, которая считается необходимым элементом здорового образа жизни.

**Ключевые слова:** здоровье, педагогические механизмы, высшее образование, наука, физическое воспитание, спорт.

**Abstract:** This article talks about maintaining the health of students studying in higher education institutions, developing knowledge, skills and habits related to the formation of a culture of healthy lifestyle in them, healthy lifestyle of students, developing knowledge about the needs of students, increasing physical activity, which is considered a necessary element of a healthy lifestyle.

**Key words:** health, pedagogical mechanisms, higher education, science, physical education, sport.

**Introduction.** The state's attention to the development of science, education, health care, physical education and sports in our country is increasing year by year. Olympic sports complexes, schools, state-of-the-art hospitals, diagnostic centers, ambulatory polyclinic institutions, and maternity wards were built and commissioned in all major cities and districts of our country during the years of independence. The basic part of old-age pensions and the amount of sickness allowances are being increased. All this has a positive effect on the demographic situation of the population. Now, 14-29-year-olds make up 32% of the population of our country.

Our youth used to go abroad for profit, but now they are returning to the Motherland, due to the implementation of the state policy aimed at solving the problems of youth in our country, the opening of new jobs, and the wider involvement of young people in the economy.

**Literature review.** Although the concept of a healthy lifestyle is more related to the medical direction, our research work requires studying the complex issues related

to the valeological education of students, as well as the medical basis of the problem. For example, thanks to valeological enlightenment, every student knows that more than 200 different cells and tissues in the human body are united into 4 main groups.

Every living being, including humans, is subject to injury and disease throughout life. True, sometimes these are eliminated at the expense of the body's own natural physiological forces, that is, through protective and compensatory reactions. But since this is not always enough, people are constantly looking for new treatments and improving existing ones.

“Health is a great gift for man and society. Only if a person is healthy, he can overcome all the dangers in life and achieve great achievements. A healthy lifestyle is expressed by how a person lives. In particular, it is based on his daily routine, diet and communication with people. In this sense, for the students of general education institutions, the day-to-day should be rationally arranged in accordance with their age (reading, writing, thinking, solving problems, listening and preparing lessons, playing sports), that is, mental and physical labor activities' proper distribution is essential. At the expense of a well-planned agenda, students are prevented from getting tired, have a positive effect on their growth and development, as well as strengthening their immunity and allowing them to fully master all subjects planned in the curriculum of all subjects” [ 1].

**Research methodology** According to J. Montez, the health of students and their level of education are closely related to each other, the health of people with low literacy, those without higher education, and those with higher education, he will be in a much worse situation than that of educated people [2]. According to E.R. Mira and others, the length of the life span is connected with the level of education of a person [4]. According to Ohio University professor K. Ross and Illinois University professor Sh. Wu, the main reason for this is explained by work and economic situation, social and psychological resources, healthy lifestyle [5]. In other literature, the following two factors are considered the main ones:

1. Economic stability [6]. It is known that higher education leads to better and relatively stable and well-paid jobs. This is important for maintaining health and using quality medical procedures.

2. Health behavior [7]. This factor is considered a proximal determinant of health, and health deterioration can be observed as a result of people who do not have a good education working a lot in stressful jobs, tending to burn, sweat, eat unhealthy food and exercise less.

**Analysis and results** The environment that surrounds a person has a significant impact on his mood, educational success and labor productivity, business skills, and labor activity. Therefore, the initial stage of student health protection begins with the creation of an optimal school environment and conditions for students' hard work and health in a higher educational institution. The material basis for creating such conditions in educational institutions is still being formed in the process of designing and building a school building. However, even the best, well-planned, designed, and solidly constructed building cannot provide adequate environmental conditions for the growing organism if the school building is not used properly and its sanitation is not properly controlled.

Unhealthy air environment increases the fatigue of students and causes vegetative disturbances in exercises, therefore, ventilation of classrooms plays a big role in ensuring optimal weather conditions. As a result of research conducted in this field, it was found that students emit 40-60 kcal of heat to the environment in 1 hour.

In closed training rooms, auditoriums with many students (unions, gymnasiums, recreation centers, etc.) during training, the heat released from the body accumulates and the air temperature rises by 2-4<sup>0</sup>C. If the air temperature at the beginning of the exercise is close to the upper limit, it will exceed this limit at the end of the exercise.

Along with the increase in air temperature in the auditorium, water vapors, carbon dioxide, etc. accumulate, including an 8-19-year-old student, in a quiet state, emits about 20 liters of carbon dioxide in 1 hour. Imagine the situation if the number of such students in the audience is more than 30 (50-70 and more in a group)? This condition causes sleepiness, inattention and uncomfortable vegetative changes of students during lectures and seminars. To maintain the sanitary quality of the air in the auditorium until the end of the training, its volume should be changed 4-5 times in 1 hour.

In order to ensure that the air of the classrooms and especially the auditoriums is double-cleaned during each break, it is necessary to open the doors and the windows of the training rooms. All auditoriums should be cleaned with windows open, floors, toilets and doors wiped with 2% chloramine solution or 2% bleached lime.

As a result of the study of the lifestyle of students in the higher education system, it was found that the majority of students do not have an agenda. Daily routine is one of the most important components of a healthy lifestyle. Unfortunately, it should be noted that the respondents who took part in the study did not know how much liquid (water, tea, juice, etc.) they drank, how many kilocalories they ate, how many times and when they should eat, how many kilometers they walked, how much time they spent on homework. It was found that they have a very elementary understanding of when to rest, make good use of free time, etc., in a word, the level of valeological education and healthy lifestyle culture is very low.

As a logical result of the work carried out, the percentage of mastery of all indicators, especially the final result of the educational process, was 15-25% higher in the experimental groups than in the control groups.

Giving priority to technical equipment, computerization, medical-valeological education by improving the teaching process in higher schools creates the basis for the formation of valeological education of students. Therefore, the first step in protecting and preserving the health of students should be the creation of an optimal environment and conditions for the hard work and health of students in higher education institutions.

In the process of development in the country, humanitarian policy, education, health care, science, culture and social spheres, including the priority areas defined as goals, valeological education is the main theoretical and ideological work in preparing a new type of citizen, the main works as a component.

The transition to new forms of events outside the auditorium, increased interaction in social networks affects the feelings and worldview of students, shapes their character and provides a healthy lifestyle, ultimately high citizenship qualities.

completes his upbringing in the spirit of national-spiritual perfection. In this regard, in order to achieve the valeological education of students, it is necessary to pay special attention to wide and systematic teaching and promotion in the directions indicated above, and this process should be under constant control.

**Conclusion.** As a result of the study, the following proposals were developed:

- 1) study of the effect of healthy lifestyle of students on general efficiency and success of training as the basis of valeological education;
- 2) study of ways to improve valeological education;
- 3) effective organization and methodical processing of life activities of students;
- 4) organization of valeological offices in educational institutions;
- 5) new opportunities in the content of the program and educational materials for providing valeological education of students should be explored, and special attention should be paid to making valeological service the main component of national education.

- 6) complex socio-political events that occurred during the period of independence, the fact that more than 20 percent of our homeland was under occupation, the factor of more than one million refugees and internal migrants, the intensification of internal migration related to social problems, the excessive population of the capital. It is necessary to take into account how many difficulties there are in ensuring that the population grows and young people grow up in the spirit of a healthy lifestyle. In this sense, in order to form a valeological worldview of young people, ensure an active life position, especially in order to avoid complications such as illegal trade, production and circulation of drugs, AIDS, alcoholism, Olympic centers, youth homes, stadiums, and valeological services centers should be organized.

- 7) at the current stage, when the country's education system is being rapidly modernized, it is appropriate to turn the medical service in these institutions into a field of medical and valeological service.

- 8) taking into account the formation of the organization of student-youth organizations in higher education institutions, the organization of valeological offices, auditoriums, centers, clubs with their strength, the valeological aspects of multifaceted ideological-social, political and cultural-public events. attention should be paid.

- 9) making good use of the opportunities of the press, mass and electronic media, it is necessary to give priority to forming a valeological worldview in students, turning a healthy lifestyle into a field of daily employment and activity.

#### References:

[1]. Сариккулов М. Х. Ёш авлодни соғлом қилиб тарбиялашда жисмоний соғломлаштиришнинг аҳамияти. Academic research in educational sciences volume 2 | issue 5 | 2021 issn: 2181-1385 Scientific Journal Impact Factor (SJIF) 2021: 5.723. –Б.885.

[2]. Montez JK, Zajacova A. Trends in Mortality Risk by Education Level and Cause of Death Among US White Women From 1986 to 2006. American Journal of Public Health. 2013;103:473–9. [[PMC free article](#)] [[PubMed](#)] [[Google Scholar](#)]

[3]. Zajacova A, Montez JK. Physical Functioning Trends among US Women and Men Age 45–64 by Education Level. Biodemography and Social Biology. 2017;63:21–30. [[PMC free article](#)] [[PubMed](#)] [[Google Scholar](#)]



- [4]. Meara ER, Richards S, Cutler DM. The gap gets bigger: changes in mortality and life expectancy, by education, 1981–2000. *Health Affairs*. 2008;27:350–60. [[PMC free article](#)] [[PubMed](#)] [[Google Scholar](#)]
- [5]. Ross, C. E., & Wu, C. (1995). The Links Between Education and Health. *American Sociological Review*, 60(5), 719–745. <https://doi.org/10.2307/2096319>
- [6]. Mirowsky J, Ross CE. Education, Social Status, and Health. New York: Aldine de Gruyter; 2003. [[Google Scholar](#)]
- [7]. Cutler DM, Lleras-Muney A. Understanding differences in health behaviors by education. *Journal of Health Economics*. 2010;29:1–28. [[PMC free article](#)] [[PubMed](#)] [[Google Scholar](#)]

**UDC: 811.322****THE LINGUISTIC ASPECT OF DATABASE DESIGN IN CREATING AN ELECTRONIC DICTIONARY OF OGABI'S WORKS**

**Rakhimbaev Musobek Komiljon o'g'li**  
**Urgench State University**  
**independent researcher**  
[\*\*musobekgtd@gmail.com\*\*](mailto:musobekgtd@gmail.com)

**Annotatsiya.** Ogahiy asarlaridan foydalanilgan holda asarlardagi so'zlar birlashuvi modeli va ma'lumotlar bazasini qurish bo'yicha ko'rsatmalar majmuasini yaratishdir.

Ogahiy asarlarida qo'llanilgan so'zlar lug'atini elektron shakilda yaratish tamoillari va asosiy masalalari.

**Kalit so'zlari:** o'zbek mumtoz adiblari, mumtoz manbalar, ma'lumot, ma'lumotlar modeli, ma'lumotlar bazasi.

**Аннотация.** Речь идет о создании набора инструкций для построения модели ассоциации слов в произведениях и базы данных с использованием произведений Огахи.

Принципы и основные вопросы создания словаря слов, используемых в произведениях Огахи, в электронном виде.

**Ключевые слова:** Узбекские писатели-классики, классические источники, информация, модель данных, база данных.

**Annotation.** It is to create a set of instructions for the construction of a model of the association of words in the works and a database using Ogahi's works.

Principles and main issues of creating a dictionary of words used in Ogahi's works in electronic form.

**Key words:** Uzbek classic writers, classic sources, information, data model, database.

**Introduction.** In a later period, a number of studies on the language of advertising and legislation appeared in Uzbek linguistics. The subjects "Linguistics and Natural Sciences", "Computer Linguistics", "Mathematical Linguistics" were included (irregularly) in the curricula of philological specialties of higher educational institutions. Some research has appeared in this direction. However, since these studies were among the first experiments in this field, they consisted of providing general information and attempting to apply the existing experience of world linguistics to the Uzbek language.

The created "Electronic Dictionary of Ogahi's Works" will contain at least 20,000 (twenty thousand) keywords. With the help of the mobile application and web applications developed for this model, experience the national heritage of almost a thousand years, created by such geniuses as Yusuf Khos Hajib, Ahmad Yungnaki, Ahmad Yassawi, Alisher Navoi, Zahiriddin Muhammad Babur, Muhammad Reza Ogahi, Mahmudhoja Behbudi, Munavvarkori Abdurashidkhan, there will be ample opportunity to enjoy spiritual masterpieces. In the future, it is important to enrich and improve vocabulary.

**Literature review.** Interest in studying the linguistic analysis of Ogahi's creativity arose in the middle of the last century, when S. Dolimov's article "Linguistic features of Ogahi's creativity" was first published [1]. The article by Z. Dosimov "On the lexical and grammatical features of Ogahi's work "Zubdat ut-tavorikh"[2] talks about the linguistic features of the work. A. Matgaziev identified the morphological features of such works as "Zubdat ul-Tawarikh", "The State of Gulshani", "Shahid ul-Iqbal" [3].

Although the informational, scientific and practical value of Ogahi's works is the same as that of traditional dictionaries, they have advantages in terms of accessibility, potential for attracting a readership and sphere of influence. Therefore, the idea arose of creating 6 dictionaries in the list of thematic topics announced by the Ministry of Innovative Development for 2018-2021 within the framework of state programs related to scientific activities in the direction of "Philology, psychology and pedagogical sciences". previously 3 of them were electronic dictionaries.

- "Electronic Dictionary of Ogahi Works" is compiled in the form of an application intended for lovers of the Uzbek national classical heritage, regardless of specialty, age, nationality, gender, education, citizenship;
- through this application, an Internet resource will be created that will activate the aspirations of people - lovers of the Uzbek national classical heritage, regardless of their specialization, age, nationality, gender, education, citizenship;
- practical suggestions are developed for fields such as philology, education, history, cultural studies, philosophy, ethnography, spirituality, new practical opportunities appear in the activities of republican creative schools in areas such as literary studies, textual studies, comparative analysis, translation studies, hermeneutics (commentary) will be;
- An electronic platform and mobile application "Electronic Dictionary of Ogahi's Works" will be created.

Regarding electronic dictionaries, Nesi "attempted to classify electronic dictionaries and studied the importance of skills associated with the use of electronic dictionaries for second language comprehension [4].

In their studies, Laufer [5], Tono [6], and Wesler and Ritts [7] conducted studies comparing vocabulary use across conditions. Among these, according to Laufer, "incidental vocabulary acquisition is essential for learning in the two reading conditions."

**Analysis and results.** The launch of the application "Electronic Dictionary of Ogahi Works" will provide an opportunity for young people studying at various stages of education to get acquainted with the unique masterpieces of not only Uzbek, but also world culture. This application is in demand in almost all social science specialties in schools, creative schools and universities. The dictionary assumes that visual examples promote universal and national good ideas, and also serve educational purposes.

With the help of this mobile application, information technologies make it possible to solve such processes of education and upbringing as ignorance of our rich national literary heritage, indifference to the creative heritage of classical writers, indifference to the devaluation of the honor of the nation and its main symbol, as well

as some problems that have arisen in social environment can easily show that this can serve as a solution.

The model is applied to words repeated in Ogahi's works. Through the use of these electronic dictionaries, we will be able to learn the meanings of words used in Ogahi's works and in which works they are used.

Let's take one word "*bemisolingg'a*" and look up its meaning and usage from an electronic dictionary.

From the dictionary we know that this word "*bemisolingg'a*" means "*tenggi yo'q husn*".

Use of words in works:

*Chu mazhar aylading olamni husni bemisolingg'a,  
Bu ko'zgu ichra bo'ldi necha naqshi bul'ajab paydo [8].*

**"ALIF" RADIFI.**

The words used in this stanza are very difficult to understand for a student not familiar with ordinary Uzbek linguistics. Therefore, we can find a solution to these issues through a linguistic model, which is built on the basis of in-depth analysis. In the linguistic model, all the words in the stanzas contained in the works of our classic writers are translated into computer language, and for the computer, the space between each word signifies the beginning of another word.

From the process of analysis it is known that the stanzas included in the works of our classic writers are divided into LAWS (words):

*{Chu} {mazhar} {aylading} {olamni} {husni} {bemisolingg'a} {,}  
{Bu} {ko'zgu} {ichra} {bo'ldi} {necha} {naqshi} {bul'ajab} {paydo} {,}*

During tokenization, it turns out that commas and similar delimiters are left in an awkward position for word searches. To avoid this situation, it is advisable to go through each TOKEN and remove unnecessary characters [9].

Now we will comment on the question of what situations we encounter in the process of removing unnecessary characters from tokens and what this changes.

If a number of words used in works and Uzbek linguistics do not have any independent meaning in a sentence, then this feature is included in the list of features that are removed for us. For example, "," is a comma, this character is a separator in the byte structure, so when divided into tokens, this character has no meaning. Several similar conjunctions and grammatical symbols are also excluded from the list of tokens when converting words into computer language.

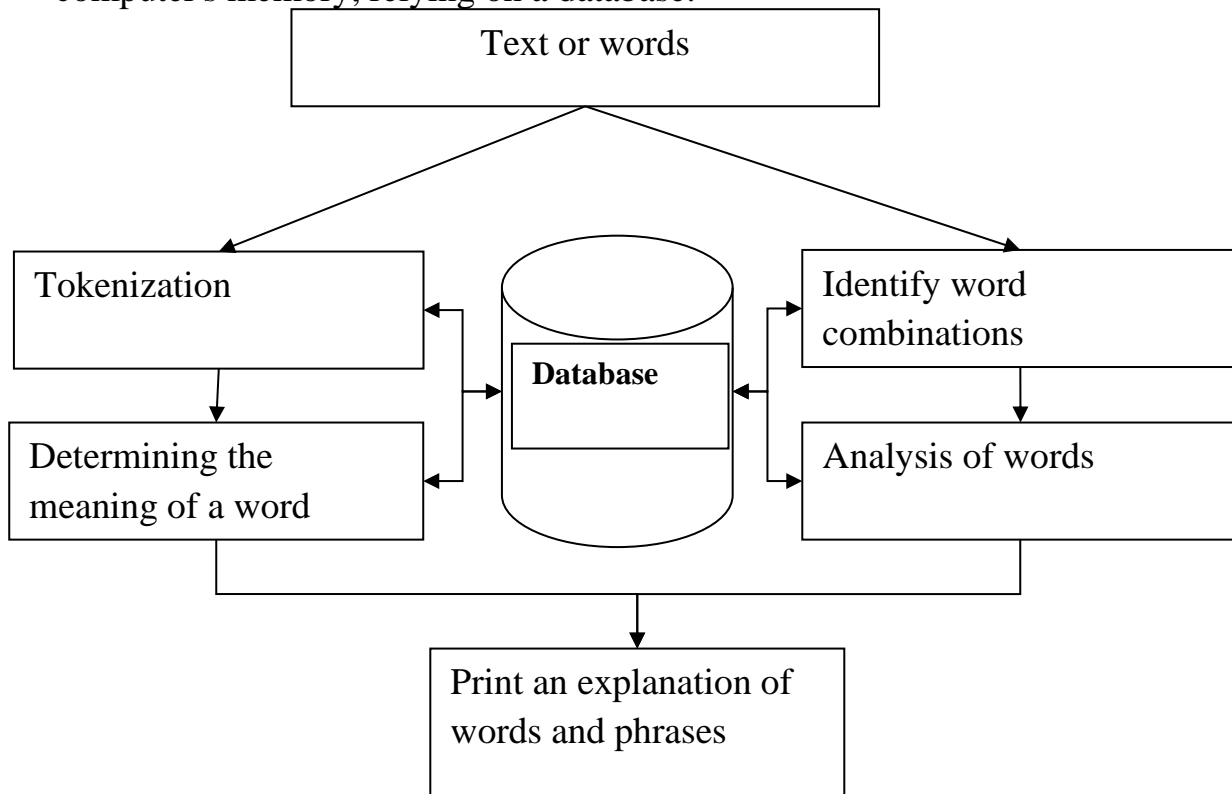
We will remove the unnecessary tokens from our byte above and the result will be something like this:

*{Chu} {mazhar} {aylading} {olamni} {husni} {bemisolingg'a}  
{Bu} {ko'zgu} {ichra} {bo'ldi} {necha} {naqshi} {bul'ajab} {paydo}*

Based on the model created to form the data analysis process, we will create a database model as follows. Using the created circuit, the sequence is executed in the



computer's memory, relying on a database.



On the basis of the block scheme created with the help of deep reasoning, we will be able to algorithmize the sequence of words, texts, bytes.

*The working principle of the model is as follows:*

The above model is completely database driven. In the process of analyzing the words or stanzas entered by the student, he can report the meaning of each word and how it is used in which work.

Example: if we analyze the word “*bemisolingg‘a*” through the model:

The meaning of the word is “*tenggi yo‘q husn*”.

Word usage:

*Chu mazhar aylading olamni husni bemisolingg‘a,  
Bu ko‘zgu ichra bo‘ldi necha naqshi bul‘ajab paydo.*

“ALIF” RADIFI.

This model can provide the student with enough meaningful information during the analysis process.

Let's consider the advantages of the model:

- fast search engine;
- principles of mental influence;
- principle of word analysis;

can provide achievements such as:

Analyzing data based on the above model on the platform that forms the basis of a fast search engine is very easy and simple. Therefore, the search engine is one of the main features of the model.

**Conclusion.** In conclusion, an in-depth study of the works of the Uzbek classic writers given above, taking into account their significance in increasing the prestige and enrichment of the Uzbek language, creating various models for their study and



using them in the modern educational environment. It is advisable to carry out systematic work on In our time, this means that there are few electronic databases for the study and research of the Uzbek language. We hope that the model and electronic dictionary that we want to create will be liked by many.

### References

- [1]. Долимов С. Огаҳий роэзиясида омоним ва синоним сўзлар. Ўқитувчилар газетаси. 1957
- [2]. Дўсимов З. Огаҳийнинг “Зубдат ул таворих” асарининг лексик хусусиятлари ҳақида. Огаҳий абадияти. Тошкент. Ўзбекистон. 1999.
- [3]. Матгазиев А. Исследование по морфологии староузбекского языка (конец XVII- до семидесятых годов XIX в). Автореф. Диссер. д-ра филол. наук. Ташкент. 1979
- [4]. Nesi, H. 2000. The Use and Abuse of EFL Dictionaries. How Learners of English as a Foreign Language Read and Interpret Dictionary Entries. *Lexicographica. Series Maior* 98. Tübingen: Max Nie-meyer.
- [5]. Laufer, B. 2000. Electronic Dictionaries and Incidental Vocabulary Acquisition: Does Technology Make a Difference? Heid, U., S. Evert, E. Lehmann and C. Rohrer (Eds.). 2000. Proceedings of the Ninth EURALEX International Congress, EURALEX 2000, Stuttgart, Germany, August 8th–12th, 2000: 849-854. Stuttgart: Institut für Maschinelle Sprachverarbeitung, Universität Stuttgart.
- [6]. Tono, Y. 2000. On the Effects of Different Types of Electronic Dictionary Interfaces on L2 Learners' Reference Behaviour in Productive/Receptive tasks. Heid, U., S. Evert, E. Lehmann and C. Rohrer (Eds.). Proceedings of the Ninth EURALEX International Congress, EURALEX 2000, Stuttgart, Germany, August 8th–12th, 2000: 855-862. Stuttgart: Institut für Maschinelle Sprach-verarbeitung, Universität Stuttgart.
- [7]. Weschler, R. and C. Pitts. 2000. An Experiment Using Electronic Dictionaries with EFL Students. *The Internet TESL Journal* 6(8).
- [8]. Muhammad Rizo Ogahiy “Tavizu-l-oshiqin” devon, -T: “Mumtoz so‘z”, 2014
- [9]. Speech and Language Processing: An Introduction to Natural Language Processing, Computational Linguistics, and Speech Recognition. Dan Jurafsky, James H. Martin. Prentice Hall, 2009



UDC 811.322

**COMPARATIVE ANALYSIS OF NEURAL NETWORK MODELS FOR  
UZBEK TEXT CLASSIFICATION**

**Salaev Ulugbek**  
PhD student at  
Urgench State University  
[ulugbek.salaev@urdu.uz](mailto:ulugbek.salaev@urdu.uz)

**Annotasiya.** Ushbu tadqiqot mashinali o'qitish modeli va neyrotarmoq modellari yordamida o'zbek tilidagi matn tasniflash masalasida taqqoslashni o'rganadi. Ushbu tadqiqotda o'zbek tilidagi matnlarni tasniflash masalasi uchun yaratilgan ma'lumotlar to'plamidan ajratib olingan 11 ta sinfga tegishli matnli ma'lumotlar to'plamidan foydalaniladi. Mashinali o'qitish modeli aniqlik ko'rsatkichi 94% natijani qayd etgan bo'lsa, neyrotarmoq modeli natijasi kichik ustunlik bilan farq qilgan holda aniqlik darajasi 95% qayd qildi. Ushbu tadqiqot matn hujjatlarini tasniflash masalasida model arxitekturasini tanlashning ahamiyati ta'kidlanadi.

**Kalit so'zlar:** Matn tasniflash, o'zbek tili, neyrotarmoq modeli, morfologik tahlil.

**Аннотация.** В этом исследовании исследуется сравнение модели машинного обучения и моделей нейронных сетей в задаче классификации текста на узбекском языке. В данном исследовании используются наборы текстовых данных, принадлежащие к 11 классам, извлеченные из набора данных, созданного для классификации текстов на узбекском языке. Модель машинного обучения достигла точности 94%, а модель нейронной сети — 95% с небольшой разницей. В данном исследовании подчеркивается важность выбора архитектуры модели при классификации текстовых документов.

**Ключевые слова:** Классификация текста, узбекский язык, нейронная сеть, встраивание слов, морфологический анализ.

**Abstract.** This study investigates the comparison of Machine Learning model and Neural Network model in Uzbek language text classification problem. In this study, the dataset aligned into 11 classes which extracted from the project of text classification dataset for Uzbek language. The Machine Learning model gained 94% accuracy, while the Neural Network model achieved slightly better result with an accuracy rate of 95%. This research highlights the significance of model selection in This research highlights the importance of model selection and suggests neural networks' promise for Uzbek NLP tasks.

**Key words:** Text Classification, Uzbek Language, Neural Network, Word Embeddings, Morphological analysis.

**Introduction.** Computational linguistics integrates human natural language modeling through rule-based approaches with statistical, Machine Learning, and Deep Learning models. The digital content in the modern era has underscored the critical importance of effective text classification techniques. Text classification, a

foundational task in Natural Language Processing (NLP), plays a pivotal role in organizing, understanding, and extracting valuable insights from vast volumes of textual data. This task has widespread applications, including sentiment analysis, topic categorization, and spam detection, among others. While text classification has achieved remarkable success in well-resourced languages, it presents unique challenges when applied to languages with limited linguistic resources and data, such as Uzbek. The Uzbek language is characterized by its rich morphology and unique grammatical features. Developing robust text classification models for Uzbek demands tailored approaches that account for its linguistic properties.

Morphological analysis in Uzbek involves the figure out of complicated word structures, encompassing prefixes, suffixes, and root forms. The highly inflectional nature of the language necessitates a nuanced approach to feature extraction and understanding contextual semantics. Neural network models, with their capacity to capture complex patterns and contextual properties, hold the potential to better in this demanding linguistic landscape.

This research focuses to address the challenges of Uzbek text classification by conducting a comparative analysis of Machine Learning (ML) and Neural Network (NN) models. In particular, we explore the capabilities of neural networks in handling the nuances and complexities of the Uzbek language. Our dataset, curated from a previous research project, encompasses text documents categorized into 11 distinct classes, offering a diverse and representative sample of the Uzbek language's textual landscape.

In our comparative study, we evaluate the performance of various NN architectures designed for text classification. These models leverage word embeddings and dense layers to capture the semantic, syntactic, and contextual information embedded within the text. Moreover, we examine the implications of such models in the context of Uzbek. As a point of reference, we also present the results of a Support Vector Machine (SVM) model, a well-established ML technique known for its robustness. The inclusion of SVM allows for a comprehensive comparison of traditional and neural approaches, to identify the potential gains offered by deep learning methods in Uzbek text classification.

This study represents a contribution to the growing body of research aimed at advancing NLP in less-resourced languages. It underscores the significance of tailored approaches for languages like Uzbek and underscores the potential of NN as valuable tools for text classification. The results of our comparative analysis will not only provide insights into the specific challenges of Uzbek but also serve for future computational linguistic researches using deep learning models.

In the field of text classification, numerous studies have been conducted in English, as well as in various other languages, leveraging techniques such as the ngram model and TF-IDF algorithm. In Uzbek has some preliminary work on sentiment analysis in Uzbek has been undertaken, text classification using NN models remains relatively unexplored. The scarcity of research in this domain, coupled with a lack of

automated processing resources for Uzbek, underscores the novelty and significance of our present study.

**Literature review.** Text classification has been fundamental challenge within the domain of NLP and has numerous applications in various domains such as sentiment analysis [1], and categorization of news articles. With the advancement of ML techniques, the performance of text classification has improved dramatically in recent years. In the early days, traditional ML methods such as SVM [2] were used for text classification. However, the growing size of text data and the increased complexity of the tasks led to the development of deep learning methods [3], [4].

In the studies [5], it is focused the task of multi-class text classification for Uzbek-language texts. A dataset was curated by consisting of articles from ten distinct categories sourced from the Uzbek online news platform. For the classification task, six diverse machine learning algorithms was selected such as SVM, Decision Tree Classifier (DTC), Random Forest (RF), Logistic Regression (LR), and Multinomial Naive Bayes (MNB).

Recently, the issue of text classification for Uzbek news text was considered in [6] works, and this work mainly focused deep learning models using word embedding. Also in the work, Logistic Regression with word-level n-grams (unigram and bi-gram bag-of-words models, TF-IDF scores) models have been used for experiments. To assess the effectiveness of the NN models, rule-based models were employed as reference benchmarks. Specifically, it is employed Recurrent Neural Networks (RNN) and Convolutional Neural Networks (CNN). These were employed to investigate how well these models could capture sequence information and the semantic characteristics of the Uzbek text data.

**Methodology.** Since text classification requires a labelled dataset for training and evaluating the models. For our research, we extracted 10K text documents from Uzbek Text Classification Dataset [7], including news articles and press releases. The documents represent a diverse range of categories, such as politics, sports, entertainment, technology, etc. A number of articles obtained from each source are presented in Figure 1. Document Counts by Category. *Figure 1.*

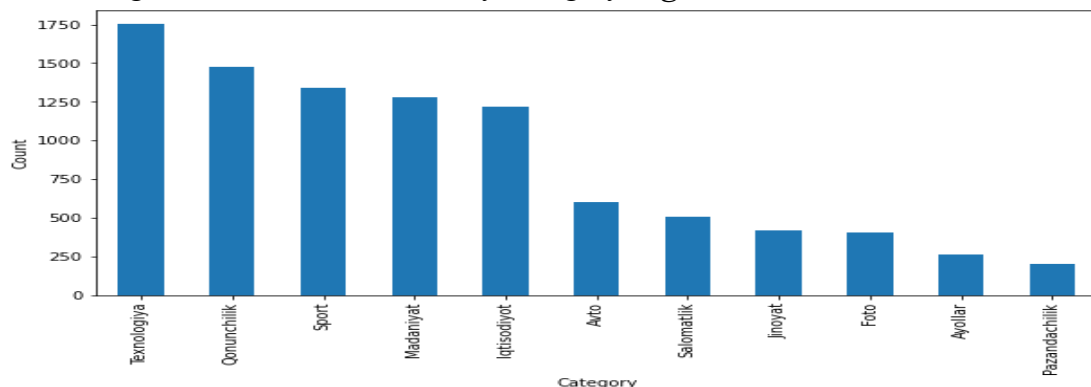


Figure 1. Document Counts by Category.

In this work we employed two distinct models: a traditional ML model–SVM, and the Feedforward Neural Network (FNN) model as Deep Learning model. The

structure of the approach's pipeline include the following outline: (1) get text from dataset and assign its class as label; (2) Case Converting as lower case; (3) Removing stop words from text (list of the stop words are extracted from the work[5]); (4) using TF-IDF Vectorizer for ML model, and TF Keras Tokenizer for NN model training; 5) Testing and evaluating of the models by represents accuracy results and confusion matrixes. An overview of the proposed approach is illustrated in Figure 2. An overview of the proposed model *Figure 2*.

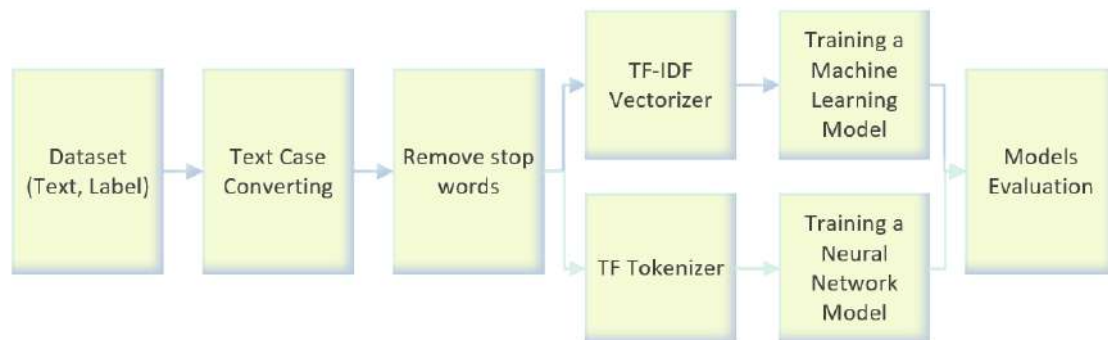


Figure 2. An overview of the proposed model

The primary goal of this model is to classify text documents into predefined categories or labels. It is particularly suitable for binary text classification tasks. A basic Feedforward Neural Network model architecture involved following layers:

*Embedding Layer:* The model starts with an embedding layer, which is responsible for converting discrete word indexes into continuous vector representations. These vectors, known as word embeddings, capture semantic information about words and their relationships. The embedding layer allows the model to understand the contextual meaning of words in the input text.

*Flattening Layer:* Following the embedding layer, there is a flattening layer. This layer reshapes the output from the embedding layer into a one-dimensional vector. It prepares the data for processing by the subsequent dense layers.

*Dense Layers:* One or more dense layers come after the flattening layer. Dense layers are fully connected neural network layers that apply linear transformations followed by non-linear activation functions to the input data. These layers capture complex patterns and dependencies in the text data, enabling the model to learn meaningful representations for classification. The number of dense layers and their units (neurons) can be adjusted to control the model's capacity and complexity.

*Output Layer:* The final layer in the network is the output layer, equipped with a sigmoid activation function. This sigmoid activation function is well-suited for binary classification problems.

After prepare the layers, next stage will be training. The model is trained using a supervised learning approach. It learns from a labeled dataset consisting of text documents paired with their corresponding category labels (1 for positive or class A, 0 for negative or class B). The training process involves iteratively presenting batches of text data to the model, which adjusts its internal parameters (weights and biases) to minimize a loss function. For binary classification, the common loss function is binary

cross-entropy. During training, the model learns to make predictions and update its parameters to improve its predictive accuracy. Training typically involves hyperparameter tuning, including the choice of optimizer, learning rate, batch size, and the number of training epochs.

**Result and Discussion.** We performed a experiments on both models with the proposed dataset. allowing them to predict the categories for each document. The accuracy of our models' predictions was then assessed by comparing them to the ground truth labels of the test dataset, enable to calculate precision, recall, F1-score, and overall accuracy. The models' performance was evaluated through 5-fold cross-validation to ensure robustness and reliability in the results. The accuracy results for both models (SVM and FNN) for each class in the Uzbek Text Classification task are detailed in Table I with F1-score values bolded for the classes that outperformed compared to the model.

Table I. Accuracy results for trained models across classes.

Class	SVM Model			FNN Model		
	Precision	Recall	F1-score	Precision	Recall	F1-score
Avto	0.98	0.8	<b>0.88</b>	0.97	0.78	0.86
Ayollar	0.91	0.89	<b>0.90</b>	0.89	0.88	0.88
Foto	0.98	0.77	<b>0.86</b>	0.98	0.73	0.84
Iqtisodiyot	0.9	0.95	<b>0.93</b>	0.90	0.95	0.92
Jinoyat	0.99	0.97	<b>0.98</b>	0.96	0.95	0.95
Madaniyat	0.94	0.98	<b>0.96</b>	0.93	0.98	0.95
Pazandachilik	0.96	0.9	<b>0.92</b>	0.95	0.85	0.90
Qonunchilik	1.00	0.97	0.98	1.00	0.96	0.98
Salomatlik	0.99	0.96	<b>0.97</b>	0.98	0.94	0.96
Sport	0.99	0.99	0.99	0.99	0.99	0.99
Texnologiya	0.89	0.98	<b>0.93</b>	0.88	0.98	0.92
<b>Accuracy</b>	<b>0.95</b>			0.94		
<b>macro avg</b>	0.96	0.92	<b>0.94</b>	0.95	0.91	0.92
<b>weighted avg</b>	0.95	0.95	<b>0.95</b>	0.94	0.94	0.94

The confusion matrix is a pivotal component of our text classification task, serving as a tabular representation that elucidates the performance of our models across various categories. By examining the confusion matrix, we gain a comprehensive understanding of how our models classify text documents into different categories. In *Figure 3*, presents a visual representation of the confusion matrix of FNN model by the correspondence between the actual class labels and the predicted class labels, enabling us to evaluate the precision, recall, and F1-score for each category.



Figure 3. Confusion Matrix for Feedforward Neural Network Model Predictions.

The basic FNN model for text classification provides a foundational and accessible approach for classifying text data. While it is relatively simple compared to more advanced models like deep transformers, it serves as a strong baseline and can be a valuable tool for a wide range of text classification tasks. Its effectiveness, ease of implementation, and interpretability make it a suitable choice for many practical NLP applications. Researchers and practitioners can build upon this model by incorporating more advanced techniques and architectures to further enhance performance in specific domains.

Furthormore, in this work developed tools based on the trained model:

- To demonstrate the model performance a web interface[1] was created (**Ошибка! Источник ссылки не найден.**);
- The API system[2] was developed with the aim of integrating the trained model into other software;

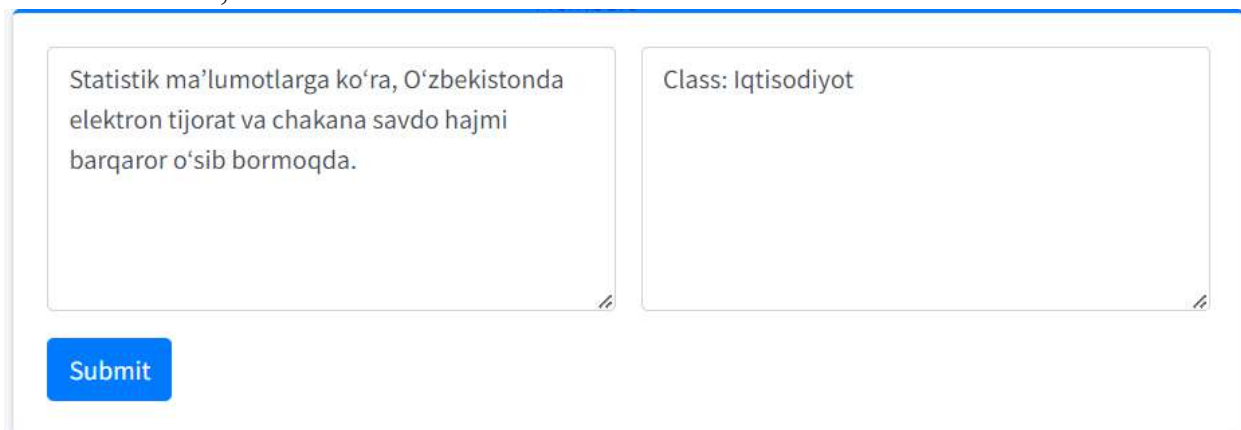


Figure 4. Web interface of Text Classification Model Performance.

**Conclusion.** In conclusion, text classification in the Uzbek language has revealed intriguing insights. In this paper, we extracted part of the existing dataset which consisting of more than 10K labelled news texts with spanned over 11 categories. Our evaluation results showed that the FNN model outperformed SVM models by achieving a slightly higher accuracy rate of 95%. We've shown that deep learning models work well for classifying Uzbek text. In the future, we plan to make these models even better by training them on larger datasets. We also aim to explore other language tasks like morphological and sentiment analyzing.



## References

- [1]. E. Kuriyozov, S. Matlatipov, M. A. Alonso, and C. Gómez-Rodríguez, “Deep Learning vs. Classic Models on a New Uzbek Sentiment Analysis Dataset,” in *Human Language Technologies as a Challenge for Computer Science and Linguistics – 2019*, 2019, p. 258.
- [2] T. Joachims and others, “Transductive inference for text classification using support vector machines,” in *Icml*, 1999, pp. 200–209.
- [3] P. Liu, X. Qiu, and X. Huang, “Recurrent neural network for text classification with multi-task learning,” *arXiv preprint arXiv:1605.05101*, 2016.
- [4] S. Minaee, N. Kalchbrenner, E. Cambria, N. Nikzad, M. Chenaghlu, and J. Gao, “Deep learning–based text classification: a comprehensive review,” *ACM computing surveys (CSUR)*, vol. 54, no. 3, pp. 1–40, 2021.
- [5] I. M. Rabbimov and S. S. Kobilov, “Multi-class text classification of uzbek news articles using machine learning,” in *Journal of Physics: Conference Series*, 2020, p. 12097.
- [6] E. Kuriyozov, U. Salaev, S. Matlatipov, and G. Matlatipov, “Text classification dataset and analysis for Uzbek language,” Feb. 2023, doi: 10.48550/arxiv.2302.14494.
- [7] K. Elmurod, U. Salaev, S. Matlatipov, and G. Matlatipov, “Text classification dataset for Uzbek language,” Feb. 2023, doi: 10.5281/ZENODO.7677431.

**UDC: 811.11**

## **THEORETICAL APPROACHES TO THE CONCEPT OF SEMANTIC FIELD IN UZBEK LINGUISTICS**

**Akhmedova Mehrinigor Bahodirovna**  
**PhD, Associate professor,**  
**English literature and Translation**  
**Department,**  
**Bukhara State University, Uzbekistan**  
[m.b.axmedova@buxdu.uz](mailto:m.b.axmedova@buxdu.uz)

**Annotatsiya.** Ushbu maqolada o‘zbek tilidagi leksikologiyaning semantik sohasi tahlil qilinadi va semantik soha haqidagi nazariyalarning diaxronik va sinxron rivojlanishi muhokama qilinadi. Bu masala ustida ish olib borayotgan turli olimlar semantik sohaning ierarxik, paradigmatic va sintagmatik munosabatlarini tahlil qilib kelishgan. Tezaurus va lug‘atlarga ko‘ra “ma’naviyat”ga tegishli so‘zlar o‘zak (giperonim) va periferiya (giponim) sifatida tahlil qilingan.

**Kalit so‘zlar:** Semantik maydon, leksik semantik guruh, semantik tarmoq, semantik kichik maydon, semantik mikro va makro soha.

**Аннотация.** В данной статье анализируется семантическое поле лексикологии узбекского языка и обсуждается диахроническое и синхронное развитие теорий о семантическом поле. Различные ученые, работающие над этой

проблемой, анализировали иерархические, парадигматические и синтагматические связи семантического поля. По данным тезаурусов и словарей слова, относящиеся к «ma'naviyat», анализировались как ядро (гипероним) и периферия (гипоним).

**Ключевые слова:** Семантическое поле, лексико-семантическая группа, семантическая сеть, семантическое подполе, семантическое микро- и макрополе.

**Abstract.** This article analyzes semantic field of lexicology in Uzbek language and discusses diachronic and synchronic development of theories about semantic field. Various scholars working on this issue have been analyzing ierarchic, paradigmatic and syntagmatic relationships of semantic field. According to thesaurus and dictionaries, the words related to “ma'naviyat” was analysed as core (hyperonym) and periphery (hyponym).

**Key words.** Semantic field, lexical semantic group, semantic net, semantic subfield, semantic micro and macro field.

**Introduction.** Studying the lexicon of the Uzbek language as a semantic field and the fact that it is composed of specific meaningful fields, the internal structure of these meaningful fields, the mutual relationship of units, and the organic connection of fields are one of the issues facing modern linguistics.

The issue of clustering of lexemes on the basis of their lexical meaning, their relationship with each other and with other words has attracted the attention of linguists since time immemorial. For example, Uzbek scientists Prof. H. Ne'matov and R. Rasulov's monograph entitled "Basics of System Lexicology of the Uzbek Language" consistently describe lexeme, nomeme, sememe, lexical meaning, subject groups of lexemes, and content groups of lexemes, scientific definitions are given; attempts were made to reveal the similarity (paradigmatic), step (hierarchical) and sequence (syntagmatic) relationships between language units.

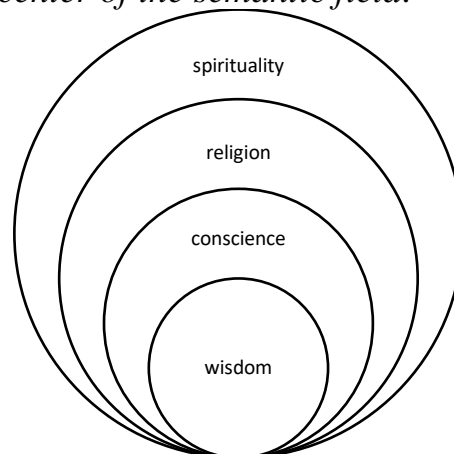
**Literature Review.** H. Ne'matov and R. Rasulov pointed out: "The system is studied as lexical systems in which each field (profession, ritual, tradition, names of people, place names, scientific terms) is named separately. Each field has its own lexemes, synonymous and antonymic lines, MGL (meaningful groups of lexemes), TGL (thematic groups and areas of lexemes). Each of them is considered as a separate, relatively independent system,". According to Prof. E. Begmatov, systematicity in the lexicon is not as obvious as in other levels of the language. Lexical units are much more numerous than phonemes and morphemes and have periodic instability. Therefore, it is not possible to identify and research the lexicon in its entirety. Nevertheless, there are certain methods and methods of scientific classification of the lexical system.

On the basis of what has been said, it can be concluded that the study of the thematic areas of lexemes, meaningful groups and groups of lexemes, and the spiritual relations between them constitutes one of the promising directions of the lexicology of the Uzbek language. It is related to the semantic theory of detailed research of lexical units included in the scope of one topic, determination of their linguistic signs and creation of dictionaries and glossaries for various purposes. Examples of this are the dictionaries dedicated to phrasemes and homonyms by Sh. Rakhmatullayev, synonyms by A. Hojiyev, antonyms by the authors' group, paremiological units by H.

Berdiyeva, R. Rasulov, etc. In these dictionaries, their paradigmatic and syntagmatic features are revealed based on the internal and external relations of lexemes. For example, prof. Sh. Rakhmatullayev made reasonable conclusions about the semantic nature of phrases, internal syntactic construction, paradigmatic forms, syntactic environment and variation. We can say that these, in turn, together with other scientific views served as an impetus for the development of the third direction of systemic structural linguistics. Based on the theory of the semantic field, carrying out separate scientific and research works in different fields began mainly in the 70s and 80s. In this regard, the lexicology of the Uzbek language has moved from the descriptive stage to a new theoretical stage. This stage is characterized by studying the lexicon as a whole system consisting of certain semantic groups, relations of certain meaning elements. In traditional linguistics, the main attention is paid to the main types of relations (homonym, synonym, antonym) on the inside and outside of lexemes, as a result of scientific research in the system-structural direction, hyponymy (gender-species), paronymy of spiritual relations (whole-piece), graduonimia (leveling), hierarchonimia (stepping) are being revealed.

**Analysis.** In Uzbek linguistics, I. Kochkortoyev's word and its semantic valence, Sh. Rakhmatullayev, R. Yunusov, Rano Sayfullayeva's lexeme, semema, semes, R. Rasulov's state verbs, Sh. M. Iskandarov's it is possible to show the microfield of person in nouns, N.R. Nishonova's analysis of the field of lexemes with the "animal" archetype, S. Kh. Muhamedova's semantics of action verbs, H. Tojimatov's work on qualitative semantics, and other scientific studies.

*Sh. Safarov and M. Mirtojdiyev took the semantics and semasiology of the Uzbek language to a new level. As the main issue of semantics, it is necessary to note the phenomena related to the lexical meaning and its development. The semantic field has a special place in the development of computer lexicography. Basing on the theory of the semantic field in the thesaurus of terms makes it possible to quickly and easily master the concepts of the field. [3] For example, the concept of "spirituality" enters into an equal relationship with the following words, united based on the semantic field: enlightenment, ideology, personal improvement. The following terms make up the concept of "spirituality": insight, attitude, conscience, morality, religion. These concepts are located in the center of the semantic field:*



The following models are used in thesauruses: SD – semantic domain, SF – semantic field, SSF – semantic subfield, SM – semantic microfield. When dividing words into semantic fields, it is first approached from the "concept field". According to this approach, each word belongs to a certain "concept group", that is, the semantic field, and none of them remains in the intermediate position. The historical development of the meaning of "z" is interpreted as the re-partitioning of an unchanging field, so the belonging of the word to the semantic field has a synchronic character, and periods can undergo significant changes. It is also noted that the words are not related to each other in the semantic field. The non-adherence of word meanings is a relative concept, and etymological analyzes show that lexemes belonging to different fields can be semantically connected. [4]

**Discussion.** Researching the semantic fields of words in Uzbek linguistics was an unknown and unexplored field until the 80s of the last century. Only by extracting words from a certain semantic field, it was approached in other directions of semasiology. Due to the efforts of linguists, the study of the semantic fields of words on a linguistic basis entered Uzbek linguistics only from the 90s of the 20th century.

If we analyze the opinions about the semantic field by interpreting concepts such as sema, semema, the terms semema and lexical meaning mean the same concept. Semema does not consist of an indivisible unit, but has a structural member. R. Yunusov, Sh. Khojayeva mention this element of lexical meaning as sema. The word in the lexical unit state is used as lexeme, the lexical meaning is semema, the components of the lexical meaning are used as sema. In each national language, lexemes are gathered and clustered in one place based on certain rules. In the course of the unique historical development of the language, these lexical-semantic groups are constantly changing in terms of quality and quantity. [3]

**Conclusion.** Studying language as a field helps to understand the dialectical relationship between the world, consciousness and language on a scientific basis, to create ideographic dictionaries, to fully understand the main collection of lexical combinations used in a certain field by language owners, to use the most necessary of them in the process of communication. in application, it helps to connect lexical compounds with each other in terms of content.

#### References:

- [1]. Begmatov, E. Lexical layers of the modern Uzbek literary language. - Tashkent: Science, 1985.
- [2]. Nematov H, Rasulov, R. Fundamentals of Uzbek language system lexicology. - Tashkent: Teacher, 1995.
- [3]. Iskanderova Sh. Approach to the language system based on the content field. Tashkent: Science. 2007.
- [4]. Kholmanova Z.T. Semantic field and semantic web possibilities. Computer Linguistics: Problems, Solutions, Prospects International Scientific and Practical Conference. Vol. 1 no. 01. 2022. – pp.37-43.
- [5]. Magdalena NGONGO, Akhmedova Mehrinigor. A Systemic Functional Linguistic Analysis of Clauses Relationship in Luke Gospel Text, Janji Baru Using Kupang Malay. Studies in Media and Communication Journal. Vol.11, 2023. - P. 33-40.



- [6]. Fitria Nur Hasanah, Rahmania Sri Untari, Shofiyah Al Idrus, and Akhmedova Mehrinigor Bahodirovna. Excel in Critical and Creative Thinking in Object-Oriented Programming. H. Ku et al. (Eds.): ICARSE 2022, ASSEHR 748, 2023. - P. 301–305.
- [7]. Hazim Hazim, Ratih Puspita Anggraeni, Akhmedova Mehrinigor Bahodirovna. Altruistic Actions in COVID-19 Corpses Care: Empathy, Modeling, and More. International Conference on Advance Research in Social and Economic Science (ICARSE 2022), 2023/4/27. - P.476-484
- [8]. ISLOMOV ELDOR YUSUPOVICH, AHMEDOVA MEHRINIGOR BAHODIROVNA. THE ESSENCE OF SPIRITUALITY IN THE UZBEK LANGUAGE. XIII МЕЖДУНАРОДНАЯ НАУЧНО-ПРАКТИЧЕСКАЯ КОНФЕРЕНЦИЯ " ЯЗЫК И КУЛЬТУРА "Челябинск, 26 апреля 2018 года. - P.12-15
- [9]. Akhmedova Mekhrinigor Bahodirovna. “ANALYSIS AND DIFFERENT INTERPRETATIONS OF THE CONCEPT OF SPIRITUALITY”. Indonesian Journal of Innovation Studies, Vol. 18, May 2022, doi:10.21070/ijins.v18i.590.
- [10]. Akhmedova Mekhrinigor Bakhodirovna. ““SPIRITUALITY” LANGUAGE CATEGORY AND ITS CONTENT”. Middle European Scientific Bulletin, vol. 6, Nov. 2020, pp. 57-59, doi:10.47494/mesb.2020.6.115.

**UDC: 811.1**

## **LEXICAL-SEMANTIC AND GRAMMATICAL STUDY OF ECONOMIC TERMS BORROWED FROM OTHER LANGUAGES**

**Qutliyeva Mukhayo Gulomovna**  
**Teacher of the interfaculty**  
**foreign language department**  
**Bukhara State University**  
[\*\*qutliyevamuhayyo@gmail.com\*\*](mailto:qutliyevamuhayyo@gmail.com)

**Аннотация.** Лексический пласт английского языка, обслуживающий сферу экономических знаний, обширен и разнообразен, поскольку сама экономическая реальность чрезвычайно сложна и противоречива. По данным экономических словарей, он насчитывает около 70 тысяч терминологических единиц.

**Ключевые слова:** экономические знания, экономические словари, терминологические единицы, экономическая лексика, политическая экономия, экономические отношения.

**Abstract** – The lexical layer of the English language, which serves the sphere of economic knowledge, is vast and diverse, since economic reality itself is extremely complex and contradictory. According to economic dictionaries, it has about 70 thousand terminological units.

**Key words:** economic knowledge, economic dictionaries, terminological units, economic vocabulary, political economy, economic relations.

**Introduction.** Economic vocabulary is not a simple mechanical combination of language names. They are in certain cause-and-effect relationships in accordance with the relationships that arise between economic concepts, and form, based on the latter,

aggregates with a characteristic internal structure. In order to determine the initial principles for the analysis of these aggregates in an economic dictionary, to identify the patterns of their formation, and also to isolate those parts of them that are united by systemic relations, and among them - the terminological system of political economy, it is necessary to briefly dwell on the subject of science "political economy"; because the form of the language is not indifferent to the content of the science itself.

**Literature review.** The founders of Marxism-Leninism emphasized the need to distinguish between two groups of relations between people in material production: technical production and social production. Therefore, K. Marx noted, "political economy is not a technology." V. I. Lenin wrote, "political economy is not concerned with "production" at all, but with the social relations of people in production, with the social system of production."

Production (or economic) relations between people are the subject of political economy in the scientific, Marxist-Leninist understanding. In a complexly subordinated system of economic relations, the primacy belongs to the relations of the sphere of the direct production process (primarily the ownership of the means of production), and distribution, exchange and consumption are derivatives. Relations with nature and technical-production relations, as you know, do not constitute the subject of political economy, they serve as an object of study in the natural, technical and concrete economic sciences.

**Analysis.** Bourgeois political economy is distinguished by extreme eclecticism, a subjective-idealistic approach to the definition of its subject matter. In some theories, the subject of political economy is declared to be technological processes, in others - frugality, as the relationship of man to nature. In addition, those theories that declare distribution, exchange or consumption by the object of their study, exclude from it, like all other bourgeois economic theories, the social relations of material production.

The system of production relations, penetrating its cause-and-effect relationships, formed the conceptual apparatus of political economy. Nevertheless, since this science took shape in a class-antagonistic capitalist society and therefore developed as a bourgeois, petty bourgeois and proletarian (Marxist-Leninist) political economy, the vocabulary serving the field of economic knowledge could not be homogeneous. It is a specific set of linguistic units denoting the concepts of each of these three class-defined economic theories.

Consequently, the logical basis on which the lexical means of the language of science are grouped in the sublanguage of political economy was fixed primarily in the differentiation of the corresponding vocabulary of the English language into two radically separate terminological systems. Within each of them, there is its own structure of lexical layers, which is characterized by the combination of non-terminological vocabulary (external layer) with terminological vocabulary (within which the core consisting of basic or categorical terms should be highlighted).

The specificity of bourgeois economic vocabulary lies in its heterogeneity, namely, in the multitude of terminological systems that form it, generated by the existence of various eclectic schools and directions of bourgeois economic thought. Some of these term systems correlate with each other as basic and derivative, others intersect, a significant part of them are not outwardly interconnected. The same

relationships characterize the cores of these term systems, and their share in each term system is relatively small.

Tracing the specifics of these lexical sets, emphasizing the predominance of the features that distinguish them from each other, at the same time, it is necessary to dwell on some features common to them. Therefore, the language units included in the non-terminological vocabulary are largely common; these are official and some full-valued words. The former include unions, allied adverbs, modal words that serve as means of communication between elements of an economic text. Significant words denote technical, technological, organizational, economic, monetary, financial, and other concepts, as well as everyday concepts involved in political and economic analysis: area (район, площадь), girmnik (рекламный прием), judge (арбитр, эксперт), key (шифр, код), lapse (промах, ошибка), list (список), member (член), number (число, показатель), sort (вид, сорт), vehicle (автотранспортное средство) and etc.

In the terminological vocabulary of both lexical sets, the following are also similar: some general scientific concepts: abstraction (абстракция), analysis (анализ), division (разделение), form (форма), method (метод), movement (движение), quality (качество), quantity (количество), structure (структура), system (система) and etc.; a limited number of special political economy concepts, including the main ones (but the similarity here is mainly only in terms of expression): accumulation (накопление), bank (банк), capital (капитал), commodity (товар), labour (труд), market (рынок), money (деньги), production (производство) and etc.

Differences in the lexical means of Marxist-Leninist and bourgeois political economy exist both in the sign expression of concepts and in terms of the content of terms. This is most clearly seen when the terms are not considered in isolation, but in a number of other terms linked through a definition.

Thus, each of the term systems includes the term economic cycle (economic cycle), the content of the concept denoted by this term is revealed most fully through the definitions of the terms of the phases of the cycle. In Marxist political economy, this is a crisis (кризис), depression (депрессия), recovery (оживление), boom (подъем); in the bourgeois - contraction (сжатие), revival (оживление), expansion (экспансия), peak (подъем).

**Discussion.** In official documents in the United States (for example, the National Bureau of Economic Research), terminological confusion is allowed. Therefore, instead of the term contraction, the term recession (recession) is often used and at the same time, it sometimes replaces the term peak.

Differences in terminology between Marxist-Leninist and bourgeois political economies relate primarily to terminological fields.

The main macro-field in the terminological system of Marxist-Leninist political economy is the "System of production relations", which includes the following micro-fields: "Relations in the direct process of production", "Relations of distribution", "Relations of exchange", "Relations of consumption". Each of these microfields has its own specific internal structure, which is formed by smaller conceptual groups included in them, and individual concepts. So, for example, the microfield "Relations in the direct process of production" covers "Relations of ownership of the means of

production", "The position of classes and social groups in production and the exchange of activities between them."

In the terminological system of bourgeois political economy, the main macro-field is "Distribution and exchange", which in turn consists of many micro-fields, small conceptual formations and separate concepts, the boundaries between which are often blurred, fuzzy.

So, for example, "Value", "Demand and supply", "Marginal utility", "Abstention", "Economic entity", "Psychological properties and inclinations of the subject", "Eternal laws", etc.

The theoretical analysis of the term systems of the English language, their place in the structure of the English economic vocabulary, must be supplemented by a special consideration of the important issue of classifying terms according to their value status (i.e., according to their place in the hierarchy of linguistic conceptual means) and, on this basis, the selection of units in basic lists of terms of Marxist-Leninist and bourgeois political economy.

The main list of terms allows us to single out from their total mass those units that denote concepts that make up the conceptual core of science and carry the greatest semantic load. Relying on the conceptual principle of terminology analysis at the forefront put forward the semantic criterion for selecting terms in the main list (formal criteria play a subordinate role here).

In science, several different classifications of concepts are used: in terms of their content, real existence and the number of objects covered by these concepts, as well as the relationships that are established between these concepts, etc. In our study, we took the classification of concepts according to their content as a starting point. On this basis, concepts differ from each other as basic (initial, key), derivative and complex (built on the basis of the main ones); basic, i.e. borrowed from other sciences underlying this one; attracted (concepts borrowed by this science from related fields of knowledge). The terms denoting these concepts are classified in a similar way: among them, there are basic, derivative and complex, basic and involved.

If we abstract from formal features, scientific terms can be combined into two broader classes: the class of theoretical (categorical) terms and the class of empirical (non-categorical) terms.

The formation of the main lists of terms should be carried out separately for each political economy terminological system. When compiling the main lists, it must be taken into account that the conceptual and formal classification of terms do not always coincide. According to formal features, terms are divided into simple, derivative and compound words, as well as phrases. Most of the main terms are simple words, but many terms - simple words also denote peripheral concepts of the term system. Derived terms can be both derived words and compound words and phrases.

At the same time, some terms derived from the formal classification can be included in the main list of terms because, in the course of the development of scientific knowledge, the concepts they denote become the main ones. The criterion of a terminological phrase is the integrity of its meaning. When compiling the main lists of terms, we used the methodology proposed by T.G. Sokolova in the study "Terminology of Marxist-Leninist Philosophy in English".



The main list of terms of the Marxist-Leninist political economy of capitalism in English was formed by us on the basis of 18 samples from the works of the founders of Marxism-Leninism, written by the authors in English, and translations of their works into English, while a continuous painting of the report of K. Marx was carried out "Wages, Price and Profit", as well as original works of the Marxists of Great Britain and the USA.

The main list of terms of bourgeois political economy was compiled on the basis of the materials of the continuous painting of the book by J. Keynes "The End of Laisser-Faire", selections from the works of Anglo-American economists, representing the main directions of modern bourgeois political economy. Lexicographic publications were widely used.

The specificity of the method of studying economic terminology is manifested primarily in the leading role of comparative analysis of the two term systems of political economy in the English language, both in terms of the formation and functioning of their constituent units. Another important feature of the method is the definitional-conceptual analysis, which is a refraction of the terminological material of the system analysis of vocabulary. On its basis, the system of economic terms is brought into line with the system of concepts of political economy, i.e. the definition of the meanings of terms is achieved, which is the main aspect of terminological work.

Definitional-conceptual analysis presupposes obligatory reference to extralinguistic facts and criteria, requires the use of the correlation of linguistic and social phenomena, consideration of linguistic phenomena in a broad linguo-social context.

The international nature of economic terminology predetermined the use of a comparative analysis of those languages that, due to certain historical reasons, were the main linguistic carriers of economic information.

**Conclusion.** The study of economic terminology cannot be effective outside the application of the entire system of basic principles and laws of dialectical and historical materialism, taking into account the specifics of a given object of knowledge.

Based on a critical revision of the views that take place in modern linguistic science on the problem of the term as a linguistic unit, we propose to interpret the scientific term as a product of the historical development of the word, associated with the theoretical level of knowledge.

It is necessary to approach the analysis of economic terminology in the unity of its part (term) and the whole (terminal system). Primarily the following features characterize the specificity of English economic terminology as a special lexical layer: "ideological coherence", "interventional-style homonymy", and the originality of internationalization processes. Attributing "general comprehensibility" to the specific features of this vocabulary is unlawful.

The specificity of political economic terminology predetermines the characteristic features of its analysis - first, the inseparable unity of lexicological and sociolinguistic approaches.

#### **References:**

[1]. Lenin V.I. Imperialism as the highest stage of capitalism. - Poly. coll. cit., vol. 27, pp. 299-426.



- [2]. Lenin V.I. Philosophical notebooks. - Poly. collected works, T. 29. - 782 p.
- [3]. Marx K. The Elections in England. - Tories and Whigs. - Marx K., Engels P. Collected Works, v.11. - M.: Progress Publishers, 1975, p.327-332.
- [4]. Engels F. Letter to Marx. June 24, 1867 - Marx K., Engels F. Soch., vol. 31, pp. 262-263.
- [5]. Marx K. Zur Kritik der Politischen Ökonomie: (Manuscript 1861-1863) - MEGA, Abt II, Bd.3.4. - Berlin: Dietz Verlag, - 1538 p.
- [6]. Materials of the Plenum of the Central Committee of the CPSU, June 14-15, 1983 - M.: Politizdat, 1983. - 80 p.
- [7]. On the further improvement of ideological, political and educational work. Decree of the Central Committee of the CPSU of April 26, 1979 - In the book: CPSU in decisions and resolutions of congresses, conferences, plenums of the Central Committee, v.13. M., 1980, pp. 353-368.
- [8]. Actual problems of linguistics in the GDR. Language, ideology, society. - M.: Progress, 1979. - 310 p.
- [9]. Akulenko V.V. Issues of internationalization of the vocabulary of the language. - Kharkov: Publishing House of Kharkov University, 1972. - 215 p.
- [10]. Akulenko V.V. scientific and technological revolution i problem in ternational terminology. - In the book: Scientific and technological revolution and the functioning of the languages of the world. M., 1977, pp. 73-84.
- [11]. Akhmanova O.G. Dictionary of linguistic terms. .2nd ed. - M.: Soviet Encyclopedia, 1966. - 607 p.
- [12]. Bally Sh. French style. - M.: Publishing house of foreign literature, 1961. - 392 p.
- [13]. Baskakov A.N. Peculiarities of terminology formation in different social conditions of language formation. - M.: Soviet sociological association, 1970. - 13 p.
- [14]. Bakhnyan K.V. Language and ideology: sociolinguistic aspect. - In the book: Language as a means of ideological influence. M., 1983, p. 34-58.

**UDC: 801.8**

**UNIQUENESS OF THE FICTION STYLE IN THE NOVEL “OTA”  
 (“FATHER”) BY ULUGBEK HAMDAM**

**Sabirova Dilorom**

**Researcher of Urganch State University,  
Teacher of Urganch Innovation University  
[dilorom.sabirova@mail.ru](mailto:dilorom.sabirova@mail.ru)**

**Annotatsiya.** Mazkur maqolada zamonaviy o‘zbek nasrida alohida o‘ringa ega bo‘lgan ijodkor Ulug‘bek Hamdam nasriy asarlari badiiyati xususida gap boradi. Xususan, adib qalamiga mansub “Ota” romanining personajlar tizimi, asarning o‘zbek va jahon adabiyotidagi bir qator mashhur romanlar badiiyati va personajlari bilan uyg‘unlik jihatlari haqida fikr yuritiladi.

**Kalit so‘zlar:** zamonaviy adabiyot, personaj tasviri, personaj nutqi, ota obrazi, folklor motivlari, polifonik bayon tiplari.

**Аннотация.** В статье рассматривается художественный стиль прозаических произведений Улугбека Хамдама, занимающий особое место в современной узбекской прозе. Освещается характерная система его романа «Ота» («Отец»), ее гармония с искусством и персонажами ряда известных романов узбекской и мировой литературы.

**Ключевые слова:** современная литература, образ персонажа, речь персонажа, характер отца, фольклорные мотивы, полифонические типы речи.

**Abstract.** The article discusses the artistic style of prose works by Ulugbek Hamdam, which holds a special place in modern Uzbek prose. It highlights the character system in his novel “Ota” (“Father”), its harmony with the art and the characters of several famous novels in Uzbek and world literature.

**Key words:** modern literature, character image, character speech, character of father, folkloric motifs, polyphonic speech types.

**Introduction.** Ulugbek Hamdam is widely regarded as one of the most accomplished modern writers in Uzbek literature. This view is shared by leading critics of Uzbek literary studies as well as many scholars in the field. Notably, Umarali Normatov, a renowned academic, has made the following remarks on Ulugbek’s work: “...For almost thirty years, Ulugbek Hamdam has been producing poetries and proses in a variety of genres including stories, short stories, and novels. He has also made a name for himself as a skilled translator... In addition to this, Ulugbek is an accomplished literary scholar with a Doctor of Science degree.

I had the pleasure of reading the manuscript of our brother’s new novel, “Ota” (“Father”) and I found it to be a unique work that differs from his previous works in terms of subject matter, imagery, and interpretation. The novel covers a range of events from the Second World War to the present day, portraying both the joyful and the tragic moments in the lives of over twenty different characters.

In this compact novel, the reader is introduced to the complicated and happy moments, as well as the strange fates, of a range of characters. Given the current state of our literature, where novels are struggling, this work breathes life into the genre” [4].

The works by Ulugbek Hamdam are highly recognized in the literary world, and his artistic level is evident in “Ota” (“Father”). Reading this novel is like returning to childhood. It is a work that reminds me of the works of Utkir Hashimov, particularly the opening sentence “Dedicated to all fathers” which echoes Hashimov’s “To all the mothers of the world”. By the end of the novel, the reader will notice the harmony between the events in the story and those in Shukrullo’s “Kafansiz Kumilganlar” (“Buried ones without shroud”).

**Methodology.** “Ota” (“Father”) is divided into three parts based on logical consistency. The first part, “Under the Blue Sky” (“Osuda Osmon Ostida”) portrays the lives of Uzbeks before the war. Mainly, the events about the young man “who had been married for fifteen years” and suffered from childlessness [4], tried to get help from azayimkhan (fortune teller) and mullahs in Tashkent are described.

The second part of the novel is called “Urush” (“The War”) and this part describes the experiences of those heroes in connection with the Second World War,

which is known for its destruction and carnage in the history of the world. The last and final section, titled “Kutish” (“Expectation”) features the main speaker.

The central characters are Pulat and Yogdu, and the main action in their family is trying to have a child, hoping to become a father. Also, Utkir brother and Aychechak sister, the owner of the apartment, are considered to be active characters in the play. As a powerful visual tool in this work of the writer, it is possible to note the emotional images presented in some places.

*“After all, I am a father, father! Was this world in the hands of the fathers or did it leave because of me? No, no, this cannot be allowed. Absolutely! If there are no fathers at the right time, the world will not be in its place: it will be broken. Look! I loved you so much. I didn’t want your face to burn and your heart to burn. I caressed and kissed you. So what happened next? You got pregnant by someone on the street! They say that such a child is a bastard, a bastard! Oh Allah, how did you allow this to happen? How can I bear it now? Will my grandson come to my house as a bastard?!.. No, it’s impossible!.. If I forgive them today, someone else will do it again tomorrow! I won’t let the next one happen! I will do what a father should do to uproot the idea that “it is possible to have a child like this” in people’s minds!.. Sevinch, until now you have seen the love of your father, now also his anger!.. Curse you for forcing me to do this, curse this fate!..” [1].*

It cannot be denied that the above sentences from Pulat father’s speech are extremely exciting, in which the writer has a high degree of visual ability.

In order to create a strong emotion in the above passage, the creator skillfully used the tactics of contrasting concepts with strong emphasis. Including, the juxtaposition of the concepts of “love” and “anger”, repeated use of words in the form of “I am a father, father!”, “Curse you”, “No, no, this cannot be allowed”, “I can’t put it”, sharp expressions such as “Pulling it out with the roots”, “No, it’s also impossible!”, rhetorical addresses such as “Did it leave because of me?”, “Oh Allah, how did you let this happen?” served as details that create strong emotional aspects of the work.

It is not difficult to notice the commonalities of the group of characters of the novel “Ota” (“Father”) by Ulugbek Hamdam with similar characters in Uzbek and world literature.

**Utkir brother** - Ulugbek Hamdam wants to show that he is a real Uzbek father. Not to mention the difference in years, it looks like Yusufbek Haji himself.

**Aychechak sister** reminded me of Uzbek oyi so much that I felt as if one soul lived in two bodies [1].

**Pulat** (rich man) (I found it permissible to use the suffix “rich”. Because there is no better definition for a person who has tasted all the love and pain of life.) - a collection of rare fathers in the world.

**Yogdu** – is a precious commodity of life. A symbol of perfect luck that can be given to a man by Allah’s grace.

**Sevinch** – is a sweet blessing that many people need in real life and have been praying for it for years.

**Erboy** is a hero like a stone created so that life is life, that there will always be conflicts, pains, injustices, and that fate does not deviate.

When talking about the symbol of father, it can be found and felt in almost all works. Opinions regarding the enhancement of written literature through oral literature can be found in various sources of Uzbek literary studies. Therefore, we believe it is important to note that the portrayal of the father exhibits similarities to numerous genres of folklore.

To support our opinion, we can refer to the fact that the word “father” in the Uzbek language is explained through folk proverbs. In the “Explanatory Dictionary” of the Uzbek language, the word “father” is defined as a man who has children (in relation to their children). Example: Ota bo‘lmay, ota qadrin bilmas [5]. It means that if you don't become a father, you don't know the value of a father.

The advice of a father can have a significant impact on a child's life. When a father approves of their child, it can lead to success and happiness in both this world and the hereafter. This is because, as the saying goes, “**Ota rozi – Xudo rozi**” [3], which means that if the father is pleased, the Allah is pleased. This idea is not limited to proverbs, but is also evident in various literary genres such as epics, narratives, and fairy tales found in folklore. The image of the father is highly regarded in these examples.

If we pay attention only to “Alpomish”, We can realize something in the speech of Kultoy's advice to Alpomish: “...*respect your parents, a child who displeases their parents will not succeed*”. His admonition puts respect for parents, who show the national identity of our people, in the highest place. The main idea of Ulugbek Hamdam's novel “Ota” (“Father”) is focused on creating a unique image of the father, based on Uzbek traditions and customs.

The figure of the father, like our ancient values, is a person who stands in a special position and is given great respect and attention. The image of the father is also in a high position in world literature. There are numerous examples of literary works on this topic, such as “Fathers and Children” by I.S.Turgenev, “Father Goriot” by Honore de Balzac, and “The Robbers” by Friedrich Schiller.

**Results and discussions.** In the Uzbek literature, there are many authors who created the image of father in their works. For example, “Utkan Kunlar” (“Days bygone”) by Abdulla Kadiriy, “Otamdan qolgan dalalar” (“The Fields Left by My Father”) by Pirimkul Kadirov, “Yulduzlar mangu yonadi” (“The Stars Shine Forever”) by Togay Murad, “Uzbek Baba” (“Uzbek Grandfather”) by Shukur Kholmirezayev, “Otam haqida hikoyalar” (“The Stories about my father”) by Mukhtar Khudoykulov, “Kismat” (“The Fortune”) by Isajon Sultan, “Oppoq qor” (“White Snow”) by Amon Mukhtar, “Uzra” (“Over”) by Fayzulla Salayev as examples. However, there are very few works in which the image of the “father” is widely covered, that is, brought to the level of the main figure, but there are [3].

The novel “Ota” (“Father”) by Ulugbek Hamdam is one of such works. The figure of “father” is chosen in the center of this novel, and the figure of mothers is also depicted in it. The universe was created so that all creatures were created in pairs. Therefore, it is impossible to portray figures such as father or child without the images of women and mothers.

The images of women in fiction have changed over time, and their characteristics have taken on a different color. Now, in the works created in Uzbek literature, the

image of a woman has shown its many facets. The works did not depict women's admonitions and conclusions. Instead, it began to give a wider place to the artistic interpretation of their place in society, their active struggle, as a bright manifestation of social life.

In the works of the current period, women are being interpreted as a participant of social life, as a fighter for family happiness and justice in society. The novel "Ota" ("Father") by Ulugbek Hamdam is distinguished by the different way of expression and subject structure [2].

In the novel "Ota" ("Father") by Ulugbek Hamdam there are female characters depicted at the unique level of character, such as **Aychechak sister, Yogdu, Sevinch**. It is not difficult to perceive and understand not only the father's but also the mother's desires and requests to a greater extent at the heart of desire, need and hope to have a child in the family.

Aychechak sister goes to various azayimkhans (fortune tellers), worried that her only child is passing away childless and that her generation will not continue. In the work, the character of Aychechak sister is depicted as a woman who believes in "bid'at" (useless traditions). His son Pulat tells everyone that he went to these azayimkhans (fortune tellers) when he was a child. He thinks that this is the result. Aychechak sister went to azayimkhans (fortune tellers) and learned what to bring to them.

We can take as an example that when their granddaughter Sevinch went missing, she took a piece of her shirt and went to the fortune teller. Aychechak sister tells them that she will sacrifice an ox for them if they find her grandson. She wants her children to be safe from accidents and pain [2].

In the character of Sevinch, an innocent teenage girl, a schoolgirl is depicted so attractively that it is possible to recognize that the writer has shown his high skills through the sentences in their speech. For example: *"...Hey, that's not the right thing to do, girl! After all, we agreed with you: apart from the fact that I am the father and you are the daughter, we also said that we are comrades and friends. Do you remember? Is this friendship? I see that something is bothering you. If you don't tell me, our friendship will not be true. It will be a lie. You are considered to have cheated me! Or are you trying to cheat?"*

- No...

- Tell me.

-Father, can I have other friends than you? Sevinch said sadly [4].

**Conclusion.** Different female characters in this work of U.Hamdam were created, some are old women who believe in ancient traditions, while others are depicted as teenagers and students who behave very modernly. Differences in their characters, views on understanding the world, and conflict of ideas are convincingly explained based on real-life events.

The novel "Ota" ("Father") holds a significant place in modern Uzbek literature due to its artistic colors and detailed portrayal of the characters. Studying the artistic methods used in such works proves valuable for contemporary Uzbek literary studies.

### References:

- [1]. Kurbanov S., Murodullayev A. The image of Pulat in the novel of “Ota” (“Father”) by Ulugbek Hamdam. Formation of Psychology and Pedagogy as Interdisciplinary Sciences.
- [2]. Olimjonova S. The image of a mother (woman) in the novel of “Ota” (“Father”) by Ulugbek Hamdam. Interdisciplinary innovations in Uzbekistan and journal of scientific research. 20.01.2023.
- [3]. Turdiyeva N., Khudoymurodova H. The image of the father in the novel of “Ota” (“Father”) by Ulugbek Hamdam. Youth, Science, Education: Topical Issues, Achievements And Innovations. 2022, –Prague, Czech Republic.
- [4]. Ulugbek Hamdam. Father. –Tashkent: New century generation, 2020.
- [5]. An explanatory dictionary of the Uzbek language. volume 3. –Tashkent: Uzbekistan national encyclopedia, 2008.

## **ACTUAL PROBLEMS IN MODERN ART AND ARCHITECTURE**

**UDC: 684.561.02.133**

### **SCIENTIFIC THEORETICAL ASPECTS OF STUDYING THE DEVELOPMENT OF INDUSTRIAL AND INTERIOR DESIGN**

**Salakhidinov Masuddin Sadriddinovich**

**National painting named after**

**Kamoliddin Behzod and**

**Institute of design. Direction  
of design history and theory.**

**[Masuddin@mail.ru](mailto:Masuddin@mail.ru)**

**Annotatsiya:** Maqolada sanoat va interyer dizayni rivojlanishini o‘rganishning ilmiy nazariy aspektlari va o‘quv-tarbiya jarayonini oqilona tashkil etish va yetuk mutaxassis kadrlarni tayyorlash muhim xususiyatlari haqida batafsil bayon qilingan.

**Kalit so‘zlar:** ijtimoiy-siyosiy, iqtisodiy, huquqiy, madaniy, o‘quv-tarbiya, ergonomika, psixologiya, sotsiologiya, biomexanika, kontstruktorlik, texnologiya, dizayner.

**Аннотация:** В статье подробно описаны научно-теоретические аспекты изучения развития промышленности и дизайна интерьера и важные особенности рациональной организации учебно-воспитательного процесса и подготовки зрелых специалистов.

**Ключевые слова:** социально-политическая, экономическая, правовая, культурная, образовательная, эргономика, психология, социология, биомеханика, конструирование, технология, дизайнер.

**Annotation:** The article details the scientific theoretical aspects of studying the development of industrial and interior design and the important features of the rational organization of the educational process and the training of mature specialist personnel.

**Keywords:** socio-political, economic, legal, cultural, educational, ergonomics, psychology, sociology, biomechanics, constructor, technology, designer.

**Introduction.** The current significant socio-political, economic, legal, cultural changes in the world make qualitatively new requirements for the content and character of the work of qualified designers. This situation assumes a complex approach to the problem of training qualified designers. The integrated approach to the training of qualified designers, in its place, calls for a rational organization of the educational process and the development, improvement and integration of the content of the training of mature specialist personnel.

The design, which appeared in the last quarter of the 19th century – the beginning of the 20th century, has become the most significant type of project-artistic activity in the history of its centennial development. Today it covers all the areas that surround man (industry, architecture, mechanical engineering, advertising, etc.) covering. The modern design project is an integrated process and harmonizes the scope of various specialties such as economics, marketing, ergonomics, psychology, sociology, biomechanics, construction, technologist. In modern post-industrial society, design is moving beyond the limits of its traditional interpretation of Project culture in relation to form construction.

**Literature review.** Literature about the history of design or design education is not so much in the Uzbek language and even in World theory, but sources of its study can be found in different areas of peat (for example, fashion, industry, advertising, mechanical engineering, architecture). In the research work, we sought to shed light on the various points of view formed in recent decades, to rely on them in the description of certain processes.

Also, research, books and articles on the art of industrial and applied decoration form the source material of the dissertation. Because, most of the factors of the artist's career as a designer appeared long before the emergence of the concept of design. Literature on design became popular in the world by the 1930s, at which time opposite positions arose, theoretical developments related to design practice began to form. Nevertheless, the literature on design is not so much to divide them into groups according to their general quality.

The role of Herbert Reed (1893-1968) in the development of design theory is enormous. He attributed the history of design to the character of modernism, trying to substantiate the role of the artistic evolution of design in the search for the construction of one form or another coming from art. G.Reed's Book "Art and industry", historically and theoretically devoted to the problems of the two spheres, is devoted to the disclosure of the essence of form and form construction, color and ornament. Its conclusions are still relevant today, and it suggests that it is not permissible to conform an industrial product to aesthetic criteria based on an analysis of the issues of the relationship of beauty and form, but rather, the need to "develop new aesthetic criteria in accordance with new methods of production." [1]

The research of Nikolaus Pevzner (1902-1983), a historian of European architecture and design, is of particular importance in the study of the theoretical foundations of design. Based on his observations of the Fine Arts industry in England, he wrote "Pioneer sovremennogo dwijenius. OT Willyama Morrisa do Valtera Gropiusa "[2], becomes the author of books such as "Study on the industrial arts of England", "designer in industry". Through the static analysis of reports on the



development of archival resources, England's Manufactory, Pevzner reveals the place of English design in world design, covering artistic, architectural and designer creativity. The scholar also tries in his book "The Sources of Modern Architecture and Design" [3] to clarify references to *ar-nuvo* and international style, which were widely developed in architecture and design at the beginning of the 20th century. Professor Pevzner clarifies stylistic principles of a confusing period, relying on about two hundred examples of 20th-century architecture and Applied Art.

**Research methodology.** Design theory and design education in developed countries has more than a hundred years of history and experience, but in Uzbekistan this area is a relatively new educational direction, experiencing a process of development with a rapid image in the modern artistic process. Nevertheless, to date, there is no scientific literature on design theory in Uzbekistan, except for a small dissertation on the development of industrial and interior design and scientific articles that evoke long-distance imagery.

Art Historian K. Akilova attempts to explain the objective reasons for this: "on the one hand, in our opinion, this is due to the insufficient study of the history and theory of design in higher and secondary educational institutions. Students and students are often given practical skills that are used in the process of working on design objects, but little attention is paid to the philosophy and concept of design. On the second hand, design theory is a separate new field for researchers, and it is not actualized in the list of research ciphers. The OAK register defines the field's scientific passport as "Technical Aesthetics and design" [3].

**Analysis and results.** Today, there are no fundamental studies in Uzbekistan, except for several scientific literature on modern design. Socio-cultural life in Uzbekistan in the 21st century has been actualized by a consistent study of the design field, the implementation of its achievements in the educational process. After the issuance of a scientific passport for the direction by the Supreme attestation Council of Uzbekistan in a special cipher "17.00.05 – theory and history of Design", Research on dress design, landscape design began to appear. [4]

This research led to the emergence in our country of theory and history of design types, problems in the field of design, world and Republic design, comparative analysis of design education processes.

In Particular, O. In Kasimov's study, urgent issues such as the further development of landscape design architecture, ensuring ecological balance in urban planning, the introduction of modern methods, the effective landscape Organization of territories through the mutual harmonization of Urban Architecture, Landscape Architecture and design, using the rich heritage accumulated over the centuries. [5]

I. S. Baydzhonov's teaching manual "foreign modern architecture" [6] describes the processes that have been going on in World Architecture since the late 19th century to this day, the specificity of architectural styles. Naturally, since design is inextricably linked with architecture, this methodological literature is considered purposeful in training designer specialists.

In Uzbekistan, articles in a number of OAK presidium journals as well as scientific conference theses covered some issues related to the topic of research. Research on design theory is regularly covered in the periodical scientific journal "art".

M.Mirpolatova covered such issues as directions in architectural and interior design, restoration of the city's ecobalance, research on preservation, the role of ethno-design in maintaining a national image, originality, which became popular in today's century.[7] Z.Babayev and H.In his scientific article, Rakhmonov conducted scientific research on methods of improving the ability of designers in students of secondary-special educational institutions.[8] Z.Aliyeva in the article "Subject I interior design of Uzbekistan" approaches to cultural studies in the field of design, the main factors of the appeal to ethnoans, focuses on scientific and technical processes, environmental and social problems.[9]

Even in the post-Soviet states during the years of independence, design problems were raised as an urgent issue in a number of art schools. In particular, a number of studies have been carried out on the theory of design in Azerbaijan. E.In Aliyev's opinion, modern design is directly related to the visualization of culture, and in its place it "reflects the processes of transformation of its metazabon, the transformation of the cartoon of the universe with peat diversity – national, social, scientific, artistic." According to the author, design is a kind of art that occupies the cultural space of the postmodern, a reflection of the Western world cartoon that manifests its archetypes in the late invaders of European culture. Obviously, design is an area that, along with artistic symbolism, is aimed at certain consumer standards and levels, or vice versa – at consumer culture.[9]

Vyacheslav Glazichev's book "About design: Essays on the theory and practice of design in the West" attempts to clarify theoretical ideas about the factors of the history of the emergence of design, the specific features of modern Western design, design that have retained their relevance to this day. The author tries to determine the degree of its involvement with art based on the analysis of the views of design theorists.[10]

Also, L.N.Klimova's dissertation carried out analytical research on the theoretical foundations of design-education in the formation of a creative personality based on foreign and domestic qualifications, innovative approaches to design-education in author's schools, organizational and pedagogical conditions of Project-art education in the college and the pedagogical model of implementation technology. [11]

**Conclusion and recommendations.** Specialized design schools have a number of design tutorials and textbooks, and it is through these literature that students are taught. T.Hidoyatov, S.Kadirov, Y.The educational manual "modern equipment and interior", created by Abdurakhmonov in his co-authorship, highlighted the issue of factors of the organization of the Interior, its aesthetic characteristics, the basic principles of design, harmony with the interior composition of the equipment.[12] the team of authors revealed the functional feasibility of the interior, the adaptation of the composition to the social climate, conditions, the functional-spatial basis of its organization, the form and Color Solution of the equipment in the apartment on the example of World Architecture.

### References

- [1] Reed Herman. Art and industry. 1934.
- [2] Nikolaus Pevsner. Pioneers of Modern Design: From William Morris to Walter Gropius; Revised and expanded edition. – 2005. ISBN: 0300105711



- [3] Akilova K. Theoretical Design, operations and innovations are welcome. SAN'AT. – Toshkent. 2014. No. 3. - B.6-10.
- [4] Atakhanova F.Z. Traditions and innovation in modern Uzbek design / 17.00.05 – design theory and history, art. fan. Fal. dissertation written for the degree of doctor (PhD). - Tashkent: 2021. - B.120.
- [5] Kasimov O. S. Formation of landscape design of modern residential environment of Tashkent City / 17.00.05-design theory and history, art. fan. Fal. an autograph written for the degree of doctor (PhD). - Tashkent: 2021. - B.41.
- [6] Baydzhannov I.S. Foreign modern architecture. - Tashkent: 2020.
- [7] Mirpulatova M. Eco and ethno design are popular design trends of the XXI century. SAN'AT. – Toshkent. 2016. №1.
- [8] Boboeva Z. Rachmanoff H. Formation of designer skills in the educational process of students. Oriental Renaissance: Innovative, educational, natural and social sciences. VOLUME 2 | ISSUE 12. B. 1017 - 1023

**UDC: 687.561.02.133**

## **CONSTRUCTIVE PARAMETERS OF PRODUCTS IN ERGONOMIC DESIGN OF SPECIAL CLOTHES**

**Yunuskhodzhayeva Khairinisa Mallaevna**  
Associate Professor, Tashkent Institute  
of Textile and Light Industry  
Department of Costume Design,

**Yunuskhodzhayeva Lilufar Daniyarovna**  
Assistant, Namangan Institute  
of Textile Industry  
Department of “Design”

[yunuskhodzhayevalilufar@gmail.com](mailto:yunuskhodzhayevalilufar@gmail.com)

**Annotatsiya:** Kiyim dizayni estetika, ishlash va qulaylik talablari bilan belgilanadi. Ergonomika ishchini ish joyiga moslashtirishga harakat qilishdan ko‘ra, ishchining ehtiyojlariga mos keladigan ish joyini loyihalashni o‘z ichiga oladi. Maqolada maxsus kiyimlarning ergonomik dizaynida mahsulotlarning konstruktiv parametrlarini loyihalashda tadqiqot haqida so‘z boradi.

**Kalit so‘zlar:** maxsus kiyim, ergonomik loyihalash, konstruktiv parametr, dizaynda loyihalash, dizayn, muhit, himoya.

**Аннотация:** Дизайн одежды определяется требованиями эстетики, производительности и комфорта. Эргономика включает в себя проектирование рабочего места в соответствии с потребностями работника, а не попытки приспособить его к рабочему месту.

**Ключевые слова:** специальная одежда, эргономичный дизайн, конструктивный параметр, дизайн в дизайне, Дизайн, окружающая среда, защита.

**Annotation:** Clothing design is determined by the requirements of aesthetics, performance and comfort. Ergonomics involves designing a workplace to suit the needs

of the worker, rather than trying to adapt the worker to the workplace. The article will talk about research in the design of constructive parameters of products in the ergonomic design of special clothing.

**Keywords:** custom clothing, ergonomic design, constructive parameter, design in design, design, environment, protection.

**Introduction.** In recent times, there has been an increase in current issues related to clothing. The increase in the number of consumers and users looking for products that are differentiated and tailored to their needs and expectations will affect the design stages, as well as the production process. Thus, understanding certain segments of consumers and users appears as a competitive strategy that is convenient for different individuals to develop suitable and satisfying products.[1]

In the context of fashion, clothing products provide channels of meaning and subjective identification at the emotional level. This section deals with the application of anthropometry and ergonomic design principles to the problem of clothing design. The term clothing refers to a coating for the human body. In general practice, several such layers are worn at any time in the form of underwear or outerwear.

The main requirements of clothing are: protection from the external environment - heat, cold, wind, rain, etc.; maintaining a micro-environment - allows you to transport heat and moisture from the body; applying minimal delimitation - allow you to move freely and perform tasks; ease of Use - wearing and removing clothes.

**Literature review.** Given the direct connection between clothing and the user, anthropometric biomechanical and ergonomic data are necessary to develop modeling tailored to the different needs of different segments of users.

During work, a person experiences comfort or discomfort, heat and coldness, comfort, psychological sensations of pressure on certain parts of the body, which affect the fatigue and performance of a person. Therefore, the creation of ergonomic clothing requires that the form of clothing fully comply with the anthropometric characteristics of the human body and comply with ergonomic requirements.[2]

As you know, special clothes should provide a high level of ergonomics and provide comfort for the user with the necessary level of protection, which should correspond to the working conditions of workers, the environment and the level of physical activity. It is impossible to design an outfit without assessing ergonomics, which confirms its practicality and safety.

The ergonomics of protective clothing must meet the special clothing requirements of workers. In order to develop an ergonomically reasonable design to match dynamic compliance, the most typical actions of workers during work were studied. In working conditions, the following tests were carried out: visual assessment of the quality of product testing and product installation, horizontal up and down lifting of both hands, assessing the convenience of Product Design in dynamics, taking pictures of the product to workers in the specified movement indicators, dynamics.

Based on the results obtained in the process of studying the measurement characteristics of workers in special clothing, ergonomic filming of the working day for thirty days was carried out in order to update the reliability of the initial observations. The results of the initial observations, non-relevant actions were

excluded, and frequent actions were introduced. The final ergonomic picture of the working day was formed at the end of the studies.[3]

The most relevant and often performed movements during the use of special clothing are the movement of the hands, lifting them forward and up, sprains in the elbow and shoulder joints, sprains of the legs in the knee joint with the bending of the body. To understand the complexity of the integration of body and clothing, it is necessary to study anatomy and body movement.

It is important to understand the balance plans of the input body, as well as its movements such as flexion, extension and others. Thus, the multiple and interdisciplinary interaction between the clothing project and ergonomic design contributes to the development and resolution of the clothing projects project. Understanding the concepts of comfort, comfort and ergonomics inherent in certain groups is necessary in order to obtain fashion samples that correspond to their expectations and requirements.[4]

Fashion metamorphosis has helped define the social and specific role of subjects through the hierarchical use of fashion's various clothing and accessories throughout the evolution of societies. Its symbolic nature reflects the subjective and cultural aspirations of a certain period, which, in turn, significantly reflects the physical and constructive aspects of fashion products, especially clothing.[3]

Symbolically, given the physical and material aspects of clothing, one can see the infinity of changes that represent the social cultural and technological context of a given period. Fashion innovation has disrupted the rigid structure of corsets that put pressure on women's abs and is designed to create and define a thin waist, a raised chest and the right position.[5]

**Research methodology.** Thus, under the new industrial characteristics adapted to the growing requirements of the sewing product, a rapid production system began to be used. The new industrial system helped to make a big difference in the process of creating and developing fashion products.

With the advent of mechanization and mass production, the demand for products has increased significantly due to new social groups with high purchasing power and new forms of consumption, consequently, this system has rapidly spread in several regions of the world, helping to strengthen the textile industry in HFM as well.

The stages of clothing design and planning became increasingly sophisticated in relation to new textile and industrial technologies, as well as more sensitive to social and cultural movements. The hedonistic consumption became more and more intense, primarily with the aesthetic and symbolic elements of fashion products.[6]

With industrial production, measurements of clothing shapes and sizes began to become important to cover the measurement standards of some individual variations. It will be possible to identify the user if he knows them well, recognizes their needs, capabilities and limitations. the occurrence of accidents, health damage and discomfort in advance. Consequently, individuals are gradually seen as users rather than as ordinary consumers.

In this process, the interdisciplinary characteristic of ergonomics is perceived as a contributing factor to mediation between body and clothing, a science that can offer the user constructive tools that can be able to ensure safety, comfort and health.

From the point of view of fashion, to create a product of aesthetic and ergonomic quality, it is necessary to analyze all the articulation of the body that is in direct contact with or holds the garment. Convective modeling primarily uses user statistics such as waist, thigh, and neck circumference; body or arm length; etc.[6]

**Analysis and results.** This information affects the size of the garment. Alternatively, the individual contributions of certain segments of users will help to correctly draw or shape certain parts of the garment, which must be specific and suitable for different needs and expectations describe this fact.

Each region of the body must be analyzed in order to correctly inform about how clothing works in connection with physical movements. For example, hands, feet, thighs and heads perform several actions that can contradict certain characteristics in specific clothing, such as narrow sleeve armholes or collars, loose paints, etc.[4]

Consumers are increasingly looking for fashion products that offer unique physical qualities such as comfort. In this context, innovation and differentiation strategies are located ahead of competitors who are important to support the relationship between the product and the user, as well as the brand.[1]

**Conclusion and recommendations.** To do this, understanding the specific segments of the consumer and users appears as a competitive strategy that is favorable to specific needs and desires for adequate and satisfying fashion products. Therefore, understanding the factors that can affect the purchase and use of a piece of clothing will be necessary to control the process of designing fashionable products. From this logic, the biophysical, anthropometric and social characteristics inherent in each segment of interest must always be taken into account in the creative process.

These variables, when handled and applied correctly, add value to the product through partnerships and integrity in the user-Action Task-clothing interaction. In addition, taking into account the close connection between clothing and the body, the fashion product creates the value of considerations inherent in the perception of certain aspects, such as usability, likability, comfort, pleasure, satisfaction of individual and subjective needs. Clothing design is determined by aesthetics, performance and comfort requirements.

### References

- [1] Wang, X., Wu, J.: Ergonomics of practical design. China Textile University Press. (2001).
- [2] Xu J., Tao, K. Human engineering. China Textile Press (2002) Chen, J.: Spacesuit Engineering. National defense industry press Jia. S. (2004).
- [3] Chen J. The physiological basis of human mechanics and its application in the design of a pressure suit. Space medicine and medical engineering. (1999).
- [4] Jiang Q.J (Jiang, Qiao-Xuan); Dai, H (Dai, Hong): designing clothes for construction workers based on clothing ergonomics.
- [5] Textile bioengineering and informatics symposium materials, 2014, Volume 1. and 2. Book series: textile bioengineering and informatics symposium materials.
- [6] Yunuskhajeva H.M.Kamilova Kh. Kh. Development of a functional and ergonomic national basic design of special-purpose clothing. ACADEMICIA: An International Multidisciplinary Research Journal. ISSN: 2249-7137 Vol. 12, Issue 05, May 2022.

## ACTUAL PROBLEMS OF NATURAL SCIENCES

UDC: 910.2

### STEPS OF TEACHING STATISTICAL METHODS IN ECONOMIC AND SOCIAL GEOGRAPHY

**Djumabayeva Salomat Kamiljanovna**  
**Chirchik State Pedagogical University**  
**Associate Professor of the of Geography,**  
**Faculty of Natural Sciences**  
[DjumabayevaSalomat@gmail.com](mailto:DjumabayevaSalomat@gmail.com)

**Annotatsiya.** Iqtisodiy va ijtimoiy geografiya darslarida talabalarga statistik ko'rsatkichlarning mohiyatini, ularni hisoblash, tahlil qilish va izohlash malakalarini shakllantirishning to'rt bosqichi ajratilgan. Har bir bosqichda amalga oshiriladigan ishlar va ularning xususiyatlari izohlangan.

**Kalit so'zlar:** iqtisodiy va ijtimoiy geografiya, aholi, bosqich, demografiya, absolyut ko'rsatkich, tug'ilganlar soni, statistika, sanoat, transport.

**Аннотация.** На уроках экономической и социальной географии у учащихся выделяются четыре этапа формирования сущности статистических показателей, навыков их расчета, анализа и интерпретации. Разъясняются работы, выполняемые на каждом этапе, и их особенности.

**Ключевые слова:** экономическая и социальная география, население, этап, демография, абсолютный коэффициент рождаемости, статистика, промышленность, транспорт.

**Abstract.** In the lessons of economic and social geography, students are divided into four stages of developing the skills of calculating, analyzing and interpreting the essence of statistical indicators. The work to be carried out at each stage and their characteristics are explained.

**Key words:** economic and social geography, population, stage, demography, absolute figure, number of births, statistics, industry, transport.

**Introduction.** One of the most researched areas of geography in higher education is economic and social geography. Students are forced to work harder on themselves because this subject, in particular, contains complicated knowledge about the population's economic (output), social (consumption), and demographic (regeneration of the population) aspects. Statistical indicators offer improved data integration in this aspect. Economic and social geography generally have a direct relationship with statistics and frequently employ its indicators.

A well-thought-out technique is required to teach students to work with statistical indicators characterizing the economic and social condition, and with the aid of this, the efficacy of students' cognitive activity can be boosted. Teaching technology is one strategy to address students' academic issues, in line with E.N. Kabanova-summary Meller's of the theories of techniques and student mental growth. They are made up of activities grouped from various (big, small) systems. According to D.N. Bogoyavlensky, "a system of processes or operations of analysis, synthesis, abstraction, generalization, etc. specially arranged for handling certain types and

different degrees of complicated problems is what is meant by “methods of mental activity.” [1]

Based on the above, with the help of statistical indicators in the study of economic and social geography, students’ calculation methods consist of several sequential logical processes and actions combined with a common goal. Based on the methodology of working with statistical indicators applied by N.N.Petrova, all methods of working with statistical data can be used in the practice of studying economic and social geography. [2] These are the following:

- collecting the necessary statistical data;
- comparison of selected characters;
- determination of complex statistical indicators;
- analysis of all materials;
- preparation of tables, graphs, diagrams.

**Analysis and results.** At the same time, the system of tables, diagrams and indicators is also important in the methodology of economic and social geography of higher education. It is necessary for teachers of higher education to form students the essence of statistical indicators, their calculation, analysis and interpretation skills. The methodology of teaching statistical indicators of economic and social geography in geography of higher education includes the following four stages.

**Step 1** - formation of statistical indicators: mathematical materials serve as the basis for performing these actions. At this stage, indicators are named using numbers and letters.

In economic and social geography, letters of the Latin and Greek alphabets are mainly used for this purpose. In addition, we suggest replacing them with local alphabet letters. The reason is that they are more understandable to students than Greek letters. For example, AS is the population; AZ - population density, EFS - land use efficiency, SFS - water use efficiency, TK - natural reproduction, etc. This allows students to connect indicator names with letter symbols and reinforce their knowledge.[3] At the same time, as in other subjects (physics, chemistry, mathematics), it can be used in combination (alternately). For example, in the population density formula, the area of the territory can be designated as Latin “S” or Cyrillic “M”.

In our opinion, in the scientific naming of some statistical indicators, its change should also be taken into account. For example, “territorial production complexes” TPC (HICHM) - changed over time, non-production complexes were added to it and renamed as territorial complexes - TC (HM). [4]

**Step 2** - identification of information and clarification of signs of its application, this stage allows students to apply theoretical knowledge in practice. The definition of the indicator used and its name should be scientific and not too complicated for students to understand. It’s better to keep it relatively simple. Usually, the result of a production, composition in percent (%), birth, natural reproduction, salinity of water is given in ppm (‰). Some higher rates may be expressed in larger numbers (ten thousand, one hundred thousand, etc.). In economic and social geographical studies, arithmetic mean, geometric mean, balance, fashion indicators are also used. [5]



It should be noted that it is appropriate to use this indicator in specific educational conditions, on a specific topic of the lesson. The topics describe phenomena related to agriculture, industry, transport, or population geography and demography, as well as their territorial characteristics. The teacher should set the tasks in absolute or relative terms, determine its similar value together with the students, and then, using an example, teach its direct use in several stages.

**Step 3** - creating a mathematical model. In this case, the teacher should provide the students with the calculation formula of the problem to be worked on and define its measurement units. Here, the teacher should not just distribute the examples, but should provide the students with information about each of them. For example:

The absolute indicator of natural population increase is expressed in the difference between the number of births and deaths and is determined using the following formula.

$$K=T-O'$$

Here, K is the natural increase; T-number of births in a certain period; O' - is the number of deaths in a certain period.

Its relative indicator is used when comparing natural population growth by world regions, countries, individual regions, districts. On the basis of an absolute indicator, regions cannot be compared, because the population of each region is different, and the number of births and deaths in them depends on the total population. The relative indicator of the natural increase of the population is determined by the coefficient of the natural increase of the population. Population natural reproduction coefficient represents the absolute rate of natural reproduction per 1000 inhabitants in per thousand (‰).

The coefficient of natural reproduction of the population is determined using the following formula.

$$Kk = \frac{K}{S} \times 1000$$

Here, Kk is the coefficient of natural reproduction; K – natural reproduction; S - the average number of the population in a certain period; 1000 per 1000 people.

Also, the coefficient of natural reproduction of the population can be known from the difference between the birth rate and the death rate. For this, it is necessary to determine the birth and death rates.

The birth rate represents the number of children born per 1000 inhabitants in per thousand (‰) and is determined using the following formula.

$$Tk = \frac{T}{S} \times 1000$$

Here, Tk is the birth rate; T – number of births; S - the average number of the population in a certain period; 1000 per 1000 people.

In this case, we will not write the formula in a ready-made form, but consider the most optimal development ways to obtain it based on the definition of the indicator. It should be remembered that the definition of the indicator and the content of its formula, although related, are not the same. Knowing the meaning, you can make a formula, and conversely, knowing how to read the formula, you can give a definition of the

calculated indicator. For example, the death rate is the number of deaths per 1,000 of the population per year. Knowing this definition, students can formulate its formula. To calculate it, it is necessary to divide the number of deaths in the country in one year ( $O'$ ) by the annual population ( $S$ ) and multiply this ratio by 1000. So, the formula for this indicator is:

$$O'k = \frac{O'}{S} \times 1000$$

Here,  $O'k$  is the death rate;  $O'$  is the number of dead;  $S$  - the average number of the population in a certain period; 1000 per 1000 people.

If the birth and death rates are known, the rate of natural reproduction is determined using the following formula.

$$Kk = Tk - O'k$$

Here,  $Kk$  (CNR) is the coefficient of natural reproduction;  $Tk$  (BR) – birth rate;  $O'k$  (DR) is the death rate.

**Step 4** - practical interpretation of the digital indicator. After the calculations are done, the geographical analysis is carried out. It is very necessary to teach students about statistical indicators that describe the economic and social geographical situation.

**Conclusion.** The teacher always monitors how much the work done with the help of the mathematical model is strengthened in practice. In the process of strengthening methodological knowledge, students acquire the skills of calculating and analyzing indicators first together with the teacher, and then independently. A number of simple tasks are given to perform the calculation, which can be presented as an element of practical work (it is also possible to have several options using the form of teaching in groups). For example, using the above formula, the industrial, agricultural production of regions (continents or countries) is compared with each other or with the average indicators of other regions. In addition to mathematical calculation, students can be asked to show the values obtained in a graphical or cartographic form.

In addition to these, we believe that working with statistics can include data comparison, calculation, systematization, graphical interpretation, numerical data analysis and summarization, and the use of questions and assignments.

### References

- [1] *Psicologia formirovanie ponyatij i umstvennyx deystvij*. - M.: Izd-vo APN RSFSR, 1966. - 227 p.
- [2] Petrova N.N. *Methodology of teaching geography in a differentiated school*. - M.: Blik i Ko, 2000. - 336 p.
- [3] Namozov J.A. *Geography of the use of land and water resources (based on the materials of the Samarkand region)*. Monograph. Chirchik, 2022.
- [4] Soliev A.S. *Theoretical foundations of regional complexes*. T., 2003
- [5] Soliev A., Karshiboeva L. *Theoretical and practical issues of economic geography*, T., 1999.
- [6] Tojiev Z.N. *Population geography*. T., 2010.
- [7] Kyiv: Radyanska school, 1983. - 192 p.
- [8] Petrova N.N. *Methodology of teaching geography in a differentiated school*. - M.: Blik i Ko, 2000. - 336 p.



UDC: 546.47;547.327;577.112.3; 539.26;546.05;548.315.2;548.736.35

## SYNTHESIS AND CRYSTAL STRUCTURE OF THE Zn (II) ION COMPLEX WITH PARACETAMOL AND GLYCINE

**Khalillayev Murad Mukhamadsharifovich**  
PhD student the Khorezm Ma'mun Academy  
[murod.xalillayev@mail.ru](mailto:murod.xalillayev@mail.ru)

**Azizjanov Khushnud Maxsudovich**  
Urgench State University, department of  
Chemistry,  
candidate of chemical sciences, associate professor  
[hushnud@mail.ru](mailto:hushnud@mail.ru)

**Khasanov Shodlik Bekpulatovich**  
PhD., Deputy Chairman of Khorezm Ma'mun  
Academy for Scientific Affairs  
[shadlik@mail.ru](mailto:shadlik@mail.ru)

**Khudoyberganov Oybek Ikromovich**  
PhD., senior researcher of Khorezm Ma'mun  
Academy  
[oybek\\_hudoyberganov@mail.ru](mailto:oybek_hudoyberganov@mail.ru)

**Abdullayeva Zubayda Shavkatovna**  
PhD., senior researcher of  
Khorezm Ma'mun Academy  
[zubayda.abdullayeva.91@mail.ru](mailto:zubayda.abdullayeva.91@mail.ru)

**Annotatsiya:** Ushbu maqolada  $[Zn(L_1)_2(Gli)_2] \cdot 2H_2O$  ( $L_1$ -paratsetamol, Gli-glitsin aminokislota) kompleks birikmasi sintezi va uning kristall tuzilishi muhokama qilingan. Shu bilan birga, reaksiya unumining vaqt, harorat va reagentlar konsentratsiyaga bog'liqligi ham o'rganilgan. Sintez qilingan kompleks birikma IQ-Furye-spektroskopiya, element analiz va rentgen strukturaviy analiz usullari yordamida o'rganildi. Kembrij kristallografik ma'lumotlar (CCDC-2023) bazasi tahliliga binoan, 2023-yilgacha paratsetamol (atsetaminofen, para-gidroksiatsetanilid)ning 142 ta, glitsin (aminosirka kislota) ning esa 1430 ta metall komplekslari olingan va tuzilishi aniqlangan. Ilk bor paratsetamolning biogen element rux va aminokislotaladan iborat  $[Zn(L_1)_2(Gli)_2] \cdot 2H_2O$  tarkibli kompleks birikmasi sintez qilinib, monokristallari o'stirildi.

**Kalit so'zlar:** Koordinatsion birikma, paratsetamol, glitsin, element analizi, rentgenstrukturaviy analiz, monokristall, dimetilformamid (DMFA).

**Аннотация:** В данной статье рассматривается синтез комплексного соединения  $[Zn(L_1)_2(Gli)_2] \cdot 2H_2O$  ( $L_1$ -парацетамол, Gli-аминокислота глицин) и его кристаллическая структура. Кроме того, в исследовании основное внимание уделялось зависимости течения реакции от времени, температуры и концентрации реагента. Комплексное соединение анализировали различными методами, включая ИК-Фурье-спектроскопию, элементный анализ и

рентгеноструктурный анализ. По данным анализа Кембриджской кристаллографической базы данных (CCDC-2023) до 2023 года получено 142 металлокомплексов парацетамола (ацетаминофен, парагидроксиацетанилид) и 1430 металлокомплексов глицин (Аминоуксусная кислота) и определены их структуры[1,2]. Впервые синтезировано и выращено монокристаллы комплексного соединения парацетамола, состоящего из биогенного элемента цинка и аминокислот  $[Zn(L_1)_2(Gli)_2] \cdot 2H_2O$ .

**Ключевые слова:** Координационное соединение, парацетамол, глицин, элементный анализ, рентгеноструктурный анализ, монокристалл, диметилформамид (ДМФА).

**Abstract:** This article discusses the synthesis of the complex compound  $[Zn(L_1)_2(Gli)_2] \cdot 2H_2O$  ( $L_1$ -paracetamol, Gly-glycine amino acid) and its crystal structure. At the same time, the dependence of the reaction yield on time, temperature and concentration of reagents was also studied. The synthesized complex compound was studied using IR-Fourier spectroscopy, elemental analysis and X-ray structural analysis methods. According to the analysis of the Cambridge crystallographic database (CCDC-2023), 142 metal complexes of paracetamol (acetaminophen, para-hydroxyacetanilide) and 1430 metal complexes of glycine (aminoacetic acid) have been obtained and their structures determined by 2023. For the first time, a complex compound of paracetamol consisting of biogenic element zinc and amino acids  $[Zn(L_1)_2(Gli)_2] \cdot 2H_2O$  was synthesized and monocrystals were grown.

**Keywords:** Coordination compound, paracetamol, glycine, elemental analysis, X-ray structural analysis, single crystal, dimethylformamide (DMFA).

**Introduction:** There is a growing interest in synthesizing metal complexes of biologically active compounds with biometals and studying their physicochemical properties. It is important to use these compounds as antibiotics and anti-inflammatory preparations in pharmaceuticals, biologically active substances in medicine and antibacterial active substances that inhibit the growth of bacteria for microorganism cells. Complex compounds are used for a variety of biological processes, and the interest in them is growing. These compounds are made up of ternary systems consisting of biometals, bioactive ligands, and amino acids. The mixed ligands found in these systems serve as the basis for many biological processes [3]. The elements formed from them belong to the class of compounds containing nitrogen and oxygen, and they are widely used in medicine as various drugs.

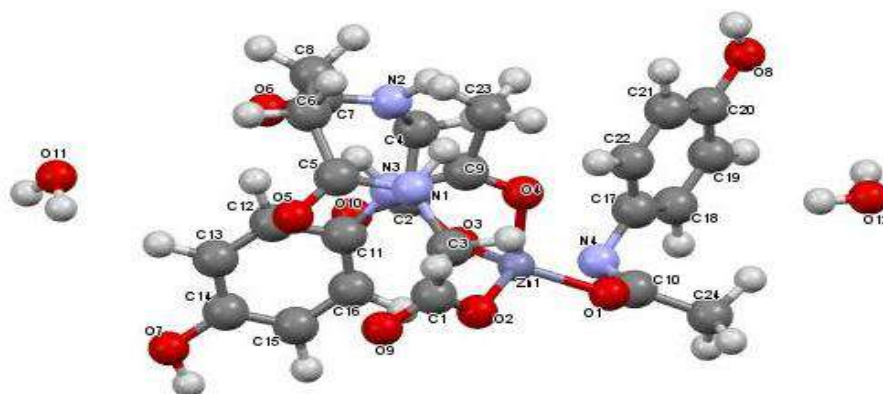
**Literature review:** Scientific research aimed at determining the synthesis of complexes of paracetamol with biometals, their spatial structure, “bioactivity-structure” relationship is being conducted in leading scientific centers and higher educational institutions of the world, including Delhi Institute of Pharmaceutical Sciences and Research (India), Institute of Inorganic Chemistry of Aachen University (Germany), Institute of General and Inorganic Chemistry, Moscow State University (Russia), University of Tokyo (Japan), Royal Institute of London (England). As a result of world research on the structure of complexes of acetaminophen with biometals and their biological activities, a number of scientific results were obtained, including the following: synthesis of metal chelate complexes was carried out, their spatial structure and charge density were determined (Institute of Inorganic Chemistry of Aachen



University, Germany); mixed-ligand coordination compounds involving carboxylates were synthesized (Institute of General and Inorganic Chemistry, Moscow State University, Russia); complexes based on biometals were synthesized, molecular and crystal structures, as well as bioactivity were determined (Royal Institute of London, Great Britain); polymer-type coordination compounds of carboxylic acids were obtained (Engineering-Technical Institute, China);

In the world, the scientific researches of Imanakunov B.I., Sulaymankulov K.S., Tsivadze G.V., Tsintsadze G.V., Kharitonov Yu.A., B. Kol, M. Holt, Hamilton V.S., Kozlova I.A., Savinkin Ye.V. and others are dedicated to the synthesis and physicochemical analysis of complex compounds of 3d metals and paracetamol in solutions. Leading scientists of our country Parpiev N.A., Khodjaev O.F., Khakimov Kh.Kh., Ibragimov B.T., Sharipov Kh.T., Azizov T.A., Azizov M.A., Kadirova Sh.K., Kadirova Z.Ch., Ibragimov A.B., Ashurov J.M. and their students have synthesized a number of biologically active coordination compounds used in medicine and other fields of the national economy. The technology of obtaining complex compounds of various salts of metals with organic ligands was developed, the processes of formation of coordination compounds in solutions and solid phases were studied. The physicochemical properties of the synthesized compounds were analyzed. Despite the fact that there are many experimental materials for the study of complexes of metal salts with substances containing an amino group and a carboxyl group, the synthesis of mixed ligand metal complexes of zinc chloride with paracetamol and glycine amino acid from these 3d metal salts has not been studied in solution. In addition, there is no information about the coordination structure of compounds of this class.

**Research Methodology:** In the process of this work, a complex combination of paracetamol, which is considered to be a weak anti-inflammatory and pain-relieving drug widely used in medicine, was synthesized with zinc metal from biometals. The synthesis process was carried out as follows. Initially, solutions of paracetamol in ethyl alcohol were prepared and neutralized with caustic alkali in order to increase its reactivity. Then, the obtained potassium salt solution is mixed with a solution of  $ZnCl_2 \cdot 4H_2O$  crystalline hydrate salt taken in a ratio of 2:1. During the reaction in laboratory conditions, a solution of 1.0 mmol of  $ZnCl_2 \cdot 4H_2O$  salt dissolved in 10 ml of distilled water is added to a solution of 2.0 mmol of paracetamol potassium salt in 20 ml of ethyl alcohol. Then it was thoroughly mixed in a MS-H280-Pro magnetic mixer for 40 minutes at a temperature of 45-50°C [4,5]. At the next stage, a small amount of glycine solution of neutral amino acid was added to the prepared mixture, and it was thoroughly mixed again in a magnetic mixer for 20 minutes at a temperature of 40°C. This mixture is left to evaporate slowly. As a result, a new complex compound of paracetamol was obtained and monocrystals were grown [6]. The obtained single crystal was washed in dimethylformamide and purified. Then its parameters were taken in the X-ray diffractometer in the form of a *cif* file, and its parameters were determined using Mercury and Plato programs. The image of this obtained single crystal is as follows.



**Figure 1. Illustration of the complex compound  $[Zn(L_1)_2(Gli)_2] \cdot 2H_2O$**

**Analysis and results:** The amount of metal in the synthesized complex was determined on the Novaa 300 apparatus of Analytic Jena (Germany), and the analysis of carbon, hydrogen and nitrogen elements was determined on the “EA 1108” apparatus of Carlo-Erba (Italy) (Table 1) [7]. The IR spectra of the compound were obtained, in the area of  $400-4000\text{ cm}^{-1}$  by IRAffinity-1S spectrophotometer of the firm Shimadzu (Japan) samples were prepared with KBr tablets with a diameter of 7 mm. X-ray structural analysis was obtained on an Xcalibur Roxford Diffraction automatic diffractometer at a temperature of 293 K (Cu K $\alpha$  radiation,  $k = 1.54184\text{ \AA}$ , xscan mode, graphite monochromator) [8].

**Table 1**  
**Results of elemental analysis of a complex of zinc chloride with glycine and paracetamol**

Compound	Zn %		C, %		H, %		N, %	
	Found	Calculated	Found	Calculated	Found	Calculated	Found	Calculated
$[Zn(L_1)_2(Gli)_2] \cdot 2H_2O$	10,28	11,67	41,81	42,54	5,05	5,16	12,2	12,6

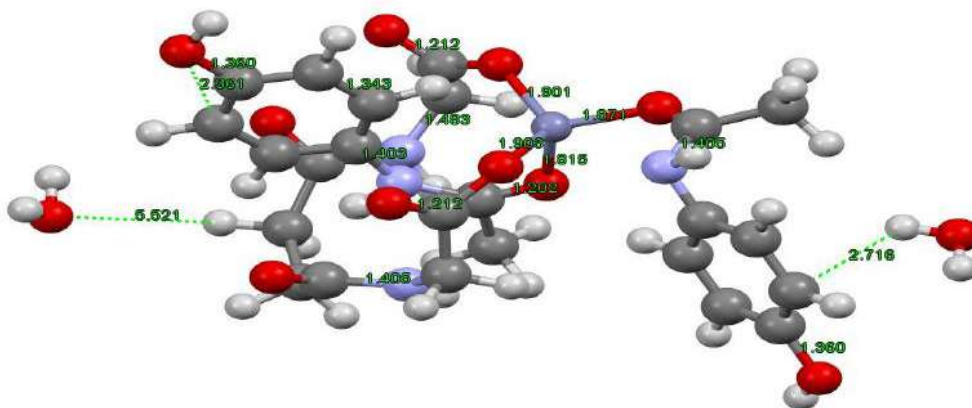
**Table 2**  
**Crystallographic data of the synthesized complex compound**

Parameter	Values	Parameter	Values
$[Zn(L_1)_2(Gli)_2] \cdot 2H_2O$			
Formula	$C_{24} H_{28} N_4 O_{10} Zn, 2(H_2O)$	Crystal size, mm	$0,2 \times 0,3 \times 0,32$
Molecular mass	633.93	Temperature T, °K	293(2)
Syngonia	Triclinic	Scan interval $\theta$ , °	2,14; -24,00
Spatial group	A1	Interval etc	-4:6; -8:8; -16:15
a, Å	15.1108(8)	Total reflexes	4330
b, Å	21.4320(13)	The number of independent reflexes	972
c, Å	21.4320(3)	$R_{int}$	0.046
$\alpha$ °	81.783(16)	$F2 \geq 2\sigma(F2)$ criterion	884
$\beta$ °	86.401(14)	Defined parameters	148

$\gamma^\circ$	76.367(15)	Quality of structure detection	1.08
$V, \text{\AA}^3$	6965.810	$R_1, wR_2 (I > 2\sigma(I))$	0.0648, 0.1535, 0.97
$Z$	2	$\Delta\rho_{\text{min/max}}, e\text{\AA}^{-3}$	0.40, 0.49
$D_x, \text{g/cm}^3$	0.302	CCDC-number and ref-code	
$\mu(\text{CuK}\alpha), \text{mm}^{-1}$	0.190		

**Table 3**
**Bond lengths and bond angles of a complex compound**

Bond	$d, \text{\AA}$	Angle	$\omega, \text{degree}$
Zn(1)-O(1)	1.8707	O(1)-Zn(1)-O(2)	110.85
Zn(1)-O(2)	1.9012	O(1)-Zn(1)-O(3)	112.12
Zn(1)-O(3)	1.9025	O(1)-Zn(1)-O(4)	110.71
Zn(1)-O(4)	1.8153	O(2)-Zn(1)-O(3)	122.09
O(1)-C(10)	1.2113	O(2)-Zn(1)-O(4)	98.84
O(2)-C(1)	1.3910	O(3)-Zn(1)-O(4)	100.33
O(3)-C(2)	1.3911	Zn(1)-O(1)-C(10)	123.90
O(4)-C(9)	1.2023	Zn(1)-O(2)-C(1)	131.59
O(5)-C(5)	1.2119	Zn(1)-O(3)-C(2)	132.38
O(6)-C(6)	1.2112	Zn(1)-O(4)-C(9)	115.65


**Figure 2. Interatomic bonding and bond length of the obtained complex compound  $[\text{Zn}(\text{L}_1)_2(\text{Gli})_2] \cdot 2\text{H}_2\text{O}$** 

The parameters of the elementary cell of the crystal are as follows: spatial group A1,  $a=15.1108(8)\text{\AA}$ ,  $b=21.4320(13)\text{\AA}$ ,  $c=21.4320(3)\text{\AA}$ ,  $\alpha=81.783(16)^\circ$ ,  $\beta=86.401(14)^\circ$ ,  $\gamma=76.367(15)^\circ$ ,  $V=6965.810(2)\text{\AA}^3$ ,  $Z=2$ .  $[\text{Zn}(\text{L}_1)_2(\text{Gli})_2] \cdot 2\text{H}_2\text{O}$  complex is mononuclear, formed by paracetamol and glycine molecules of  $\text{Zn}_2^+$  ion, neutral in nature. The value of the distance between Zn(1)-O(1), Zn(1)-O(2), Zn(1)-O(3), Zn(1)-O(4) bonds in the complex is equal to 1.8707 $\text{\AA}$ ., 1.9012 $\text{\AA}$ ., 1.9025 $\text{\AA}$ ., 1.8153 $\text{\AA}$  [9,10].

**Table 4**
**Hydrogen bonds in the crystal structure ( $\text{\AA}^\circ$ )**

Bond D-H...A	Distance, $\text{\AA}$			Angle D-H...A, degree.	Atomic coordinates, A
	D-H	H...A	D...A		
$[\text{Zn}(\text{L}_1)_2(\text{Gli})_2] \cdot 2\text{H}_2\text{O}$					



C(22)-H(16)...O(4)	1.10	2.58	3.658	166	$1/2+x, 1/2+y, 1/2+z$
C(16)-H(17)...O(2)	1.09	2.16	2.722	109	$-1/2+x, -1/2+y, z$
C(16)-H(17)...O(3)	1.09	2.20	2.707	106	$x, 1/2+y, 1/2+z$
C(12)-H(20)...O(6)	1.10	2.44	2.850	101	$x, 1/2+y, 1/2+z$

During the formation of a coordination compound, the glycine molecule in the compound is connected to the central zinc atom through the nitrogen atom of the amino group, and paracetamol is connected to the central zinc atom with the oxygen atom of the carbonyl group. Also, the central element zinc contains two more water molecules in the process of forming a complex compound. The difference in the distance between the zinc atom and the oxygen atom in glycine is explained by the Jan-Tellar effect. The central zinc atom in the complex compound is coordinated to form a triclinic molecule, and the size of the crystal is  $0.24 \times 0.16 \times 0.12$  [11,12]. The central zinc atom has a coordination number of 6 and is hybridized in the  $sp^3d^2$  state.

**Conclusion:** For the first time, a complex compound containing  $[Zn(L_1)_2(Gli)_2] \cdot 2H_2O$  was synthesized and its crystal structure was studied. The parameters of the unit cell of the single crystal of the complex compound are as follows: it was shown that the spatial group is  $A1$ ,  $a=15.1108(8)\text{\AA}$ ,  $b=21.4320(13)\text{\AA}$ ,  $c=21.4320(3)\text{\AA}$ ,  $\alpha=81.783(16)^\circ$ ,  $\beta=86.401(14)^\circ$ ,  $\gamma=76.367(15)^\circ$ ,  $V=6965.810(2)\text{\AA}^3$ ,  $Z=2$ . The coordination number of the central ion in this synthesized complex compound is equal to 6, and it is formed in an elongated octahedral form. The activity of the complex compound formed by the paracetamol molecule with zinc and glycine amino acid calculated from biogenic elements, more precisely, the range of action of paracetamol itself, was proved several times using physico-chemical analysis methods. The structural data (space structure and all crystallographic sizes) for this single crystal of the  $[Zn(L_1)_2(Gli)_2] \cdot 2H_2O$  coordination compound have been deposited in the Cambridge Crystallographic Structure Database for use in the synthesis of similar compounds.

#### References:

- [1]. Oxford Diffraction CrysAlis PRO CCD. Oxford Diffraction Ltd, Yarnton, England. -2009
- [2]. Sheldrick, G. M. Crystal structure refinement with SHELXL// Acta Cryst. 2015.–V. C71, P 3–8. doi:10.1107/S2053229614024218
- [3]. Ruzmetov A. Kh., Ibragimov A.B., Myachina O.V., Kim R.N., Ibragimov B.T. Synthesis, crystal structure, Hirshfeld surface analysis and bioactivity of the Cu mixed-ligand complex with 4-hydroxybenzoic acid and monoethanolamine // Chemical Data Collections. – 2022. – V.38. – p.100845.
- [4]. A.B. Ibragimov, Zh.M. Ashurov, A.B. Ibragimov. Synthesis and structure of a zinc complex with 3,5-dinitrobenzoic acid and ethylenediamine // Reports of the Academy of Sciences of the Republic of Uzbekistan, 2020, No. 1, pp. 45-50.
- [5]. Avazbek B. Ibragimov, Jamshid M. Ashurov, Aziz B. Ibragimov, Alisher G. Eshimbetov. Synthesis of the Three Mixed-ligand Metal Complexes and One Organic Salt of 3,5-Dinitrobenzoic Acid for Biopharmaceutical Optimization Through Monoethanolamine: Structures and DFT Studies of Complexes // Journal of Chemical





Crystallography, 2020, DOI 10.1007/s10870-020-00864-z.

- [6]. Khudoyberganov O.I., Ruzmetov A.X., Ibragimov A.B., Ashurov J.M., Khasanov Sh.B., Ibragimov B.T. Synthesis, crystal structure and Hirshfeld surface analysis of the binuclear Cu(II) complex with 4-nitrobenzoic acid and triethanolamine. *Chemical Data Collections*.100802. doi: 10.1016/j.cdc.2021.100802
- [7]. Fadeeva V. P., Tikhova V. D., and Nikulicheva O. N. Elemental Analysis of Organic Compounds with the Use of Automated CHNS Analyzers// *Journal of Analytical Chemistry*, 2008, -V.63(11), -P.1094–1106.
- [8]. Savitskaya L.K. X-ray structural analysis: textbook // Tomsk: SKK-Press, 2006, p.274.
- [9]. CrysAlisPro. Ver. 1.171.33.40, UK: Oxford Diffraction, 2007.
- [10]. Sheldrick G.M. // SHELXS97, SHELXL97, Programs for Crystal Structures Solution and Refinement, University of Göttingen, Göttingen, Germany. 1997.
- [11]. Macrae C.F, Bruno I.J, Chisholm J.A. et. al. Mercury CSD 2.0 – new features for the visualization and investigation of crystal structures // *J. Appl. Cryst.* - 2008. – V.41. -P.466-470.
- [12]. A. Ibragimov. Synthesis and structure of a mixed-ligand complex of zinc with 3,5-dinitrobenzoic acid and ethylenediamine // Republican scientific and scientific-theoretical conference on the topic "XXI century - the age of intellectual youth", April 24, 2020, Tashkent (Uzbekistan), pp .89 -90.

**UDC:547.564.4 +547.553.1**

**EVALUATION OF THE REACTION OF UREA WITH O-SUBSTITUTED AROMATIC AMINES USING QUANTUM CHEMICAL CALCULATIONS**

**Soporboev Zokir**

**Urgench State University,  
Master's student in Chemistry  
[soporboyevzokir@gmail.com](mailto:soporboyevzokir@gmail.com)**

**Eshchanov Khushnadbek  
Odilbekovich**

**Associate Professor of  
Urgench State University  
[xeshchanov77@gmail.com](mailto:xeshchanov77@gmail.com)**

**Dushamov Dilshod Azadovich  
Associate Professor of  
Urgench State University  
[dilshod.d71@mail.ru](mailto:dilshod.d71@mail.ru)**

**Annotatsiya:** Tadqiqotlarimizda o-almashgan aromatik aminlarning mochevina bilan reaksiyaga kirishish qobiliyatini GAMESS dasturining SPK-DZP basis to'plamida kvant kimyoviy hisoblashlar qilingan va eksperimental natijalar bilan taqqoslanib, aminlarning reaksiyaga kirish qobiliyati, mexanizmi va nisbiy faollik



qatori taklif qilingan. Reaksiya natijasida benzimidazolin-2-on, benzoksazolin-2-on, benzotiazolin-2-on sintezi amalga oshirilgan.

**Kalit soʻzlar:** o-aminofenol, o-aminotiofenol, o-fenilendiamin, benzimidazolin-2-on, benzoksazolin-2-on, benzotiazolin-2-on, mochevina, siklizatsiya.

**Аннотация:** В нашей работе проведены квантово-химические расчеты способности o-замещённых ароматических аминов реагировать с мочевиной в базовом наборе SPK-DZP расчетной программы GAMESS, и сопоставлены с экспериментальными результатами реакционной способности аминов, были предложены механизм и относительная активность. В результате реакции осуществлен синтез бензимидазолин-2-она, бензоксазолин-2-она и бензотиазолин-2-она.

**Ключевые слова:** o-аминофенол, o-аминотиофенол, o-фенилендиамин, бензимидазолин-2-он, бензоксазолин-2-он, бензотиазолин-2-он, мочеви́на, циклизация.

**Abstract:** In our research, quantum chemical calculations of the ability of o-substituted aromatic amines to react with urea were carried out in the SPK-DZP basis set of the GAMESS program, and compared with experimental results, the range of amines' reactivity, mechanism and relative activity was proposed. As a result of the reaction, synthesis of benzimidazolin-2-one, benzoxazolin-2-one, and benzothiazolin-2-one was carried out.

**Keywords:** o-aminophenol, o-aminothiophenol, o-phenylenediamine, benzimidazolin-2-one, benzoxazolin-2-one, benzothiazolin-2-one, urea, cyclization.

**Introduction.** Currently, there are many methods of synthesizing heterocyclic compounds, including the formation of compounds containing bonds such as carbon-nitrogen, carbon-oxygen, carbon-sulfur, and intramolecular cyclization reactions of aromatic and heterocyclic compounds using various reagents is important.

It is possible to cite practical studies on cyclization with the participation of various reagents, in particular, urea, thiourea and its derivatives, in obtaining nitrogen-containing heterocyclic compounds. Also, information on the use of cyclization reactions of o-substituted aromatic amines using various ureas as a starting material in the synthesis of five-membered heterocyclic compounds containing two heteroatoms condensed with a benzene ring - benzazoles and their derivatives [1-12].

The literature contains various information on the synthesis of benzoxazole and its derivatives, the main of which are the condensation reactions of o-substituted aromatic amines with carboxylic acids, their derivatives, as well as aldehydes and ketones [13-19].

As can be seen from the literature, reactions of o-substituted aromatic amines with various ureas were studied in the synthesis of benzazoles. However, they did not provide information on the cyclization of benzothiazolin-2-one, the reaction mechanism, and the relative activities of amines.

Therefore, we aim to provide suggestions on the reactivity of amines in the reactions of o-substituted aromatic amines (o-aminoaniline, o-aminophenol, o-aminothiophenol) with urea, the compatibility of practical results with theory, and the mechanism of reactions, and performed quantum chemical calculations.

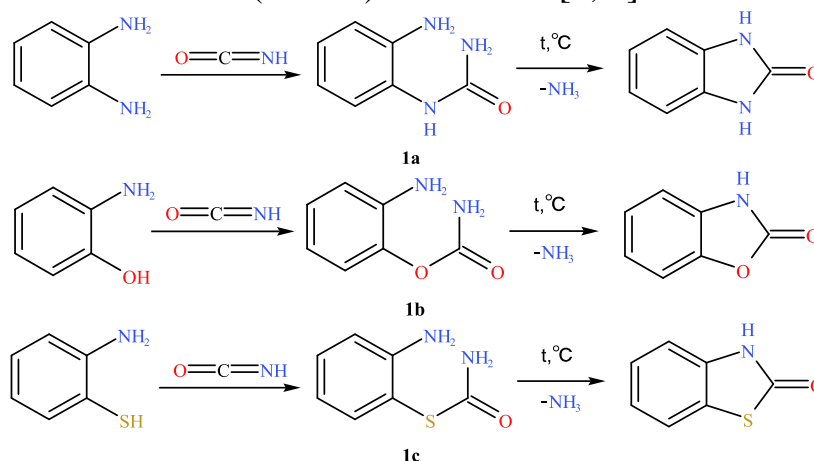
**Research methodology.** The GAMESS (USA) calculation program is widely used to perform quantum chemical calculations on many types of molecules. GAMESS (USA) can perform several general computational chemistry calculations, including the Hartree-Fock method, density functional theory (DFT), generalized valence bonding (GVB), and multiconfigurational self-consistent field (MCSCF). After these SCF calculations, correlation corrections can be estimated via configuration interaction (CI), second-order Møller-Plesset perturbation theory (MP2), and combined clustering. Relativistic corrections can also be calculated.

GAMESS (USA) also has a number of decomposition methods that allow the user to more conveniently calculate large molecular systems by breaking a large molecule into smaller, feasible parts.

Although the program does not perform molecular mechanics directly, it can perform mixed quantum mechanics and molecular mechanics calculations by interfacing with effective fragment potentials or the Tinker code. The fragment molecular orbital method can be used to apply large systems by dividing them into fragments.

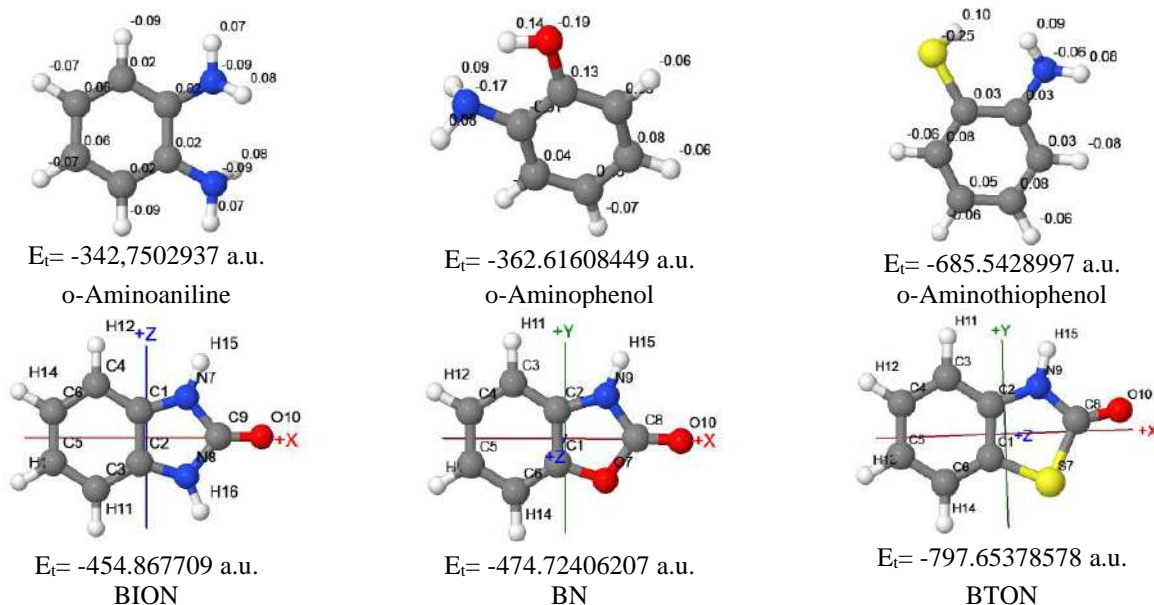
Taking into account the possibilities indicated above, in order to study the reactions between urea and o-substituted aromatic amines in-depth and to theoretically confirm the range of relative activity, to evaluate the causes of chemical reactions and the probabilities of the formation of the obtained substances' quantum chemical calculations were performed.

**Analysis and results.** It is known from the literature that the urea used in the synthesis process decomposes when heated at a high temperature, forming  $\text{NH}_3$  and HOCN acid [4]. At high temperatures, HOCN acid formed from the decomposition of urea reacts with o-substituted aromatic amines to form intermediate compounds **1a-c**. Compounds **1a-c** undergo an intermolecular condensation reaction at high temperature,  $\text{NH}_3$  is released and compounds benzimidazolin-2-one (BION), benzoxazolin-2-one (BN) and benzothiazolin-2-one (BTION) are formed [7, 8].



Quantum chemical calculations were performed on the starting materials used in the syntheses and the obtained products. Quantum chemical calculations were performed in the B3LYP exchange-correlation energy functional approximation class of DFT, the SPK-DZP basis set of the GAMESS (General Atomic and Molecular Electronic Structure System) calculation program developed by the Gordon research group at Iowa State University, USA [21, 22]. The total energies, charge distribution,

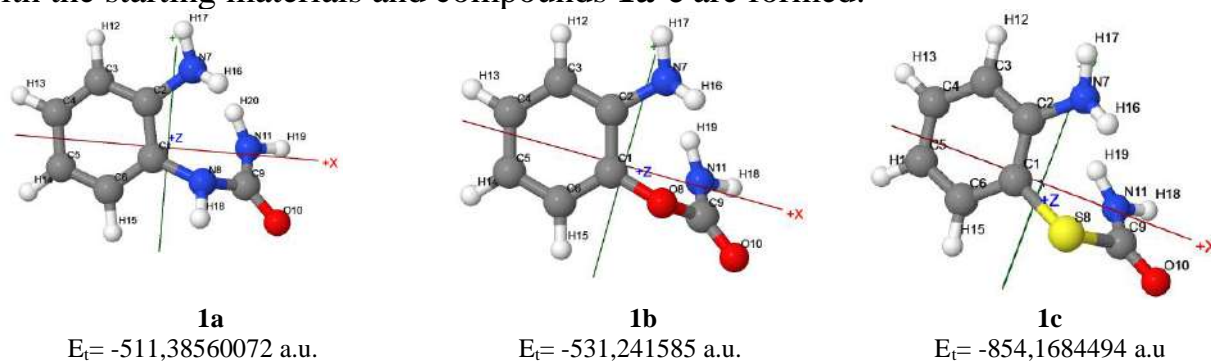
and potential field values of the molecules of the initial and formed substances were determined through calculations, and based on the obtained results, conclusions were made regarding the states of the reactive parts of the molecules during the reaction. In addition, thoughts were held about the probabilities of the creation of products. Below are the total energy values of the initial and synthetic molecules obtained in quantum chemical calculations (Figure 1).



**Figure 1.** The total energies of the molecules of the starting substances and the products obtained in the synthesis, determined by quantum chemical calculations

Based on the smallness of the total energy values of the products, the probability of forming all products can be considered energetically favorable. By studying the stability levels of chemical bonds in the functional groups involved in the chemical reaction and the distribution of the electron charge density in atoms, it helps in a certain sense to clarify the ideas about the mechanism of the process.

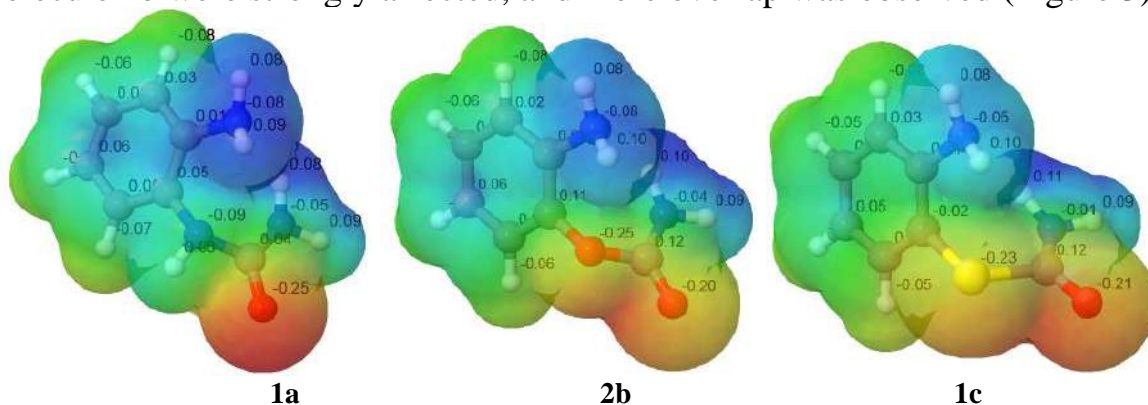
If we pay attention to the charge density distribution of the atoms in the functional groups  $-NH_2$ ,  $-OH$ ,  $-SH$ , participating in the reaction of the molecules of the initial substance, it can be seen that the charge densities of N, O and S atoms are equal to -0.09, -0.19 and -0.25, respectively. The fact that the electron density is greater in the S atom than in other atoms can increase the mobility of the H atoms. The higher the charge density of atoms, the more likely HOCN acid will interact with the functional group on which this atom is located. At the first stage of the reaction, HOCN acid reacts with the starting materials and compounds **1a-c** are formed.



**Figure 2.** Total energies of molecules of the intermediate substance formed in the process of synthesis

By determining the electron charge density of the atoms in the molecules of the intermediate substance, it is possible to think about which parts of the chemical changes will take place. It was found that the total energy values of the molecules of intermediate products are smaller than those of the target product molecules (Figure 2). This means that the spontaneous formation of BION, BN and BTON substances from intermediate products is not energetically favorable, and therefore additional energy must be supplied to the system for the process to proceed. Providing heat energy to the system ensures the reaction process.

Electrostatic potential field effects between atoms arise due to different electron densities of atoms in compounds. When the calculations were made of molecules of intermediate substances, the electrostatic potential fields between N7 and H19 atoms in molecule 1b were strongly affected, and more overlap was observed (Figure 3).



**Figure 3.** Electrostatic potential field of intermediate substance molecules

The C2-N7 bond is prevented from breaking due to strong electrostatic potential interaction between N7 and H19 atoms in 1b molecule. The conclusions obtained on the basis of the above quantum chemical calculations were fully confirmed by the results of the actual synthesis process. It was observed that the yield of the products obtained during the synthesis process was different (Table 1).

**Table 1.** Yields of products synthesized in the experiment

No	Name	Empirical formula	Yield
1	BION	$C_7H_6N_2O$	83 %
2	BN	$C_7H_5NO_2$	80 %
3	BTON	$C_7H_5NOS$	52 %

**Conclusion.** The agreement of practical indicators of the reactivity and the relative activity of amines in urea reactions with o-aminoaniline, o-aminophenol and o-aminothiophenol with the results obtained as a result of quantum chemical calculations (GAMESS) once again proves the reliability of the used calculation method. With the help of calculations, it was proved that the synthesis process creates intermediate substances and their decomposition to form BION, BN and BTON compounds. The use of the GAMESS calculation program in carrying out the synthesis of organic compounds or determining the reasons for the progress of the processes provides an opportunity to save excessive costs and time.



## References.

- [1]. Sharma, S., Bhattacharjee, D., & Das, P. (2018). Oxalic/Malonic acids as carbon building block for benzazoles, quinazoline and quinazolinones synthesis. *Organic & Biomolecular Chemistry*, 16(8), 1337-1342.
- [2]. Wen, X., El Bakali, J., Deprez-Poulain, R., & Deprez, B. (2012). Efficient propylphosphonic anhydride (@T3P) mediated synthesis of benzothiazoles, benzoxazoles and benzimidazoles. *Tetrahedron Letters*, 53(2012), 2440-2443.
- [3]. Бакибаев А.А., Яговкин А.Ю., Вострецов С.Н. (1998). Методы синтеза азотсодержащих гетероциклов с использованием мочевины и родственных соединений. *Успехи химии*, 67(4), 333–353.
- [4]. Яновский В.А., Батурин Д.М., Яговкин А.Ю., Бакибаев А.А. (2007). Реакции дифеновой кислоты с мочевиной как путь к ациклическим и циклическим амидам дифеновой кислоты. *Известия Томского политехнического университета*, 310(1), 52-157.
- [5]. Ключкова И.Н., Аниськов А.А., Воронов И.И., Французов А.А., Сазонов А.А. (2006). Реакции циклоконденсации карбонильных соединений с тиокарбамидами и родственными системами. *Известия Саратовского университета*, 6(1/2), 35-41.
- [6]. Карцева В.Г. (2003). Избранные методы синтеза и модификации гетероциклов. – М.: IBS PRESS, 1, 219-221.
- [7]. Пожарский А.Ф., Анисимова В.А., Цупак Е.Б. (1988). Практические работы по химии гетероциклов. Изд-во РГУ, Ростов – на – Дону, 77-79.
- [8]. Кнунынца И.Л. (1983). Реакции и методы исследования органических соединений. Под ред. акад. -М.: Химия, 78-80.
- [9]. Жукова Н. А., Мамедов В. А. (2017). Успехи в синтезе бензимидазол-2-онов. *Успехи химии*, 86(10), 968-997.
- [10]. Каток Я.М. (2020). Применение и синтез 2-замещенных бензимидазола. *Труды БГТУ*, 2(2), 50–55.
- [11]. Blokhin I.V., Mukhtorov L.G., Atroshchenko Y.M., Shakhkel'dyan I.V. (2018). Methods of synthesis of benzoxazoles. *Известия Тульского государственного университета. Естественные науки*, 3, 3-18.
- [12]. Сухинина Е.С., Другова Я.В., Нгуен Т.Т.Х., Трусова М.Е. (2015). Получение производных бензимидазола и бензоксазола. Сборник научных трудов IV Международной научно-технической конференции молодых ученых, аспирантов и студентов «Высокие технологии в современной науке и технике». – Томск: Изд-во Томского политехнического университета, 229-232.
- [13]. Sener E., Yalcin I., Temi O., Oren I. (1997). Synthesis and structure-activity relationships of some 2,5-disubstituted benzoxazoles and benzimidazoles as antimicrobial agents. *II Farmaco*, 52(2), 99-103.
- [14]. Temiz-Arpaci O., Aki-Sener E., Yalcin I., Altanlar N. (2002). Synthesis and Antimicrobial Activity of Some 2-[p-Substituted-phenyl] benzoxazol-5-yl-arylcarboxyamides. *Archiv der Pharmazie: An International Journal Pharmaceutical and Medicinal Chemistry*, 335(6), 283-288.
- [15]. Kumar R., Selvam C., Kaur G., Chakraborti A. K. (2005). Microwave-assisted direct synthesis of 2-substituted benzoxazoles from carboxylic acids under catalyst and solvent-free conditions. *Synlett*, 2005(09), 1401-1404.



- [16]. Pottorf R.S., et al. (2003). Parallel synthesis of benzoxazoles via microwave-assisted dielectric heating. *Tetrahedron letters*, 44(1), 175-178.
- [17]. Boissarie P.J., Hamilton Z.E., Lang S., Murphy J.A., Suckling C.J. (2011). A powerful palladium-catalyzed multicomponent process for the preparation of oxazolines and benzoxazoles. *Organic letters*, 13(23), 6256-6259.
- [18]. Mayo M.S., et al. (2014). Synthesis of benzoxazoles from 2-aminophenols and  $\beta$ -diketones using a combined catalyst of brønsted acid and copper iodide. *The Journal of organic chemistry*, 79(13), 6310-6314.
- [19]. Gorepatil P.B., Mane Y.D., Ingle V.S. (2013). Samarium (III) triflate as an efficient and reusable catalyst for facile synthesis of benzoxazoles and benzothiazoles in aqueous medium. *Synlett*, 24(17), 2241-2244.
- [20]. Черных В. П., Зименковский Б. С., Гриценко И. С. (2007). *Органическая химия*. -Х.: Изд-во НФаУ, 56-57.
- [21]. Perri, M. J. and Weber S. H. (2014). Web-Based Job Submission Interface for the GAMESS Computational Chemistry Program. *Journal of Chemical Education*, 91(12), 2206-2208.
- [22]. Barca, G. M. J., et al. (2020). Recent developments in the general atomic and molecular electronic structure system. *The Journal of Chemical Physics*, 152(15), 154102.

**UDC: 53.01/09**

## **EFFECT OF MAGNETIC FIELD ON VOLT-AMPERE CHARACTERISTICS OF P-N JUNCTION DIODES**

**Majidova Gulnoza Nurmuxamedovna**  
**PhD Namangan Engineering**  
**Construction Institute,**  
[majidovagulnoza@gmail.com](mailto:majidovagulnoza@gmail.com)

**Анотасија:** p-n o'tishli diodlarga turli tashqi ta'sir berilganda vol't –amper xarakteristikasining o'zgarishi solishtirilgan. Aynan magnit maydon ta'sirida diodda yuqori kuchlanishlarda tok kam bo'lish sababini tushuntirilgan. Maydon turli burchak ostida ta'sir ettirilsa p-n o'tish xajmiy soha kengligining yuzasi ortishi yoki kamayishiga kuzatilgan. Olingan natijalar tajribalar bilan solishtirilgan.

**Kalit so'zlar:** VAX-vol't –amper xarakteristika, diffuziya kuchi, Xoll kuchlanishi, magnit maydon, baza qarshilik, sirqish qarshilik, magnito qarshilik.

**Аннотация:** Сравняется изменение вольтамперных характеристик диодов с p-n переходом при различных внешних воздействиях. Объясняется причина малого тока при больших напряжениях на диоде именно под действием магнитного поля. Наблюдалось увеличение или уменьшение ширины площади объемного поля p-n перехода при воздействии магнитного поля под разными углами. Полученные результаты сравнивали с экспериментами.

**Ключевые слова:** ВАХ-вольтамперная характеристика, сила диффузии, напряжение Холла, магнитное поле, базовое сопротивление, сопротивление утечки, магнитосопротивление.

**Abstract:** The change in the current-voltage characteristics of diodes with a p-n junction is compared under various external influences. The reason for the low current at high voltages on the diode is explained precisely under the action of a magnetic field. An increase or decrease in the width of the volume field area of the p-n junction was observed when exposed to a magnetic field at different angles. The results obtained were compared with experiments.

**Key words:** current-voltage characteristic, diffusion force, Hall voltage, magnetic field, base resistance, leakage resistance, magnetoresistance.

**Introduction.** One can see the change in the width of the space charge when no magnetic field is applied to the pn junction diode. The reason is that in the absence of the action of the Lorentz force in the volume width of the charge, the electric field, and in the fields p and n depending on the equilibrium state of diffusion processes, there is an exchange with passing charge carriers until they are equal to the diffusion charge carriers under the action of the field (Fig. 1).

When a magnetic field is applied to a p-n junction diode, the electrons and holes bend perpendicular to the magnetic field and the direction of the current. The resulting Hall voltage radically changes the region of the space charge at the p-n junction of the diode. The thickness of the space charge and the height of the potential barrier of the p-n-junction remain variable in different areas of the cross-section of the p-n-junction. The height of the potential barrier of the p-n junction and the width of the space charge field are determined by solving the Poisson equation for current densities and electric field strength for electrons and holes in the diode [9].



Figure 1

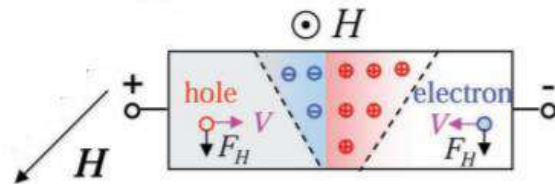


Figure 2

The change in the field width of the space charge in a diode with a p-n junction under the action of a magnetic field is schematically shown in fig. 2.

## II. CHANGE IN THE SHOCKLEY EXPRESSION AS A RESULT OF THE ACTION OF A MAGNETIC FIELD.

The effect of the Lorentz force causes a deflection in the n and p regions. As a result, the charges are displaced towards the edges of the sample. In this case, the field causes a sharp change in the transition resistance. An increase in resistance [1] results in a decrease in current. The height of the potential barrier increases.

$$j = j_n + j_p = en\mu_n E + eD_n \frac{dn}{dx} + en\mu_p E - eD_p \frac{dp}{dx} \quad (1)$$

When exposed to a magnetic field, the above formula will look like this:

$$\begin{aligned} qU_p p(x, y) \vec{E} - qD_p \nabla p(x, y) + qU_p p(x, y) (U_p \vec{E}) \times \vec{H} &= 0 \\ qU_n p(x, y) \vec{E} - qD_n \nabla p(x, y) + qU_n p(x, y) (U_n \vec{E}) \times \vec{H} &= 0 \\ \nabla \cdot \vec{E} = q(p(x, y) - n(x, y) + N_d - N_a) / \varepsilon & \quad (2) \quad [2] \end{aligned}$$



Accepting the condition  $j = 0$ , and comparing the forces acting on the p-n junction,

$F_e = enE_n S dx$  and diffusion forces  $F_d = kT \frac{dn}{dx} S dx$  we have the following expression.

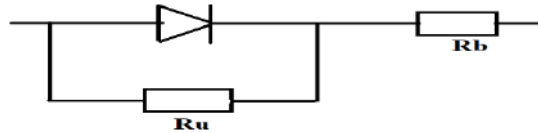
$$E_n = E_e + E_x \quad E_e = \frac{d\varphi}{dx} \quad E_x = aR_x J \beta$$

$$n_p = n_n e^{\frac{e}{kT}(\varphi + aR_x J \beta x)} \quad (3)$$

Using expression (3), we can express expression (1) as follows

$$j = j_s \left( e^{\frac{e\varphi_0}{kT} - \frac{e}{kT_e}(\varphi_0 - U - U_1 + aR_x J \beta x)} - 1 \right) \quad (4)$$

If we take a schematic view as follows

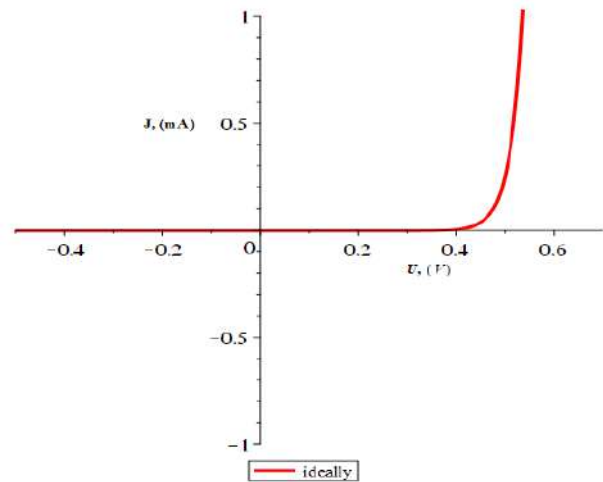
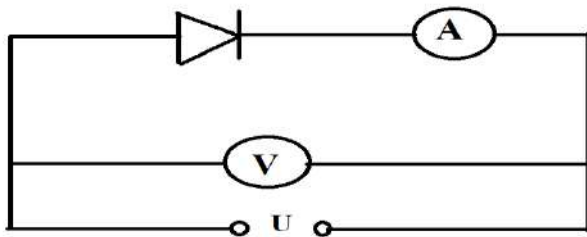


**Figure-3** is a schematic view of a diode versus base resistance and leakage resistance.

$$j = j_s \left( e^{\frac{e\varphi_0}{kT} - \frac{e}{kT_e}(\varphi_0 - U - U_1 + J(R_b + aR_x J \beta x))} - 1 \right) + \frac{U}{R_u} \quad (5)$$

Here:  $T$  is the phonon temperature,  $T_e$  is the temperature of the heated electron,  $R_b = R_b - AU^n$  - effective basic resistance,  $R_x$  - Hall constant,  $R_u$  - leakage resistance

If we compare the change in the CVC of an ideal diode as a result of various influences, we can observe the following.

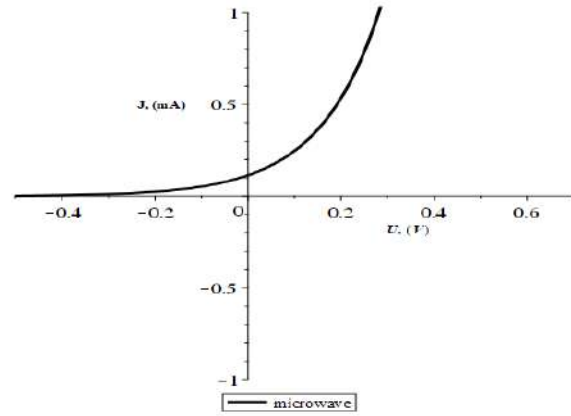
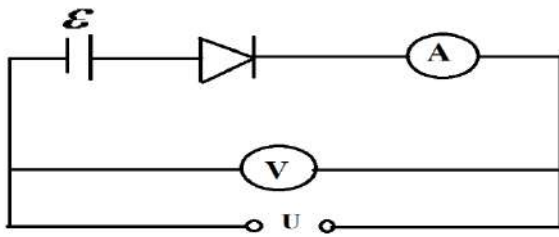


Schematic representation of a diode

Volt-ampere characteristic of the diode

**Figure 4.** Schematic representation of an ideal diode and current-voltage characteristics obtained based on the Shockley expression

If this diode is exposed to microwave, then both the schematic view and the current-voltage characteristic will look different [3-6].

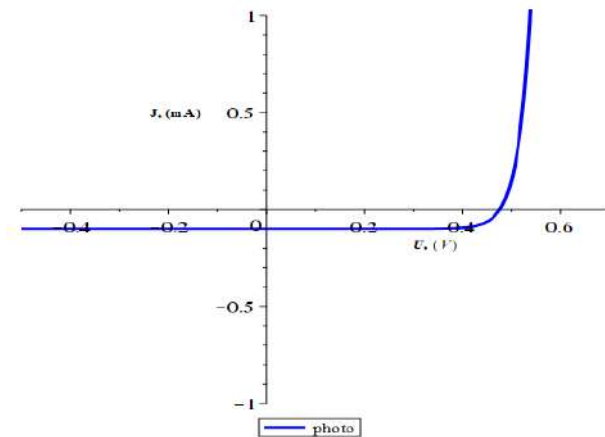
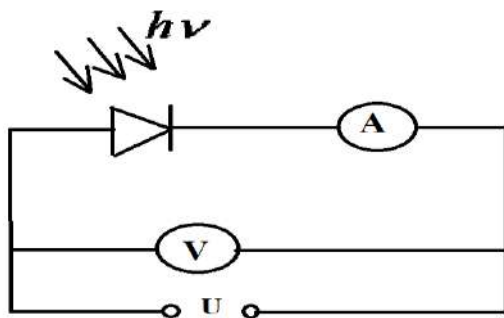


Schematic representation of a diode

Volt-ampere characteristic of the diode

**Figure -5** is a schematic view of a diode for the case when the diode is exposed to the microwave and current-voltage characteristics of the diode.

If the diode is exposed to light [7-9]

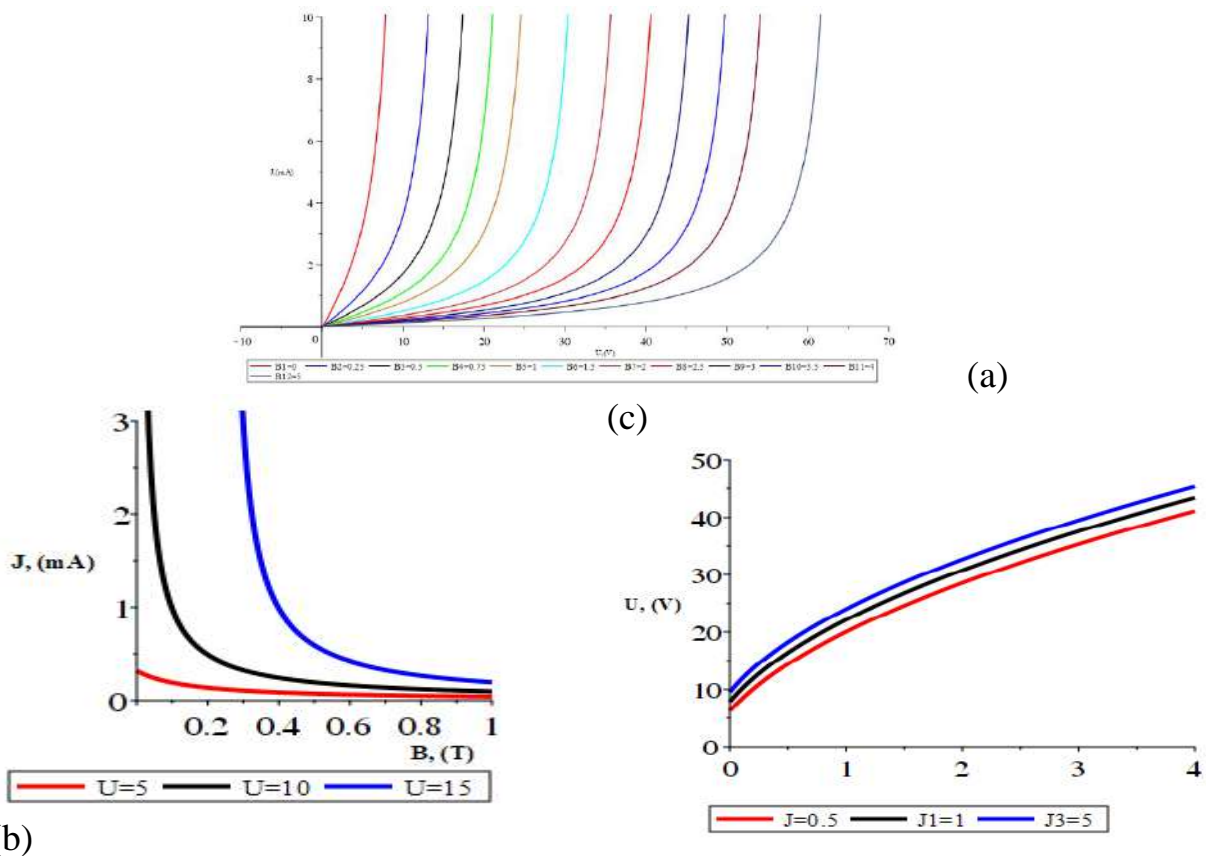


Schematic representation of a diode

Volt-ampere characteristic of the diode

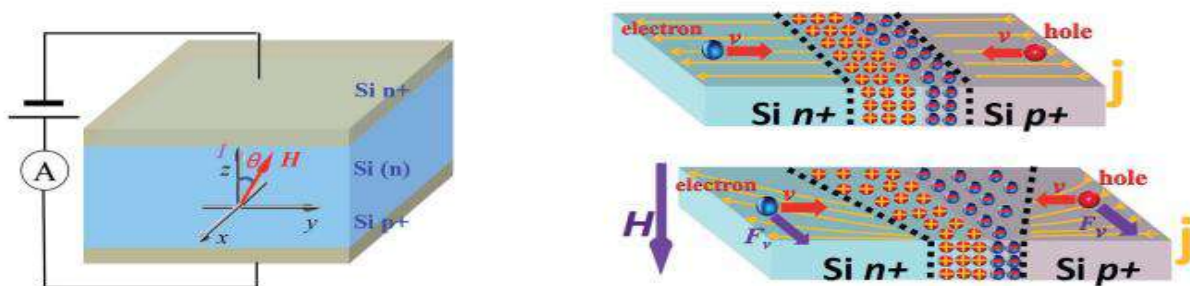
**Figure 6.** Schematic view of the state of the diode when exposed to light and the CVC of the diode.

Even when exposed to a magnetic field, a change in the CVC of the diode is observed. If you increase  $-B$  in a magnetic field, then the current-voltage characteristic of the diode is observed [6,7]. An increase in the magnetic field across the diode causes a decrease in the current flowing through it, even when a high voltage is applied to the diode. By changing  $-B$  in the aisles from 0 to 5 T according to expression (5), we obtain the CVC as follows. [10-14]



**Figure 6.** a) Change in CVC under the action of a magnetic field b) Dependence of  $J$  on  $V$  at various voltage values c) Dependence of  $U$  on  $V$  at various current values

### III. THE INFLUENCE OF A MAGNETIC FIELD AT DIFFERENT ANGLES ON THE I-V CHARACTERISTICS OF A P-N JUNCTION



**Figure 7.** Schematic representation of the p - n junction from the side of the magnetic field [16]

The magnetic field reduces short circuit currents. An increase in the magnetic field is equivalent to an increase in the resistance of the base  $R_0 + aB$ . An increase in the magnetic field is equivalent to an increase in the height of the potential barrier.  $\varphi_0 + a R_x JB \cdot \alpha$ . As a result of the combination of these two effects, it can be seen that the p-n junction diode has a giant anomalously large magnetic resistance, and the p<sup>+</sup> n, n<sup>+</sup> diode has a large anomalous magnetic resistance.

The component of the Lorentz force, perpendicular to the plane of the p-n junction, determines the height of the potential barrier.  $V = V_0 + V_1 \sin \alpha$ ,  $V = V_0 + V_1 f(\alpha)$

$f(\alpha)$  - angular function between the p-n junction plane and the drift velocity of charge carriers. Considering that the size of the diode is limited, the occurrence of eddy currents in the volume of the diode leads to the fact that the average value of the angular dependence of the Hall voltage is always positive and differs from 0.

$$V = V_0 + V_1 f(\alpha) ; V(j, \alpha) = V_0(j) + V_1(j) f(x) \quad (a)$$

The Hall voltage in the form of expression (a) is added to the height of the potential barrier and reduces the effective height of the potential barrier to the form  $\varphi = \varphi_0 + V(j, \alpha)$  [17].

Using the abnormally large magnetic resistance of a diode with a p-n junction, using a magnetic field, you can control the open voltage of the diode using a magnetic field, depending on the current strength and the dependence of the CVC on the magnetic field. on the face of the diode  $J = \int_{S(B)} j(B)x, y dx d = \int_{S(B)} j(B,S) dS$

The total current drives  $S$  through  $B$ , and the value of the current is strongly related to  $B$ . The Lorentz force tends to draw current at the open (potential current height minimum) surface in the diode cross section. The cross-sectional area of the current conductor reaches a minimum value along the p-n junction plane [18].

The cross-sectional area of the p-n junction current conductor decreases as the magnetic field increases.  $S_1 \succ S_{11} \succ S_3$  ( $a > b > c$ ) diode resistance  $R \sim \frac{a}{S}$  ;  $R = \rho \frac{1}{S}$   $S$  for

$$\text{p-n decreases with increasing } B. \quad \frac{R(B) - R(0)}{R(0)} \sim \frac{\frac{a}{S} - \frac{a}{S_0}}{\frac{a}{S_0}} = \frac{S_0}{S} - 1 \quad \frac{R - R_0}{R} \sim \frac{S_0}{S} - 1 ; S_0 \gg 1$$

$\frac{R - R_0}{R} \gg 1$ . This presents a gigantic large magnetic resistance.

**Conclusion.** As a result of the action of a magnetic field on a diode with a p-n junction, the current flowing through the bulk field decreases even when high voltages are applied. If we take into account that the space charge field of the p-n junction diode acts on the magnet at different angles due to the Lorentz force, then we can see that the cross-sectional area of the current conductor decreases with increasing magnetic field. The cross-sectional area of the current conductor has a minimum value along the p-n junction plane.

#### Acknowledgement

The work was performed on the basis of the Fundamental Research Grants  $\Phi 3$ -20200929243 "The Effect of Hot Electrons and Phonons in a Strong Electromagnetic Field on the Characteristics of Semiconductor Solar Photovoltaic Elements and Nanostructures"

#### References

- [1] V.L. Bonch-Bruevich, S.G. Kalashnikov "Physics of semiconductors", Nauka, M.1977.
- [2] B. G. Streetman, S. K. Banerjee, Solid State Electronic Devices, Prentice-Hall Inc, Upper Saddle River, NJ 2006, Ch.5.



- [3] G. Gulyamov, A. Gulyamov, B. Shahobiddinov & G. Majidova, “Changes in fermi quasi levels in silicon pn transitions under exposure to light and deformation and their influence on volt-ampere characteristics of diodes”. *Scientific and Technical Journal of Namangan Institute of Engineering and Technology*, 2020, 2(8), 10-19.
- [4] G.Gulyamov, A.G.Gulyamov. *Semiconductors*, 2015, vol.49, pp 819-822
- [5] S.H. Shamirzaev, G.Gulyamov, M.G.Dadamirzaev, A.G. Gulyamov. *Semiconductors*, 2011, v.45, №8, PP.1035-1037.
- [6] G.Gulyamov, G.N.Majidova, F. R. Muxitdinova & Madumarova, S “Changes in diodes with a p-n-transition under the influence of microwave radiation”, In *AIP Conference Proceedings 2023*, Vol. 2700, No. 1, p. 050008. AIP Publishing LLC March.
- [7] G.Gulyamov , B.B. SHaxobiddinov, G.N. Majidova, F.R. Muhiddinova “Yarimo`tkazgichli geteroo`tishlarni volt –amper xarakteristikasini tashqi ta`sirlarga sezgirligi ”, “Farg’ona poletexnika instituti Ilmiy –texnika jurnali ”, 2020. tom 24. № 2. Str.21-25.
- [8] G.Gulyamov , B.B. Shaxobiddinov, G.N. Majidova, F.R. Muhiddinova “Effects of a superhigh-frequency field on the photoelectric characteristics of p-n conductive semiconductor diodes” *Euroasian Journal of Semiconductors Science and Engineering*: Available at: <https://uzjournals.edu.uz>
- [9] Gulyamov, Gafur, Feruza Mukhitdinova, and Gulnoza Majidova. "Changing the Voltage of the p-n Junction in a Magnetic Field", *e-Journal of Surface Science and Nanotechnology* 2023/5/27.
- [10] Yang. D, Wang. F, Ren, Y., Zuo, Y., Peng, Y., Zhou, S., & Xue, D. “A Large Magnetoresistance Effect in p-n Junction Devices by the Space-Charge Effect”. *Advanced Functional Materials*, 23(23), 2918–2923, 2013
- [11] T. E. Park, B. C. Min, I. Kim, J. E. Yang , M. H. Jo , J. Chang , H. J. Choi , *Nano Lett.* 2011, 11, 4730. Acknowledgements This work is supported by National Basic Research Program of China (Grant No. 2012CB933101), the National Natural Science Foundation of China (Grand Nos. 50925103, 11034004, 11104122, 51201081). Received: September 17, 2012 Revised: November 20, 2012 Published online: February 6, 2013
- [12] G. Gulyamov, G.N. Majidova. "Influence of electron and phonon heating on the characteristics of solar photocells", *Romanian Journal of Physics* 68 (2023): 607.
- [13] N. A. Porte, C. H. Marrows, *J. Appl. Phys.* 2011, 109 , 07c703 .
- [14] Tao Wang, Mingsu Si, Dezheng Yang, Zhong Shi, Fangcong Wang, Zhaolong Yang, Shiming Zhou and Desheng Xue “Angular dependence of the magnetoresistance effect in a silicon based p–n junction device.” *Nanoscale*, 6(8), 3978–3983, 2014
- [15] B. T. Abdulazizov, G. Gulyamov, P. J. Baymatov, Sh.T. Inoyatov, M. S. Tokhirjonov and Kh. N. Juraev//Peculiarities of the Temperature Dependence of the Chemical Potential of a Two-dimensional Electron Gas in Magnetic Field// *SPIN* Vol. 12, No. 1 (2022) 2250002, World Scientific Publishing Company, doi:10.1142/S2010324722500023
- [16] M. M. Parish and P. B. Littlewood, *Nature*, 2003, 426, 162– 165.

**UDC: 53.04****A NEW MODEL FOR CALCULATING THE TOTAL CURRENT IN A TUNNEL DIODE**

**Uktamova Munira Komiljon qizi**  
**Namangan Engineering**  
**Construction Institute,**  
[\*\*umk9391@gmail.com\*\*](mailto:umk9391@gmail.com)

**Annotatsiya.** Ushbu maqolada o'ta yuqori chastotali maydon ta'sirida tunnel diodasida hosil bo'lgan umumiy tokni hisoblash uchun formula xisoblab chiqilgan. Bundan tashqari, tunnel diodining umumiy tokining o'ta yuqori chastotali maydon tomonidan induksiya qilingan umumiy quvvatga bog'liqligi nazariy jihatdan taqdim etiladi va eksperimental ma'lumotlar bilan taqqoslanadi. Tunnel diodidagi umumiy oqim uchun qo'shimcha tok hisobga olmagan holda, o'ta yuqori chastotali maydonning ta'siri bo'lgan va ta'sirisiz holatlar uchun oqim kuchlanish xususiyatlari olingan.

**Kalit so'zlar:** Chaynovet modeli, Tsu-Esaki modeli, o'ta yuqori chastotali maydon, potensial to'siqning shaffoflik koeffitsiyenti, qo'shimcha tok.

**Аннотация.** В данной работе выведена формула для расчета полного тока, генерируемого в туннельном диоде под действием СВЧ-поля и магнитного поля. Кроме того, теоретически представлена и сопоставлена с экспериментальными данными зависимость полного тока туннельного диода от полной мощности, наведенной СВЧ-полем. Для полного тока в туннельном диоде без учета избыточного тока были получены ВАХ для случаев с влиянием СВЧ-поля и без него.

**Ключевые слова:** модель Чайновета, модель Тсу-Эсаки, микроволновое поле, коэффициент прозрачности барьера, избыточный ток.

**Introduction.** The tunneling effect was experimentally discovered by Yajima and Esaki in a highly doped germanium-based diode [1-6]. A model was proposed by Leo Esaki in 1958 to explain this effect. In 1960, Evan O [7] developed a comprehensive theory of experience. Shortly thereafter, Karlovsky [8] proposed a simpler version of Esaki's model. In the Karlovsky model, the Fermi levels were sufficiently small. I. Shalish [9] and Kane, who worked independently, proposed the same model of the tunnel effect mechanism without knowing each other. In 1969, Duke presented a more advanced version of tunnel models [10]. As research on the properties of semiconductor materials and devices based on them continues, various tunneling models for p-n junction diodes have been presented. Since the electrical properties of semiconductor materials mainly depend on the state of impurity atoms in their volume, when choosing an alloying element, one should pay attention to their physicochemical parameters [11]. At a conference in Berlin in 1989, Herks presented a new model that related the rate of Shockley-Reed-Hall (SRH) recombination and zone-tunneling in the opposite direction [10]. In his work, Herks calculated the contribution of the tunneling effect as the recombination rate of the flux density. In the same direction, in 1991, Claassen [10] presented his model for the case of direct tunneling. The tunneling probability can also be calculated using the Wenzel-Kramers formula, but it is more convenient to calculate the tunneling probability using the transfer matrix method.

Currently, the calculation of the tunnel current for diodes with a p-n junction using the Tsu-Esaki model [15] gives good results. This model was developed taking into account the possibility of tunneling mentioned above. Today, scientists are proposing new models, as silicon-based diodes are used in many experimental works.

Tunnel diodes are widely used in the manufacture of various modern devices, such as nuclear weapons guiding installations, the creation of aerospace equipment, microwave ovens, etc. This indicates that the study of the properties of tunnel diodes and their wide application has great scientific and practical meaning. From the works presented above and from the available literature data, it can be seen that the effect of a magnetic field and an electromagnetic field with an ultrahigh frequency on a tunnel diode has not been studied enough. Based on this, the purpose of this work is to develop a new model for calculating the total current for a tunnel diode, taking into account the impact on the tunnel diode of a magnetic field and a microwave electromagnetic field [12–14].

## 2. Calculation of the total current generated in a tunnel diode under the action of microwave

According to the Tsu-Esaki theory, the direct current flowing through a tunnel diode is determined by the product of the  $N(E_X)$ -distribution function and the  $T_C(E_X)$ -transfer coefficient [10, 15]:

$$I_T = \frac{4\pi m_e f q}{\hbar^3} \int_{\min}^{\max} T_C(E_X) N(E_X) dE_X \quad (1)$$

The values of tunnel currents passing from region p to region n and from region n to region p are determined by the following expressions [15]:

$$I_{p \rightarrow n} = A \int_{\varepsilon_n}^{\varepsilon_p} f_p(\varepsilon) \rho_p(\varepsilon) P [1 - f_n(\varepsilon)] \rho_n(\varepsilon) d\varepsilon \quad (2)$$

$$I_{n \rightarrow p} = A \int_{\varepsilon_n}^{\varepsilon_p} P f_n(\varepsilon) \rho_n(\varepsilon) [1 - f_p(\varepsilon)] \rho_p(\varepsilon) d\varepsilon \quad (3)$$

The total tunnel current in the p-n junction is equal to the difference between expressions (2) and (3):

$$I = A \int_{\varepsilon_n}^{\varepsilon_p} \rho_p(\varepsilon) \rho_n(\varepsilon) P [f_n(\varepsilon) - f_p(\varepsilon)] d\varepsilon \quad (4)$$

The  $T_C(E_X)$ -transfer coefficient and  $N(E_X)$ -distribution functions can be specified as follows [16]:

$$N(E_X) = \int_0^{\infty} [f_n(\varepsilon) - f_p(\varepsilon)] dE_p \quad (5)$$

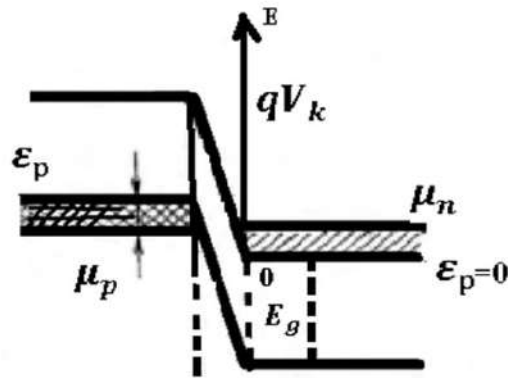
$$T_C(E_X) = \int P \rho_p(\varepsilon) \rho_n(\varepsilon) d\varepsilon \quad (6)$$

where  $\varepsilon_n$  and  $\varepsilon_p$  — are the minimum energy that electrons can accept in the conduction band of an n-semiconductor and the maximum energy that electrons can accept in the valence band of a p-semiconductor.

If we take the lower part of the conduction band as the beginning of the energy axis, that is, if we take  $\varepsilon_n = 0$  (Fig. 1), and, based on this figure, we have the following expression for the energy ( $\varepsilon_p$ ):

$$\varepsilon_p = qV_K - E_g = \mu_n + \mu_p \quad (7)$$

where  $\mu_n$  and  $\mu_p$  are the chemical potentials (Fermi level) for the regions n and p, respectively.



**Figure 1.** Scheme of forming the current-voltage characteristic of a tunnel diode

Also, when an external voltage is applied, we have:

$$\varepsilon_p = \mu_n + \mu_p - qV \quad (8)$$

And the distribution function is determined by the expressions:

$$f_n(\varepsilon) = \frac{1}{\exp\left(\frac{\varepsilon - \mu_n}{kT}\right) + 1} \quad (9)$$

$$f_p(\varepsilon) = \frac{1}{\exp\left(\frac{\varepsilon + \mu_p - qV_K + E_g + qV}{kT}\right) + 1} \quad (10)$$

The density of states of electrons and holes is  $\rho_n(\varepsilon) = C\sqrt{\varepsilon}$ ,  $\rho_p(\varepsilon) = C'\sqrt{qV_K - E_g - qV - \varepsilon}$ , where  $C$  and  $C'$  - are constant numbers. Taking into account the above, using expression (10), we obtain the following expression for the tunnel current [15]:

$$I_T = PTA \left( \int_0^{qV_K - E_g - qV} \left( \frac{1}{\exp\left(\frac{\varepsilon - \mu_n}{kT}\right) + 1} - \frac{1}{\exp\left(\frac{\varepsilon + \mu_p - qV_K + E_g + qV}{kT}\right) + 1} \right) \sqrt{\varepsilon(qV_K - E_g - qV - \varepsilon)} d\varepsilon \right) \quad (11)$$

Using expressions (9) and (10), finding  $qV_k$  and substituting expression (11), we obtain the following expression for the tunnel current:

$$I_t = APT \int_0^{\mu_n + \mu_p - qV} \sqrt{\varepsilon(\mu_n + \mu_p - \varepsilon - qV)} \left( \frac{1}{\exp\left(\frac{\varepsilon - \mu_n}{kT}\right) + 1} - \frac{1}{\exp\left(\frac{\varepsilon - \mu_n + qV}{kT}\right) + 1} \right) d\varepsilon \quad (12)$$

where:  $A = C'C \frac{4\pi m_{eff} q}{\hbar^3}$ . For the transparency coefficient, we use the following formula [10, 17]:

$$P = \exp\left(-\frac{\alpha E_g^{\frac{3}{2}}}{F}\right) \quad (13)$$

where: E-field strength,  $\alpha = \theta \frac{4\sqrt{2m_e}}{3q\hbar}$ ;  $\theta \approx 1$  ( $\theta$  is a constant parameter of the Chynoweth model). In many models [10, 17, 18], the barrier transparency coefficient was not taken into account, since  $E = \text{const}$ . Taking the value for the drift velocity of an electron at a p-n junction:

$$v = \mu E_x \quad (14)$$



(Where,  $m_{eff}$  is the mobility of the electron,  $E_x$  is the intensity of the microwave field), the expression of the power generated by the microwave field:

$$F = qE_x \quad (15)$$

as well as the value for the total power induced by the microwave field:

$$P_1 = F\vartheta \quad (16)$$

we have the following expression for the power under the action of a microwave field at a p-n tunnel junction:

$$\frac{P_1 - P_0}{N} = F\vartheta \quad (17)$$

where N is the number of electrons, is the difference between the total powers of the microwave field applied to the diode and the sample. If we generalize the above expressions, then the expression for the power spent on an electron under the action of a microwave field in a p-n tunnel junction can be written as follows.

$$\frac{P_1 - P_0}{N} = q\mu E_x^2 \quad (18)$$

from this expression we have the following formula for the  $E_x$ -strength of the field under action:

$$E_x = \sqrt{\frac{P_1 - P_0}{Nq\mu}} \quad (19)$$

And the expression for the transparency coefficient of the barrier under the action of the microwave field will have the form:

$$P = \exp\left(-\frac{\alpha E_g^{\frac{3}{2}}}{E + E_x}\right) = \exp\left(-\frac{\alpha E_g^{\frac{3}{2}}}{E + \sqrt{\frac{P_1 - P_0}{Nq\mu}}}\right) \quad (20)$$

The expression for the diffusion current for a heated electron is given by the following formula [19, 20]:

$$I_d = \left(I_0 \cdot \left(\frac{T}{T_0}\right)^3\right) \cdot \exp\left(\frac{E_g \cdot q}{k \cdot T_0} \left(1 - \frac{T_0}{T}\right)\right) \cdot \left(e^{\frac{q \cdot \phi}{k \cdot T} - \frac{q \cdot (\phi - V)}{k \cdot T_e}} - 1\right) \quad (21)$$

It is known that the total current I generated in a tunnel diode is the sum of the tunnel current,  $I_{Ch}$  excess current, and  $I_d$  diffusion currents in the tunnel diode [20].

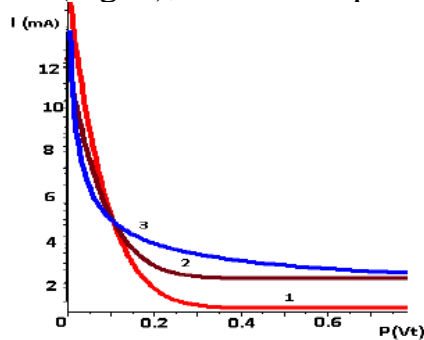
If the excess current in the tunnel diode is affected by the microwave field, then we have the following expression for volt-ampere characteristics:

$$I_{Ch} = DP = \int_{\mu_n + \mu_p}^0 \left( \sqrt{\varepsilon(\mu_n + \mu_p - \varepsilon - qV)} \left( \frac{1}{\exp\left(\frac{\varepsilon - \mu_n}{kT}\right) + 1} - \frac{1}{\exp\left(\frac{\varepsilon - \mu_n + qV}{kT}\right) + 1} \right) \right) d\varepsilon \times \exp\left(-\frac{\alpha E_g^{\frac{3}{2}}}{E + E_x}\right) \quad (22)$$

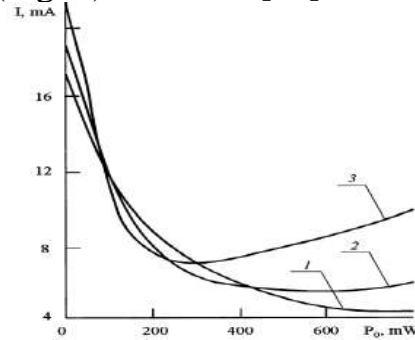
Here we have obtained the electric field strength as  $E_x = \frac{V_k - V + V_m}{d}$ , V - external voltage,  $V_k$  - contact potential difference, d - potential barrier width,  $V_m$  - voltage applied by the microwave field). Also, here we assumed that the density of states formed by impurities in the band gap in a p-n tunnel diode is constant. Now, summing all the current expressions, we obtain the following expression for the resulting total current for the tunnel diode:

$$\begin{aligned}
 I = & TA \exp\left(-\frac{\alpha E_g^{\frac{3}{2}}}{E + \sqrt{\frac{P_1 - P_0}{Nq\mu}}}\right) \times \\
 & \times \int_0^{\mu_n + \mu_p - qV} \left( \sqrt{\varepsilon(\mu_n + \mu_p - \varepsilon - qV)} \left( \frac{1}{\exp\left(\frac{\varepsilon - \mu_n}{kT}\right) + 1} - \frac{1}{\exp\left(\frac{\varepsilon - \mu_n + qV}{kT}\right) + 1} \right) \right) d\varepsilon + \\
 & + I_0 \left(\frac{T}{T_0}\right)^3 \exp\left(\frac{E_g q}{kT_0} \left(1 - \frac{T_0}{T}\right)\right) \left(\exp\left(\frac{q\phi}{kT} - \frac{q(\phi - V)}{kT_e}\right) - 1\right) \\
 & \int_{\mu_n + \mu_p}^0 \left( \sqrt{\varepsilon(\mu_n + \mu_p - \varepsilon - qV)} \left( \frac{1}{\exp\left(\frac{\varepsilon - \mu_n}{kT}\right) + 1} - \frac{1}{\exp\left(\frac{\varepsilon - \mu_n + qV}{kT}\right) + 1} \right) \right) d\varepsilon \exp\left(-\frac{\alpha E_g^{\frac{3}{2}}}{E + E_x}\right)
 \end{aligned}
 \tag{23}$$

Let us compare the graph of the dependence of the total current of the tunnel diode on the total power of the acting microwave field, calculated using the above theoretical expression (Fig. 2), with the experimental graph (Fig. 3) shown in [21].

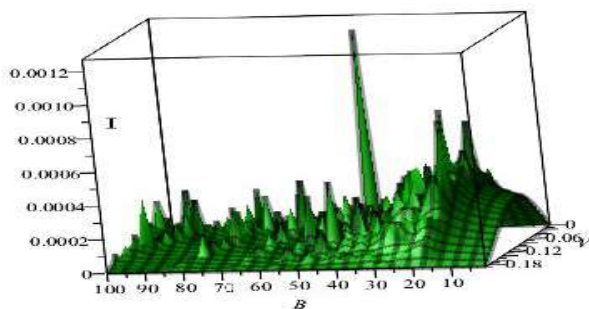


**Figure 2.** Graph of the dependence of the total current of the tunnel diode on the total power of the microwave field, calculated by expression (23).

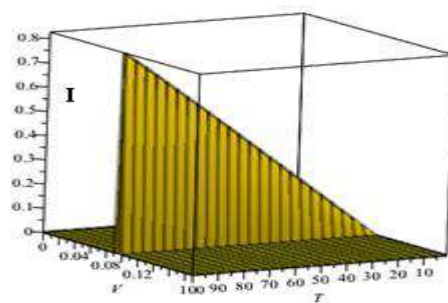


**Figure 3.** Graph of the dependence of the total current of the tunnel diode on the total power of the microwave field [21] (experimental result).

A three-dimensional spatial view of the CVC of the above tunnel diode under the action of a magnetic field is presented in two forms - in fig. 6 on the change in the magnetic field induction, in fig. 7 - by temperature change.



**Figure 4.** Three-dimensional view of the I-V characteristics of a tunnel diode



**Figure 5.** Three-dimensional spatial representation of the change in the I-V characteristics at different temperatures for a tunnel diode

**Conclusion.** An expression volt-ampere characteristics for the excess current of a tunnel diode under the action of a microwave field is obtained, as well as a formula for calculating the total current generated in a tunnel diode under the action of a microwave field and a magnetic field. In addition, the dependence of the total current of the tunnel diode on the total power induced by the microwave field is theoretically presented and compared with experiments in the available literature. For the total current in the tunnel diode, without taking into account the excess current, the volt-ampere characteristics were obtained for the affected and unaffected states, respectively.

### References

- [1]. K.P.Abdurakhmanov, Sh.B.Utamuradova, Kh.S.Daliev, S.G.Tadjy-Aglaeva and R.M.Ergashev, Semiconductors. **32(6)**, 606(1998). <https://doi.org/10.1134/1.1187448>
- [2]. Sh.B.Utamuradova, A.V.Stanchik, D.A.Rakhmanov, A.S.Doroshkevich and K.M.Fayzullaev, New Materials, Compounds and Applications. **6(3)**, 214(2022). [http://jomardpublishing.com/UploadFiles/Files/journals/NMCA/V6N3/Utamuradova\\_et\\_al.pdf](http://jomardpublishing.com/UploadFiles/Files/journals/NMCA/V6N3/Utamuradova_et_al.pdf)
- [3]. Sh.B.Utamuradova, Kh.S.Daliev, Sh.Kh.Daliev and K.M.Fayzullaev, Applied Physics. **6**, 90(2019). <https://applphys.orion-ir.ru/appl-19/19-6/PF-19-6-90.pdf>
- [4]. S.A.Muzafarova, Sh.B.Utamuradova, A.M.Abdugafurov, K.M.Fayzullaev, E.M.Naurzalieva and D.A. Rakhmanov, Applied Physics. **4**, 81(2021). <https://applphys.orion-ir.ru/appl-21/21-4/PF-21-4-81.pdf>
- [4]. Sh.B.Utamuradova, A.V.Stanchik, K.M.Fayzullaev, B.A.Bakirov, Applied Physics. **2**, 33(2022). [https://applphys.orion-ir.ru/appl-22/22-2/PF-22-2-33\\_EN.pdf](https://applphys.orion-ir.ru/appl-22/22-2/PF-22-2-33_EN.pdf)
- [5]. P.R.Berger, Comprehensive Semiconductor Science and Technology. 176(2011). <https://doi.org/10.1016/B978-0-44-453153-7.00013-4>
- [6]. O. Evan, Semiconductor Materials Department, Hughes Research Laboratories. **32**, 83(1961). <https://doi.org/10.1063/1.1735965>
- [7]. J.S. Karlovsky, Phys. Rev. **127**, 419(1962). <https://doi.org/10.1103/PhysRev.127.419>.
- [8]. I.Shalish, Journal of applied physics. **124**, 075102(2018). <https://aip.scitation.org/doi/10.1063/1.5038800>
- [9]. N.Moulin, A.Mohamed, F.Mandorlo and M.Lemiti, Journal of Applied Physics, American Institute of Physics. **126(3)**, 033105(2019). <https://doi.org/10.1063/1.5104314>
- [10]. N.A.Turgunov, E.H.Berkinov and D.X.Mamazhonova, Applied Physics. **3**, 40(2020). <https://applphys.orion-ir.ru/appl-20/20-3/PF-20-3-40.pdf>
- [11]. N.A.Turgunov, Inorganic Materials. **12(54)**, 1183(2018). <https://link.springer.com/article/10.1134/S0020168518120178>
- [12]. N.A.Turgunov, D.Kh.Mamajonova and E.Kh.Berkinov, Journal of nano- and electronic physics. **5(13)**, 05006-1(2021). [https://jnep.sumdu.edu.ua/download/numbers/2021/5/articles/jnep\\_13\\_5\\_05006.pdf](https://jnep.sumdu.edu.ua/download/numbers/2021/5/articles/jnep_13_5_05006.pdf)
- [13]. S.V. Syrotyuk, East. Eur. J. Phys. **4**, 31 (2021), <https://doi.org/10.26565/2312-4334-2021-4-03>



- [14]. S.M. Sze, Physics of Semiconductor Devices. John Wiley & Sons, Inc. **3**, 418(2007). <https://onlinelibrary.wiley.com/doi/pdf/10.1002/9780470068328.fmatter>
- [15]. T. A. Growden, Zh. Weidong, E. R. Brown, D. F. Storm, K. Hansen, P. Fakhimi, D. J. Meyer and P. R. Berger, Applied physics letters, **112**, 033508 (2018). <https://doi.org/10.1063/1.5010794>
- [16]. G.Gulyamov, M.G.Dadamirzaev and M.K.Uktamova, Guangdianzi Jiguang/Journal of Optoelectronics Laser. **9(41)**, 419(2022). <http://gdzjg.org/index.php/JOL/article/view/1144>
- [17]. A.G.Chynoweth, W.L.Feldman and R.A.Logan, Phys. Rev. **121**, 684(1961). <https://doi.org/10.1103/PhysRev.121.684>
- [18]. M.K.Uktamova and Sh.Nazarov, Web of scientist: International scientific research journal. **10(3)**, 800(2022). <https://wos.academiascience.org/index.php/wos/article/view/2601/2475>
- [19]. G.Gulyamov, M.G.Dadamirzaev, M.K.Uktamova and B.Z.Mislidinov, AIP Conference Proceedings. **2700**, 050007(2023). <https://aip.scitation.org/doi/abs/10.1063/5.0126516>
- [20]. I.K.Kamilov, K.M.Aliev, Kh.O.Ibragimov and N.S.Abakarova, J. Phys. Condens. Matter. **148**, 171(2008). <https://doi.org/10.1016/j.ssc.2008.06.017>

**UDK: 63:631.51**

**AGRICULTURE IS A PRIORITY SECTOR OF THE NATIONAL ECONOMY: PROBLEMS AND SOLUTIONS.**

**Khidiraliyev Komil Esanovich**  
Associate Professor of the  
Department of Ecology and Geography  
Candidate of Geographical Sciences  
Gulistan State University  
Faculty of Natural Sciences.

**Madrakhimova Zulfiya Nurmatovna**  
Head teacher at the Department of  
Ecology and Geography  
[madrakhimovaz@gmail.com](mailto:madrakhimovaz@gmail.com)

**Annotasiya.** Ushbu maqolada Respublika qishloq xo‘jaligining milliy iqtisodiyotda tutgan o‘rni tahlil qilingan. Shuningdek, qishloq xo‘jaligida bugungi kunda amalga oshirilayotgan islohotlarga e‘tibor qaratilgan. O‘zbekiston respublikasi qishloq xo‘jaligini rivojlantirishning 2020-2030 yillarga mo‘ljallangan strategiyasi mazmunidan kelib chiqqan holda, tahliliy ma‘lumotlar o‘ranilgan. Qishloq xo‘jaligida erishilayotgan yutuqlar tahlili asosida, soha oldida turgan muammolar ko‘rsatib berilgan.

**Kalit so‘zlar:** Qishloq xo‘jaligi, islohot, soha, tarmoq, strategiya, aholi, suv- yer muammosi, viloyat.

**Аннотация.** В данной статье анализируется роль сельского хозяйства республики в национальной экономике. Также уделяется внимание реформам, реализуемым сегодня в сельском хозяйстве. На основании содержания

Стратегии развития сельского хозяйства Республики Узбекистан на 2020-2030 годы проанализированы аналитические данные. На основе анализа достижений сельского хозяйства обозначены проблемы, стоящие перед отраслью.

**Ключевые слова:** Сельское хозяйство, реформа, сфера, отрасль, стратегия, население, водно-земельная проблема, регион.

**Abstract:** This article analyzes the role of the republic's agriculture in the national economy. Attention is also paid to the reforms being implemented today in agriculture. Based on the content of the Agricultural Development Strategy of the Republic of Uzbekistan for 2020-2030, analytical data was analyzed. Based on an analysis of agricultural achievements, the problems facing the industry are identified.

**Key words:** Agriculture, reform, sphere, industry, strategy, population, water and land problem, region.

**Introduction.** Agriculture is the heart of the agro-industrial complex, an important sector of the country's economy. It is an irreplaceable source of food for the people of any country. The world's population is busy searching for new sources of food due to synthesis of fat, protein and carbohydrates on a synthetic basis. But these products cannot replace naturally grown agricultural products. In this context, the vital importance of agriculture is determined by the following [1]:

- this sector provides the population with food;
- agriculture provides the main mass of raw materials for the light and food industry, that is, the products of these sectors are also directly used to meet the needs of the population. By the way, 40 percent of all material costs in the republic's textile industry, 70 percent in the sugar industry, and about 80 percent in milk and oil products per unit of agricultural raw materials;
- agricultural production has an effective influence on the rate and level of development of the republic's heavy industry. As agriculture consumes a large amount of means of production, tractors, reclamation and agricultural machinery, chemical industry, especially, have an active influence on the production of mineral fertilizers;
- agriculture is of great importance as a field of labor resource mobilization (employment in agriculture, forestry and fishing is 23.7%);
- the role of agriculture in the country's economy is determined by the fact that it is an important source of savings necessary for solving national issues. About 30 percent of the added value created in the national economy of the country is created in this sector. 40-50 percent of the total foreign currency income is generated from the sale of agricultural products and goods processed from them.

As we know, agricultural production also has its own characteristics that differ from other sectors of the national economy:

- depends on the speed of development and change of land-water resources, flora and fauna, living organisms in the network;
- the main means of production in this sector is land resources;
- economic process of reproduction is closely connected with nature, product production is connected with biological cycle;
- dependence of production on soil and climate conditions;
- the use of water resources plays an important role in this network;
- working time and production period do not match.

By the way, the following system of laws operates in agriculture, like all sectors of the national economy:

- advanced reproduction;
- accumulation;
- the laws of price, demand and supply;
- increase in labor productivity and others [2].

**Research Methodology.** In the following years, the reform of our country's agriculture, in particular, the improvement of the state management system in the field, the wide introduction of market relations, the strengthening of the legal basis of relations between the entities that grow, process and sell agricultural products, attract investments to the sector, introduce resource-efficient technologies and agricultural products certain works are being carried out to provide manufacturers with modern equipment.

At the same time, the absence of a long-term strategy for the development of agriculture hinders the effective use of land and water resources, the widespread attraction of investments in the sector, the high income of producers and the increase of competitiveness of products.

Diversification of production, improvement of land and water relations, creation of a favorable agribusiness environment and high added value chain, support for the development of cooperative relations, wide introduction of market mechanisms, information and communication technologies in the field, as well as effective use of scientific achievements and personnel in order to increase its potential, "The Decree of the President of the Republic of Uzbekistan on the approval of the strategy for the development of agriculture of the Republic of Uzbekistan for 2020-2030 was issued (October 23, 2019, No. PF-5853) [3].

The following are defined as priorities for the implementation of this Strategy:

- ensuring the safety of food products and improving the consumption ration, developing and implementing the state policy of food safety, which provides for the cultivation of the required amount of food products;
- wide implementation of market principles in the purchase and sale of agricultural products, development of quality control infrastructure, promotion of exports, creation of a favorable agribusiness environment and value-added chain, which provides for the production of competitive, high-added-value agricultural and food products in the target international markets;
- introduction of mechanisms to reduce state participation and increase investment attractiveness in the field, which involves increasing the flow of private investment capital to support the modernization, diversification and sustainable growth of the agriculture and food industry;
- the rational use of natural resources and the improvement of the environment protection system, which includes the rational use of land and water resources, the forest fund;
- development of modern management systems, which envisages restructuring and further development of the structure of state administration in agriculture;

- increasing efficiency of state expenditures and gradual redistribution by developing network programs aimed at increasing labor productivity in farms, improving product quality, creating high added value;
- development of the system of science, education, information and consulting services, which provides for the use of effective forms of knowledge and information distribution integrated with the production of research, education and consulting services in agriculture;
- implementation of development programs of rural areas that provide support for balanced and sustainable development of rural areas;
- creating a transparent system of network statistics, which involves the introduction of reliable methods of collecting, analyzing and distributing statistical data through the widespread introduction of modern information technologies, etc [4].

**Analysis and results.** In fact, if we look within these directions, the rational use of natural resources and environmental protection attract a high level of attention here. Today, only 20.7% of the 20.2 million hectares of agricultural land is irrigated land. Over the past 15 years, irrigated land per capita has decreased by 24 percent (from 0.23 ha to 0.16 ha).

This situation occurred as a result of population growth, reduction of water supply and transfer of agricultural lands to other land fund categories. According to forecasts, the irrigated land area may decrease by 20-25% over the next 30 years. Inadequate security of land use rights hinders the improvement of farm management efficiency and limits the attraction of investments.

Currently, clear and transparent mechanisms for the distribution of land plots and the protection of the rights of land users have not been fully created. Also, the lack of provision for secondary lease of land plots prevents the transfer of agricultural land to relatively potential land users.

About 80 percent of the republic's water resources are formed at the expense of transboundary water bodies. This situation determines the importance of regional cooperation for sustainable management of water resources in Central Asia, particularly in the Republic of Uzbekistan. In the country, 70% of irrigation networks do not have anti-filtration coating, as a result, part of the water is lost in the process of delivery to the fields. Most of the existing irrigation infrastructure, pumping stations, are in use for more than 30-40 years and need reconstruction or overhaul [5].

Currently, only 1.7% of the irrigated land has drip irrigation. The situation is likely to be further complicated by the continued use of traditional irrigation methods due to agriculture's high dependence on irrigation, and the dramatic increase in droughts as a result of climate change.

According to the forecast of the World Resources Institute, by 2040, Uzbekistan will become one of the 33 countries with the highest water shortage. The reduction in productivity has serious negative consequences for food security and the balance of payments, which creates the need for sustainable management of water resources and the use of resource-efficient technologies in the cultivation of agricultural crops.

The lack of a mechanism for covering the costs of water supply for agricultural needs prevents the widespread implementation of water-saving technologies. The

introduction of new modern water legislation in line with the European Union Parliament's Water Directive (2000/60/EU) will ensure the development of the necessary regulatory legal framework for future water policy and the introduction of harmonized methods of water resources management.

Indeed, agriculture is a sector rich in additional opportunities. The prosperity of our markets and the well-being of our lives largely depend on it. After all, the land of our country is generous. Therefore, in the following years, great attention is being paid to the radical reform of the agrarian sector and its adjustment to market requirements. For example, the nearly 3-fold increase in government purchase prices made cotton and grain growing a profitable industry.

In addition, the transition to a completely new work structure in cotton farming, i.e. the cluster system, has fundamentally changed the attitude to work. It became possible to effectively organize and manage work. Economical methods of irrigation were also implemented in cotton fields. In 2023, as a result of the introduction of a new water-saving irrigation system on 25,000 hectares of cotton, the harvest was three times higher than in 2022. 1,100,000 hectares of abandoned land are being put back into use.

Today, agriculture accounts for 30% of the gross domestic product, but it is evident that what we are doing is not enough, and that there is great potential in front of us. A lot has been done in agriculture in recent years. In particular, clusters and cooperatives were established. Many initiatives on water conservation and land development have been started [6].

In particular, the issue of increasing the export potential of the sector and increasing the volume of production of value-added products is of particular importance. If we pay attention to the world experience, the following will attract our attention. For example, 1 hectare of land in Turkey produces 2,000 dollars worth of produce, 8,000 dollars in Egypt, and 12,000 dollars in Israel. In our country, this indicator does not exceed 300 dollars. Our products are unable to compete in the foreign market due to the fact that the supply of goods of a uniform standard has not been established.

The export volume in the agricultural sector in 2018 was 2.3 billion dollars. As a result of the implementation of the tasks defined in the strategy, it is planned to increase this figure to 20 billion dollars by 2030.

If we look at the reforms taking place within the regions, Syrdarya region is going through a unique process. That is, a government decision was made on measures for more effective use of agricultural arable land in Syrdarya region. In accordance with the decision, the Syrdarya regional government took the following measures to develop 19,238 hectares of unused agricultural land in the region:

-5852 hectares of land according to the decision of the Cabinet of Ministers "On optimization of land areas of farms and other agricultural enterprises and additional measures on effective use of agricultural arable land" in the process of optimization of land areas of farms and other agricultural enterprises, farms and other to agricultural enterprises;

-1259 hectares of land to the foreign enterprise "Indorama Agro" Limited Liability Company;

-461 hectares of land to business entities for the development of poultry and other industries;





-10,000 hectares of reserve land in the territory of Mirzaabad district was allocated to the joint-stock company "Uzbekistan Railways" for the cultivation of agricultural products.

**Conclusion.** In conclusion, it should be said that in the sustainable development of agriculture, special attention should be paid to the following in order to ensure the rational and effective use of natural resources and to protect the environment:

-development and implementation of acceptable agricultural and environmental practices;

-promoting environmentally and climate-safe practices in agriculture;

-By 2030, reducing the water consumption used for irrigation of one hectare by 20%;

-improvement of state support mechanisms for producers and buyers of local water-saving technologies;

-improvement of the cadastral system of accounting for agricultural lands;

-improvement of the water resources management system.

#### **References:**

[1]. A. Ismailov, O. Murtazaev Agricultural economy. Tashkent- "Finance"-2005.-424 pages.

[2]. Joraev F. "Organization of production in agricultural enterprises". T., "Istiqlal". 2004 year.

[3]. Decree of the President of the Republic of Uzbekistan "Strategy for the development of agriculture of the Republic of Uzbekistan for 2020-2030" No. PF-5853.

[4]. Z.Izzatullaev, H.Botirov What does greening of agriculture mean? [zarnews.uz/post/zarnews.uz/post/qishloq-xojaligini-...](http://zarnews.uz/post/zarnews.uz/post/qishloq-xojaligini-...)

[5]. Nurbekov A., Aksoy U., Mumindzhanov H., Shukurov A. Organic farming: Sostoyanie, praktika i perspektivy. Prodovolstvennaya and selskohozyaystvennaya organization OON (FAO). Tashkent, 2018.

[6]. Sarimsakov F.Kh. Organic agriculture in the world and Uzbekistan and its current state // Issue 2/2020 of the scientific and practical journal "Akhborotnoma" July 12, 2020.