



# ACTUAL PROBLEMS OF MODERN SCIENCE, EDUCATION AND TRAINING

**KHOREZMSCIENCE.UZ**





## CONTENTS

<b>Section 1. MODERN PROBLEMS OF TECHNICAL SCIENCES.....</b>	<b>4</b>
SHAKIROV SHUKHRAT MUSAEVICH /// INFLUENCE OF POWDER PRESSING SCHEME ON THE STRESS-STRAIN STATE OF BUSHING-TYPE PRESS BRIQUETTE.....	4
MARDONOV BAKHTIYOR TESHAYEVICH, SHAKULOV BEGMAMAT KURBANOVICH, FAYZIYEV OYBEK SIDIKOVICH, TANGATAROVA LAYLO ALIJON KIZI, QARSHIBOYEV SUNNATILLO RUSTAMBEKOVICH /// DEVELOPMENT AND IMPLEMENTATION OF A SPECIAL DISC MODULAR CUTTER FOR SHAPING THREADS TO TRAPEZOIDAL PROFILES ON INTERNAL SURFACES.....	13
SHAKIROV SHUKHRAT MUSAEVICH /// PROSPECTS FOR MANUFACTURING MODERN STRUCTURAL MATERIALS BASED ON IRON POWDER.....	18
IBRAGIMOVA GULSHAN RUSLANOVNA, MIRZABEKOVA UMIDA NISHANBAYEVNA, KULAHMETOV OYBEK POCHCHAHONOVICH /// DEVELOPMENT AND CURRENT STATE OF THE PASSENGER TRANSPORT SYSTEM IN RAIL TRANSPORT.....	24
SHAKIROV SHUKHRAT MUSAEVICH, KARIMOV SHOIR AKHRAROVICH /// DISTRIBUTION OF RESIDUAL POROSITY BY HEIGHT IN VARIOUS SCHEMES OF PRESSING BUSHINGS FROM POWDERS.....	29
SULTANOV SULAYMON SAFARBOY UGLI, ISMOILOV RAXMATJON ILKHOM UGLI, MIRZAYEV OTABEK TAXIR UGLI, QODIROV ISLOMBEK REYIMBERGAN UGLI, SHAKIROV SHUKHRAT MUSAEVICH, ALLABERGENOV BUNYOD FARKHODOVICH /// MICROSTRUCTURAL PROPERTIES OF COPPER-GRAPHITE COMPOSITES PREPARED BY COLD PRESSING METHOD.....	36
ASHUROV KHISRAV KHURSHID UGLI, KHAMROEV NURBEK NURILLOEVICH, YAKHSHIEV SHERALI NAMOZOVICH, TANGATAROVA LAYLO ALIJON KIZI /// ANALYSIS OF IDENTIFICATION METHODS OF NON-METALLIC INCLUSIONS IN STEEL GRADE 110G13L.....	44
<b>Section 2. ACTUAL PROBLEMS OF NATURAL SCIENCES.....</b>	<b>49</b>
ULASHOV SHERBEK MUKHIDDIN UGLI, IKHTIYAROVA GULNORA AKMALOVNA, AKHMEDOVA SABINA MANSUR KIZI /// STUDY OF THE THERMOGRAVIMETRIC PROPERTIES OF THE SCHIFF BASE BASED ON CHITOSAN APIS MELLIFERA WITH GLUTARALDEHYDE.....	49
IBRAGIMOV LAZIZBEK TOSHPULAT UGLI /// CREATION OF A WATER CADASTRE GEOPORTAL FOR THE KASHKADARYA REGION BASED ON GIS TECHNOLOGIES.....	54
ZINOVIIY BOGDANOVICH NOVITSKY /// CREATION OF DESERT AGROPHYTOCENOSES ON THE DRIED BOTTOM OF THE ARAL SEA.....	59
<b>Section 3. ACTUAL PROBLEMS OF HISTORY, PHILOSOPHY AND SOCIOLOGY.....</b>	<b>64</b>
BABAJANOVA NILUFAR ALISHEROVNA /// SOME REFLECTIONS ON THE STAGES OF URBANIZATION PROCESSES IN THE KHOREZM OASIS DURING ANCIENT AND EARLY MEDIEVAL PERIODS.....	64



<b>TURGANOV BAKHYT GURBANBAEVICH, ALLAMURATOV ANVAR ALISHER UGLI /// RAW MATERIAL SOURCES OF BRONZE AGE SOUTH ISLAND METALLURGY INDUSTRY.....</b>	<b>69</b>
<b>MASHARIPOVA KHUSNIBON FARXODOVNA /// THE DISTINCTIVE FEATURES OF KAMOLIDDIN BEHZAD’S AESTHETIC VIEWS.....</b>	<b>75</b>
<b>KARAYEV NIZAM ABDURAIMOVICH /// SOCIAL-PHILOSOPHICAL FOUNDATIONS OF MORAL CULTURE.....</b>	<b>80</b>
<b>MAKSUMOV KHAMZA VALIKHONOVICH /// THE ESSENCE OF THE CONCEPT OF VALUES A CONTENT.....</b>	<b>83</b>
<b>Section 4. MODERN PROBLEMS OF PHILOLOGY AND LINGUISTICS.....</b>	<b>88</b>
<b>JAMILA ERMETOVA, CHAROS MATCHANOVA SHAKIRJON KIZI /// THE COMPARATIVE STUDY OF THE CONCEPT OF “FRIENDSHIP” IN KOREAN AND UZBEK PROVERBS.....</b>	<b>88</b>
<b>MAMBETOVA ROZA BALTABAEVNA, JUMAMURATOVA RAMIZA ADILMURATOVNA /// THE CONCEPT OF “GOOD AND EVIL” IN RUSSIAN AND ENGLISH LANGUAGES: A COMPARATIVE ANALYSIS OF PAREMIOLOGY.....</b>	<b>94</b>
<b>MAQSUD SIDDIQOVICH SHARIPOV, IXTIYOR DAVLATYOROVICH AVEZMATOV /// CONTEXT-FREE GRAMMAR BASED PARSING ALGORITHM FOR SIMPLE SENTENCES IN THE UZBEK LANGUAGE.....</b>	<b>99</b>
<b>Section 5. MODERN PROBLEMS OF PEDAGOGY AND PSYCHOLOGY.....</b>	<b>106</b>
<b>ABDIMUROTOV OYBEK URALOVICH /// STAGES OF ORGANIZING STUDENTS’ INDEPENDENT EDUCATION IN GEOGRAPHY.....</b>	<b>106</b>
<b>RAKHMONOV SUNNATILLO MAVLONOVICH /// ETHICAL COMPETENCES AND THEIR PEDAGOGICAL ANALYSIS.....</b>	<b>111</b>
<b>NORBOYEV ZAFAR ABDUMUMINOVICH /// IN HIGHER EDUCATION NEXT GENERATION TEXTBOOKS AND THEIR REQUIREMENTS.....</b>	<b>116</b>



## MODERN PROBLEMS OF TECHNICAL SCIENCES

UDC: 62, 621, 669, 669.1

### INFLUENCE OF POWDER PRESSING SCHEME ON THE STRESS-STRAIN STATE OF BUSHING-TYPE PRESS BRIQUETTE

**Shakirov Shukhrat Musaevich**

Associate Professor (PhD), Tashkent  
State Technical University named after  
Islam Karimov  
[goldstar\\_1471@mail.ru](mailto:goldstar_1471@mail.ru)

**Annotatsiya.** Ushbu tadqiqot yuqori mexanik xossa va zichlikga ega bo'lgan kukun asosli materiallarni ishlab chiqarish uchun temir kukun asosli aralashmalarni presslash jarayonini o'rganadi. Matematik model tashqi ishqalanish ta'sirini hisobga olgan holda turli presslash sxemalarida kuchlanish taqsimoti, g'ovaklik va deformatsiyani tahlil qiladi. Yechim shuni ko'rsatadiki, bosish kinematikasi jarayon parametrlariga bog'liq, lekin yuklash yuzasi turiga bog'liq emas. Analitik natijalar tajribalar bilan mos keladi, bu bir tomonlama, ikki tomonlama va suzuvchi qolipli presslashda qatlam deformatsiyasining aniq shakllarini namoyish etadi. Topilmalar nuqsonlarni minimallashtirish va sanoat ilovalarida deyarli nazariy zichlikka erishish uchun kukunli metallurgiya jarayonlarini optimallashtirish bo'yicha tushunchalar beradi.

**Kalit so'zlar:** Kukun metallurgiyasi, presslash, press qolipi, bir tomonlama presslash, ikki tomonlama presslash, mandrel va novda qarshi presslash, press briketi, kuchlanish, deformatsiya, chegara sharoitlari, bosim, qoldiq g'ovaklik, kuchlanish.

**Аннотация.** В этом исследовании изучается уплотнение порошков на основе железа для получения высокоплотных компонентов с улучшенными механическими свойствами. Математическая модель анализирует распределение напряжений, пористость и деформацию при различных схемах прессования с учетом влияния внешнего трения. Решение показывает, что кинематика прессования зависит от параметров процесса, но не от типа поверхности нагрузки. Аналитические результаты согласуются с экспериментами, демонстрируя различные модели деформации слоев при одностороннем, двустороннем и плавающем прессовании. Результаты дают представление об оптимизации процессов порошковой металлургии для минимизации дефектов и достижения плотности, близкой к теоретической, в промышленных приложениях.

**Ключевые слова:** Порошковая металлургия, прессование, пресс-форма, одностороннее прессование, двухстороннее прессование, встречное прессование оправки и стержня, пресс-брикет, напряжение, деформация, граничные условия, давление, остаточная пористость, напряжение.

**Abstract.** This study investigates the compaction of iron-based powders to produce high-density components with enhanced mechanical properties. A mathematical model analyzes stress distribution, porosity, and deformation under

different pressing schemes, considering the influence of external friction. The solution reveals that pressing kinematics depend on process parameters but not on the loading surface type. Analytical results align with experiments, demonstrating distinct layer deformation patterns in one-sided, two-sided, and floating die pressing. The findings provide insights for optimizing powder metallurgy processes to minimize defects and achieve near-theoretical density in industrial applications.

**Keywords:** Powder metallurgy, pressing, press mold, single-sided pressing, double-sided pressing, counter-pressing of the mandrel and the rod, press briquette, stress, deformation, boundary conditions, pressure, residual porosity, stress.

## Introduction

The main trend in modern mechanical engineering is the creation of new machines and mechanisms with high operating parameters based on the production of parts and blanks that have the required level of physical, mechanical, technological, and consumer properties [1-3]. The main consumers of high-density blanks and parts are the automotive and mechanical engineering industries [4, 6].

In the context of rapidly deteriorating environmental conditions, depletion of raw materials, and constant growth of production and transportation costs, the problems of recycling waste from metallurgical and steel-rolling industries are becoming increasingly urgent. Millions of tons of metal-containing waste generated annually during the production of ferrous metals and alloys pollute the environment and also require significant costs for their storage [7]. Therefore, the collection, preparation, and use of this waste can significantly reduce their negative impact on nature and humans, as well as significantly increase the efficiency of metallurgical processes.

Currently, the consumer market for high-density products requires parts with a density close to the theoretical one; blanks with a density of 0.95...0.97. According to the International Powder Metallurgy Federation (MPIF), further growth in the volume of production of parts based on powder materials will be determined by the development of production of new science- and labor-intensive types of powder products (primarily high-density) and the introduction of new progressive technological processes. The range of blanks and parts obtained by molding and sintering from iron-based powders using traditional technologies is limited due to the impossibility of ensuring high mechanical properties of parts with a significant level of residual porosity and low quality of interparticle contacts [8].

The prospective growth of production has determined the industrial necessity of finding special methods for improving the range of mechanical properties of powder parts [9, 10].

Powder metallurgy methods, namely the processes of compacting powdered iron-containing materials, make it possible to obtain mechanical densely packed systems of a regulated structure, while it should be noted that at present the theory and practice of forming structures of theoretical density that have strong interparticle diffusion bonds with the formation of an effective juvenile contact are not sufficiently developed.

An analysis of the structure formation schemes of high-density products showed that the direct use of traditional deformation schemes causes the appearance of defects, mainly associated with the formation of re-pressing layered cracks, as well as limiting the technological capabilities in the manufacture of parts of a wide range of standard sizes with a high level of physical and mechanical properties [9, 10].

## Literature Review

In a recent study on the influence of technological factors in the process of compacting powder materials by the method of uniaxial static pressing in closed molds, various pressing equations are used. These equations, as a rule, are an approximation of experimentally obtained dependencies of some indicator of the quality of pressing (usually this is porosity, relative density, or strength) on the technological factor affecting it (usually - pressing pressure). Most of the pressing equations usually have certain similar shortcomings related to the impossibility of observing the boundary conditions, the need for experimental determination of constant coefficients, and difficulties in their physical interpretation. The difficulties in interpretation are related to the fact that in most of the proposed equations the parameters of the impact (pressure) and response (strength, density, volume, height) are included in absolute form with a dimension depending on the chosen system of units of measurement [11-13].

Nevertheless, having been found for a specific material, scheme and pressing conditions, some of these equations are widely and successfully applied in the practice of powder product production. The most applicable are considered to be the Berezhnoy equation [13, 14], derived by him on the basis of the Pokrovsky equation [16]; its generalized form, proposed by Kainarsky [17]; the logarithmic form of the Balshin equation [18, 19], which is a modified form of the Berezhnoy equation.

One of the promising scientific areas of research into the compaction processes of powder and composite materials is the mechanics of structurally inhomogeneous materials, which studies the behavior of the structural elements of a material at the macro-, micro- and mesoscale levels. The idea of a scale-structural hierarchy during deformation of materials was formulated in the works of V.E. Panin [20].

The development of methods for the effective solution of technological problems of pressure processing of composite materials still remains an area of scientific research. The combined application of modern approaches to the mechanics of structurally heterogeneous materials and engineering analysis tools expands the understanding of the processes occurring in the structural components of a composite material and their state during plastic deformation.

In the cold pressing of metal powders, the main characteristics of the pressed product are the average density, distribution of porosity, and stresses over the volume of the briquette. In this paper, some variants of schemes for determining these distributions are proposed, and the features of the kinematic field that occur with various schemes for pressing bushings are analyzed. The main relationships between the characteristics of the pressed product and the parameters of the pressing process are adopted by us in the form proposed earlier by the authors of this study [21].

## Research Methodology

A special feature of the obtained boundary value problem is the presence of the parameter  $\lambda$  in the boundary conditions, different values of which will correspond to different solutions of the problem posed in [21]. Direct substitution into the equations and boundary conditions shows that the system of functions:

$$\theta = \theta_{av}; \quad \sigma_z = p_{ax}(\theta_{av}); \quad \sigma_r = \sigma_\varphi = p_{lat}(\theta_{av}); \quad u_r = e_r = e_\varphi = e_{rz} = V_r = \tau_{rz} = 0; \\ V_z = \frac{\dot{h}}{h} z; \quad e = e_z = \frac{\dot{h}}{h} \quad (1)$$

where  $\dot{h}$  – is the speed of movement of the upper punch, and  $p_{ax}(\theta_{av})$  и  $p_{lat}(\theta_{av})$  – is the dependence of axial and lateral pressure on porosity, which is the solution to the problem at  $\lambda = 0$ .

This solution is unique and has a completely obvious mechanical meaning: when pressing bushings in conditions of the absence of external friction, a uniform distribution of porosity and stress is observed in the volume of the product. The same conclusion was made by G. A. Meerson based on other considerations.

Moving on to constructing a solution to the problem for nonzero, we note that, according to the available data, the parameter is small. Therefore, external friction, characterized by the value of this parameter, can be considered as a factor disturbing the homogeneous state, and the solution to the problem is presented in the form:

$$\sigma_{ij} = \sigma_{ij}^{(0)} + \lambda \sigma_{ij}^{(1)}; \quad e_{ij} = e_{ij}^{(0)} + \lambda e_{ij}^{(1)}; \quad \theta = \theta^{(0)} + \lambda \theta^{(1)}; \quad V_i = V_i^{(0)} + \lambda V_i^{(1)} \quad (2)$$

Quantities with index 0 describe a homogeneous stress-strain state that would occur in the absence of external friction. Analytical expressions for them are given by relations (1) at  $\theta^{(0)} = \theta_{av}$ .

The disturbance of a homogeneous field introduced by external friction is described by quantities with index (1), which must be determined. The equations for their determination are obtained by substituting expressions (2) into general relations and subsequent simplification based on the assumption of the smallness of the quantity  $\lambda$ .

Let us consider the case of a piecewise smooth loading surface. Here the following equalities hold:

$$\varphi(\sigma_{ij}, \theta) = 0, \quad \psi(\sigma_{ij}, \theta) = 0 \quad (3)$$

Let us substitute representation (2) into (3) and use the following relations for a homogeneous state:

$$\varphi(\sigma_{ij}^{(0)}, \theta^{(0)}) = \psi(\sigma_{ij}^{(0)}, \theta^{(0)}) \quad (4)$$

Then we get:

$$\left. \frac{\partial \varphi}{\partial \sigma_{ij}} \right|_{\substack{\sigma_{ij} = \sigma_{ij}^{(0)} \\ \theta = \theta^{(0)}}} \sigma_{ij}^{(1)} + \left. \frac{\partial \varphi}{\partial \theta} \right|_{\substack{\sigma_{ij} = \sigma_{ij}^{(0)} \\ \theta = \theta^{(0)}}} \theta^{(1)} = 0 \quad (5)$$

$$\left. \frac{\partial \psi}{\partial \sigma_{ij}} \right|_{\substack{\sigma_{ij} = \sigma_{ij}^{(0)} \\ \theta = \theta^{(0)}}} \sigma_{ij}^{(1)} + \left. \frac{\partial \psi}{\partial \theta} \right|_{\substack{\sigma_{ij} = \sigma_{ij}^{(0)} \\ \theta = \theta^{(0)}}} \theta^{(1)} = 0 \quad (6)$$

The relationship for the rates of deformation in the case of flow on the edge of a piecewise smooth surface, given in [1], we multiply equation (5) by  $\dot{\nu}$ , and equation (6) by  $\dot{\chi}$ , and add the results. Considering that in this case the equality holds:

$$e_{ij}^{(0)} = \left( \dot{\nu} \frac{\partial \varphi}{\partial \sigma_{ij}} + \dot{\chi} \frac{\partial \psi}{\partial \sigma_{ij}} \right) \Bigg|_{\substack{\sigma_{ij} = \sigma_{ij}^{(0)} \\ \theta = \theta^{(0)}}} \quad (7)$$

Finally get:

$$e_{ij}^{(0)} \sigma_{ij}^{(\prime)} + \left( \dot{\nu} \frac{\partial \varphi}{\partial \sigma_{ij}} + \dot{\chi} \frac{\partial \psi}{\partial \sigma_{ij}} \right) \Bigg|_{\substack{\sigma_{ij} = \sigma_{ij}^{(0)} \\ \theta = \theta^{(0)}}} \theta^{(\prime)} = 0 \quad (8)$$

The factor at  $\theta^{(\prime)}$  can be eliminated using a consequence of the relations  $\dot{\varphi} = 0$  and  $\dot{\psi} = 0$ :

$$e_{ij}^{(0)} \sigma_{ij}^{(0)} + \left( \dot{\nu} \frac{\partial \varphi}{\partial \sigma_{ij}} + \dot{\chi} \frac{\partial \psi}{\partial \sigma_{ij}} \right) \Bigg|_{\substack{\sigma_{ij} = \sigma_{ij}^{(0)} \\ \theta = \theta^{(0)}}} \dot{\theta}^{(0)} = 0 \quad (9)$$

where the dots above the symbols denote the operation of taking the total derivative. Considering equalities (8) and (9) as a system of linear homogeneous equations, we have:

$$\sigma_z^{(\prime)} = p'_{ax}(\theta_{av}) \theta^{(\prime)} \quad (10)$$

In the same way, with much less complicated calculations, this expression can be obtained from the equation for a smooth loading surface.

Using the homogeneity factor of zero degree stresses as functions of strain rates leads to the equality:

$$V_r^{(\prime)} = u_r^{(\prime)} = e_r^{(\prime)} = e_\varphi^{(\prime)} = 0 \quad (11)$$

Which has places in the entire volume of the product. Taking it into account, we can get:

$$\frac{\partial V_z^{(\prime)}}{\partial r} = -2 \frac{e^{(0)}}{P_{lat}(\theta_{av}) - P_{ax}(\theta_{av})} \tau_{rz}^{(\prime)} \quad (12)$$

Further simplification of the general system is associated with the assumption of the monotonicity of the loading process. Its consequence is the relationship:

$$V_z^{(\prime)} = \frac{\rho_{el}}{\rho_{av}} \frac{V_z^{(0)}}{u_z^{(0)}} u_z^{(\prime)} \quad (13)$$

Where  $\rho_{el}$  – is the initial density of the product, which is assumed to be uniformly distributed;  $\rho_{av}$  – is its average density at the current moment of deformation:

$$u_z^{(\prime)} = \frac{h - h_{el}}{h} z$$

$u_z^{(\prime)}$  – axial perturbed component of the displacement vector.

Substituting (13) into (12), we obtain:

$$\frac{\partial u_z^{(\prime)}}{\partial r} = - \frac{h - h_{el}}{h} \frac{\rho_{el}}{\rho_{av}} \frac{e^{(0)}}{P_{lat}(\theta_{av}) - P_{ax}(\theta_{av})} \tau_{rz}^{(\prime)} \quad (14)$$

Considering that, by virtue of (11), only the axial component of the displacement vector  $u_z$ , differs from zero, the condition for conservation of mass can be written as:

$$\frac{\partial u_z^{(\prime)}}{\partial r} = 1 - \frac{\rho_{el}}{\rho_{av}}$$



As a result of substituting into both parts of the representation (2), we obtain:

$$\frac{\partial u_z^{(1)}}{\partial r} = 1 - \frac{\theta^{(1)}}{1 - \theta_{el}} \quad (15)$$

In addition to equality (12), another consequence of relation (11) is the equation:

$$\sigma_r^{(1)} = \sigma_\varphi^{(1)} \quad (16)$$

with the help of which we arrive at the result:

$$\frac{\partial \sigma_r^{(1)}}{\partial r} + \frac{\partial \tau_{rz}^{(1)}}{\partial z} = 0, \quad (17)$$

Substituting relations (2) into conditions (9) – (12) statically [21] leads to the following boundary conditions for the disturbed components:

$$\tau_{rz}^{(1)} \Big|_{r=b} = -p_{la}(\theta_{av}) \text{sign}(z - z_b), \quad (18)$$

$$\tau_{rz}^{(1)} \Big|_{r=a} = p_{la}(\theta_{av}) \text{sign}(z - z_a), \quad (19)$$

$$\int_0^h \int_a^b r \theta^{(1)} dr dz = 0. \quad (20)$$

$$\tau_{rz}^{(1)} \Big|_{z=0} = \tau_{rz}^{(1)} \Big|_{z=h} = 0, \quad (21)$$

## Analysis and Results

A characteristic feature associated with the boundary value problem (10), (11), (13) - (21) obtained for the disturbed components of the stress-strain state is the independence of its solution from the type of loading surface, which is expressed by the absence of functions  $f$ ,  $\varphi$ ,  $\psi$  and their gradients in the indicated relations. This solution depends only on the type of functions  $P_{ax}(\theta_{av})$  and  $P_{lat}(\theta_{av})$  which must be determined.

The established property significantly simplifies the approach to solving the class of problems under consideration: instead of setting up a large number of very complex experiments to determine the loading surface, in order to construct a solution to the problem, it is sufficient to limit ourselves to information obtained only as a result of experiments on compression.

Another very important property of the resulting boundary value problem  $u_z^{(1)}$  is established as a result of eliminating the quantity from equations (14) and (15), and  $\sigma_z^{(1)}$  the quantity from equations (1) and (25) of the article [21]. In this case, we obtain the system of equations:

$$p'_{oc}(\theta_{cp}) \frac{\partial \theta^{(1)}}{\partial z} + \frac{\partial \tau_{rz}^{(1)}}{\partial r} + \frac{\tau_{rz}^{(1)}}{r} = 0 \quad (22)$$

$$\frac{\partial \theta^{(1)}}{\partial r} - \chi \frac{\partial \tau_{rz}^{(1)}}{\partial z} = 0 \quad (23)$$

where

$$\chi = -(\theta_{av} - \theta_{el}) \frac{1 - \theta_{av}}{1 - \theta_{el}} \frac{1}{P_{lat}(\theta_{av}) - P_{ax}(\theta_{av})}.$$

Since the value of  $\chi$  is positive, the system of equations (22), (23) belongs to the elliptic type. This property of the obtained equations determines the main difference of

the mechanical model under consideration from classical models of ideal-plastic media and the limit equilibrium model, which lead to hyperbolic equations. A boundary value problem with boundary conditions specified on a closed contour for hyperbolic equations is ill-posed. At the same time, for elliptic equations, such a problem, which is a Dirichlet problem, is well-posed.

The solution of system (22), (23), satisfying the boundary conditions (18)-(21), has the form:

$$\theta^{(j)} = \sum_{n=1}^{\infty} C_n(r) \cos\left(\pi n \frac{z}{h}\right); \quad \tau_{rz}^{(j)} = \sum_{n=1}^{\infty} D_n(r) \sin\left(\pi n \frac{z}{h}\right)$$

where

$$\begin{aligned} D_n(r) &= \Phi_1 I_1\left(\alpha \frac{\pi n}{h} r\right) + \Phi_2 K_1\left(\alpha \frac{\pi n}{h} r\right) \\ C_n(r) &= \frac{p}{p'_{ax}(\theta_{av})} \sqrt{\alpha} \left[ \Phi_1 I_0\left(\alpha \frac{\pi n}{h} r\right) - \Phi_2 K_0\left(\alpha \frac{\pi n}{h} r\right) \right] \\ \alpha &= \sqrt{\frac{\chi}{p'_{ax}(\theta_{av})}} \\ \Phi_1 &= \frac{K_1\left(\alpha \frac{\pi n}{h} b\right) D_n(a) - K_1\left(\alpha \frac{\pi n}{h} a\right) D_n(b)}{I_1\left(\alpha \frac{\pi n}{h} a\right) K_1\left(\alpha \frac{\pi n}{h} b\right) - I_1\left(\alpha \frac{\pi n}{h} b\right) K_1\left(\alpha \frac{\pi n}{h} a\right)} \\ \Phi_2 &= \frac{I_1\left(\alpha \frac{\pi n}{h} b\right) D_n(a) - I_1\left(\alpha \frac{\pi n}{h} a\right) D_n(b)}{I_1\left(\alpha \frac{\pi n}{h} b\right) K_1\left(\alpha \frac{\pi n}{h} a\right) - I_1\left(\alpha \frac{\pi n}{h} a\right) K_1\left(\alpha \frac{\pi n}{h} b\right)} \\ D_n(a) &= \frac{2}{\pi n} p_{\sigma}(\theta_{cp}) \left( \cos \pi n + 1 - 2 \cos\left(\pi n \frac{z_a}{h}\right) \right) \\ D_n(b) &= -\frac{2}{\pi n} p_{\sigma}(\theta_{cp}) \left( \cos \pi n + 1 - 2 \cos\left(\pi n \frac{z_b}{h}\right) \right) \end{aligned} \quad (24)$$

The analytically obtained solution for  $0^{(1)}$  is expressed through the functions  $D_n(r)$  and  $C_n(r)$ . The latter are expressed through  $D_n(a)$  and  $D_n(b)$  and, thus, depend on the parameters  $z_a$  and  $z_b$ . Since these parameters determine the laws of motion of the press elements, the obtained solution explicitly takes into account the pressing scheme.

Let us analyze some qualitative features of the displacement field from the point of view of the obtained results. To do this, we exclude the quantity  $\tau_{rz}^{(j)}$  from equations (14), (18), (19). Introducing the notation  $\beta = \chi p_{la}(\theta_{av})$ , we obtain:

$$\begin{aligned} \left. \frac{\partial u_z^{(j)}}{\partial r} \right|_{r=b} &= -\beta \text{sign}(z - z_b) \\ \left. \frac{\partial u_z^{(j)}}{\partial r} \right|_{r=b} &= -\beta \text{sign}(z - z_a) \end{aligned}$$

Due to the absence of a radial component of displacement, the derivative  $\partial u_z^{(0)} / \partial r$ , multiplied by the coefficient  $\lambda$ , is the tangent of the angle of inclination to the plane of the base of the layer, which was parallel to this plane before pressing. If this angle of inclination is designated by  $\varphi$ , then its boundary values will be determined by the relations:

$$\operatorname{tg} \varphi|_{r=b} = -\lambda \beta |\operatorname{sign}(z - z_b)|, \quad \operatorname{tg} \varphi|_{r=a} = \lambda \beta |\operatorname{sign}(z - z_a)| \quad (25)$$

Let us now determine what the angles of rotation of the layers will be at the inner and outer side surfaces of the product for different pressing schemes.

In the case of one-sided pressing ( $z_a = z_b = 0$ ), it follows from relations (25) that the angles of inclination of the outer and inner walls will be opposite in sign and the same over the entire height on each of the surfaces.

In the case of two-sided pressing  $z_a = z_b = h/2$ . The pattern of the layer slopes will be, as can be seen from (25), mirror-symmetrical relative to the plane passing through the middle of the height and perpendicular to it. On different sides of this plane, the layers will be located near the walls, as in the case of one-sided pressing of a bushing of height  $h/2$ .

Pressing with counter movement of the matrix and rod corresponds to the values  $z_a = 0$  and  $z_b = h$ . In this case, it follows from (25) that the angles of inclination at the opposite side surfaces are equal and do not change sign over the entire height of the bushing.

Pressing with a floating matrix and a fixed rod is characterized by the values  $z_a = 0$  and  $z_b = h/2$ . From (25) it follows that in this case, the layers at the surface of the fixed rod will be inclined as in one-sided pressing, and at the surface of the floating matrix as in two-sided pressing.

## Conclusion

The qualitative features of the kinematic field that have been determined are in agreement with the experimental data obtained in experiments with layer-by-layer filling of multi-colored powders. Based on the expression for  $u_z^{(0)}$ , it is possible to determine the explicit form of the relationship between the parameters  $z_a$  and  $z_b$  with the values of the displacements of the matrix and rod. Due to the considerations developed in the work [1], the points  $z_a$  and  $z_b$  are characterized by the absence of tangential stresses in them. Therefore, according to (25), no curvature of the layers occurs at these points, i.e., the additional vertical displacements caused by external friction at these points vanish. Thus, based on (11) and (12), we have:

$$\omega_2 = u_z|_{r=b, z=z_b} = \frac{\omega_1}{h} z_b; \quad \omega_3 = u_z|_{r=a, z=z_a} = \frac{\omega_1}{h} z_a, \quad (25)$$

where  $\omega_1$ ,  $\omega_2$ ,  $\omega_3$  are the displacements of the upper punch, outer die, and inner rod, respectively.

The solution of the boundary value problem of the cold pressing process does not depend on the type of loading surface. It is determined by the dependences of axial and lateral pressure on porosity. The tangential stress and additional porosity caused by external friction are the solution of the Dirichlet problem for a system of elliptic

equations. Each pressing scheme corresponds to its own character of bending of layers parallel to the base plane before pressing.

### References:

- [1] Yurlova N.A. "Smart materials and structures: fiction or reality?" *Bulletin of the Perm Scientific Center*, 2, 2013, pp. 33–48.
- [2] Polkin I.S., Nikitin I.S., Bugaro N.G. "Obtaining titanium parts with "Taylor" structure and properties," *Titan*. № 4(38), 2012, pp. 37–41.
- [3] Karimov Sh.A., Shakirov Sh.M., Makhkamov Zh. "Brake pads on an iron base," *III-International scientific and practical conference "Modern materials, equipment and technologies in mechanical engineering"* dedicated to the 20th anniversary of JSC "Uzavtosanoat," Andijan, April 19-21, 2016, pp. 275-277.
- [4] Ilyushchenko A.F., Syroezhko G.S., Zvonarev E.V., Savich V.V. "State of research and production of products by powder metallurgy methods in the Republic of Belarus," *New materials and technologies: powder metallurgy, composite materials and protective coatings, welding: 6th international scientific and technical conf.*, Minsk, April 6-7, Materials of reports. – Mn.: *Tonpik*, 2004, pp.16-19.
- [5] Soshina T.O. "New materials and technologies," a teaching aid for universities, St. Petersburg: *Lan*, 2023, p. 196.
- [6] "New Materials," Coll. of authors. under the scientific editorship of Yu. S. Karabasov. – M: *MISiS.2002*, p. 736.
- [7] Shakirov Sh.M., Khasanov G.Sh. "Obtaining pilot samples of composite metal-ceramic materials from mill scale," *Composite materials*, №2, 2006, pp. 37-40.
- [8] Vityaz P.A., Sheleg V.K., Ilyushchenko A.F., Savich V.V. "Powder metallurgy: current state and prospects," *Powder metallurgy*. № 27, 2004, pp. 5-29.
- [9] Savich V.V. "Powder Metallurgy of the 21st Century: Quo vadis?" (based on materials from the seminar of Höganäs AB, St. Petersburg, May 14-16, 2008), *Powder Metallurgy*. № 31, 2008, pp. 304-313.
- [10] Balshin M.Yu. "Powder metallurgy," M.: *Mashgiz*, 1948, p. 286.
- [11] Berezhnoy A.S. "On the relationship between pressing pressure and porosity of unfired refractory products," *Refractories*. № 3, 1947, pp. 124 – 130.
- [12] Kazakevich S.S. "On the dependence of the compaction of fireclay masses on pressure during semi-dry pressing," *Refractories*. № 7, 60, 1957, pp. 120 – 123.
- [13] Efashkin G.V., Chernykh V.A. "On the hyperbolic dependence of the strength of pressed products on the pressing pressure," *Structural carbon-graphite materials*. part. 1, 62, 1964, pp. 256 – 261.
- [15] Cooper A.R., Eaton L.E. "Compaction Behavior of Several Ceramic Powders," *J. Amer. Ceram. Soc.*, Vol. 45, № 3, 1962, pp. 97 – 101.
- [16] Balandin P.P. "On the issue of calculating the pressing process," *Refractories*. № 3, 1938, pp. 1081 – 1084.
- [17] Berezhnoy A.S. "The influence of pressing pressure on the properties of magnesite refractories," *Refractories*. № 4, 1954, pp. 213 – 222.
- [18] Kondrashev F.V. "In the collected works of the Research Institute of Construction Ceramics," *Gosstroyizdat*, Issue. 17, 61, 1961, pp. 60 – 71.
- [19] Sapozhnikov M.Ya., Bulavin I.A. "Machines and apparatuses of the silicate industry," Moscow: *Promstroyizdat*. Part 1. 1950.
- [20] Ivlev D.D. "Theory of Ideal Plasticity," Moscow: *Nauka*, 1966, p. 234.
- [21] Shukhrat Shokirov et al. "Development of boundary conditions for the construction of a mathematical model of the process of pressing powder in a closed mold", *Electronic journal of Actual problems of modern science, education and training*, April, 2024, pp. 4-16.





UDC: 62, 621, 669, 669.1

## DEVELOPMENT AND IMPLEMENTATION OF A SPECIAL DISC MODULAR CUTTER FOR SHAPING THREADS TO TRAPEZOIDAL PROFILES ON INTERNAL SURFACES

**Mardonov Bakhtiyor Teshayevich**

*Professor, Navoi State University of Mining and Technologies*  
[mbt69@mail.ru](mailto:mbt69@mail.ru)

**Shakulov Begmamat Kurbanovich**

*Engineer, Gidro Stanko Servis LLC*  
[begmamatshakulov@gmail.com](mailto:begmamatshakulov@gmail.com)

**Fayziyev Oybek Sidikovich**

*Engineer, Gidro Stanko Servis LLC*  
[oya\\_92@mail.ru](mailto:oya_92@mail.ru)

**Tangatarova Laylo Alijon Kizi**

*Master Student, Navoi State University of Mining and Technologies*  
[laylotangatarova9@gmail.com](mailto:laylotangatarova9@gmail.com)

**Qarshiboyev Sunnatillo Rustambekovich**

*Master Student, Navoi State University of Mining and Technologies*  
[sunnat901kh@gmail.com](mailto:sunnat901kh@gmail.com)

**Annotatsiya.** Maqolada “GIDRO STANKO SERVIS” MCHJ ishlab chiqarish bazasi sharoitida konstruksion po‘latlar va cho‘yandan tayyorlangan murakkab konfiguratsiyali korpus detallari teshiklarida trapetsiyasimon profillarda rezbalarni shakllantirish uchun maxsus diskli keskichni ishlab chiqish va joriy etish ko‘rib chiqilgan.

**Kalit so‘zlar:** Maxsus diskli modulli freza, rezba qirqish, konstruksion po‘lat, kulrang cho‘yan, ko‘p maqsadli dastgoh.

**Аннотация.** В статье рассмотрено разработка и внедрения специального дискового фрезы для формообразования резьбы профилям трапеции отверстиях корпусных деталей сложной конфигурации, изготовленных из конструкционных сталей и чугуна в условиях производственной базы ООО “GIDRO STANKO SERVIS.”

**Ключевые слова:** Специальная дисковая модульная фреза, нарезания резьбы, конструкционная сталь, серый чугун, многоцелевой станок.

**Abstract.** The article examines the development and implementation of a special disc cutter for shaping threads on trapezoidal profiles in holes of complex-configuration housing parts made of structural steels and cast iron under the conditions of the “GIDRO STANKO SERVIS” LLC production base.

**Keywords:** Special disc modular cutter, thread cutting, structural steel, gray cast iron, multi-purpose machine tool.

## Introduction

Developing a specialized tool for shaping threads with trapezoidal profiles on internal surfaces represents a significant innovation in the machining industry. Conventional threading methods often struggle with achieving high precision and consistent quality on internal surfaces. This project proposes the development of a modular disc cutter that can shape trapezoidal threads, which are commonly used in industries such as automotive, aerospace, and manufacturing for various internal thread applications.

## Literature Review

Currently, one of the most important priorities in metalworking is cost reduction.

On a global scale, the development of new methods of design and technological support for the accuracy of metalworking by cutting and shaping of threaded surfaces is one of the main ways to increase accuracy and productivity, simplify machining, and reduce machining costs.

It can be assumed that, to date, most of the shaping processes for machine parts and their combinations have been developed and implemented in practice. Its own equipment and tools of varying degrees of perfection have been developed.

In general, the shaping process does not satisfy the high level of modern machine-building production in terms of quality and productivity. A very close illustration of this is the current state of the technology for cutting threads of the trapezoidal shape profile into a hole, which has a significant impact on the weight of the technological route for manufacturing complex body parts.

Despite the numerous developed technologies for shaping threaded surfaces in mechanical engineering, it remains one of the most important problems in obtaining high precision.

One of the important aspects of the requirement for metal-cutting tools is the simplicity of construction, ease of operation, and low cost.

This time for shaping threads in the holes of complex housing parts of the trapezoidal profile remains a problem, existing methods of shaping threads with cutting tools do not allow for high-precision execution of this process. Intensive wear of the cutting edges occurs during thread cutting as a result of incorrect shaping with each sharpening of the cutting edges of the tool. It is necessary to adjust the machining modes on the machine, as a result of which errors in shaping the thread profile occur, as a result of which tool consumption increases and the cost of the process increases.

To solve this problem, we have developed a special tool - a modular cutter - for shaping threads with trapezoidal profiles in the holes of complex body parts [ 1, 3, 4].

The disc cutter consists of the following main parts: 1-cutter body, 2-cutting plate (see in Figure 1).

This cutting tool is used to form threads in the holes of complex housing parts of the trapezoidal profile on a multi-purpose machine. The part is installed on the machine's satellite table, and the special disc cutter in the mandrel is installed on the spindle, and it carries out the process of cutting threaded surfaces.

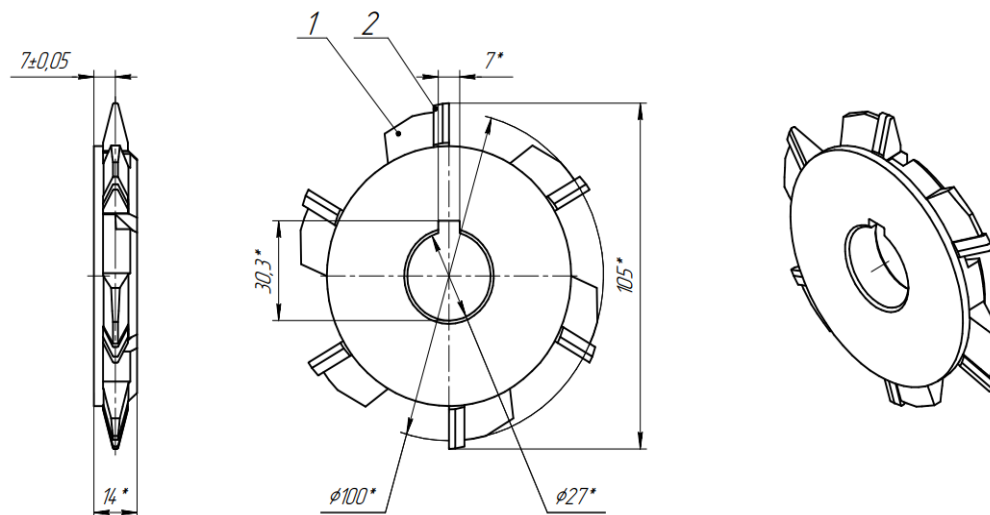

**Figure 1.** Special disc cutter for cutting trapezoidal profile threads.

Ensuring the required high accuracy indicators and quality of machining the threaded surfaces in the holes of complex housing parts is achieved by improving the special cutting tool [5].

### Research Methodology

The object of research is the “Valve box block” part of the K-4949.00.00.02 pump NB-125.00.00.000 (as given in Figure 2).

When cutting threads to the trapezoid profiles on the inner surfaces of the connecting parts, the valve box block was manufactured with the “Module be Tr140x8 HSS f100/27” disc cutter purchased abroad, made of R6M5 high-speed steel, in the cutting modes: tool rotation  $n = 160$  rpm, cutting depth for one pass  $t = 0.5$  mm, tool feed  $S = 150$  mm/min (tool stroke, movement along the diameter of the inner threaded surfaces), ten passes, thread cutting, two passes, and thread profile calibration [1].

The time for machining the threaded surfaces for one block of valve boxes was 8.038 hours (in each block there are 4 holes with Tr140x8-6g thread profiles), in addition, during the cutting process of the threaded surfaces of one part, the cutting edges of the cutter, intensive wear occurs within 1.2 mm, the thread tolerance  $TD_2 = 0.450$  mm.

There is no possibility of sharpening the cutting edge of the disc modular cutter. It is necessary to purchase a machine, in addition, it will prepare a specialist for performing these works. After each re-sharpening of the cutting edges of the disc cutter, it is necessary to adjust the program for mechanical processing in the machine control system. These moments lead to additional costs in the final deterioration of the quality of the machined threaded surfaces and an increase in the cost of the manufactured product [2].

### Analysis and Results

It's developed a special disc modular cutter Tr140x8-6g (see in Figure 1) with hard alloy cutting plates T15K6 for machining parts made of 35XMJI), BK8 (for machining parts made of CЧ20 a template for sharpening the cutting plates of a special tool made of Y7 tool steel for sharpening the cutting plates due to wear during the machining process given in Figure 2).

When the cutting surfaces of a special modular cutter wear within the established dimensions of 0.2 mm, sharpening is carried out using a template while maintaining the dimensions of the threaded surfaces, and at the same time, the cutting part of the cutter can be sharpened 15...20 times, having sufficient reserves.

There is no need to purchase special equipment for sharpening the cutting parts of a special disc modular cutter. It does not require a highly qualified specialist, the sharpening can be carried out by working personnel who have the skills and permission to work on sharpening machines due to the simplicity of the design. In addition, the cutting plates of a special disc modular cutter can be replaced if the result does not allow for re-threading with new cutting plates.

The cutting plates of a special modular cutter can be easily replaced when replacing the material of the machined parts with the necessary cutting plates (T15K6, BK8, etc.).

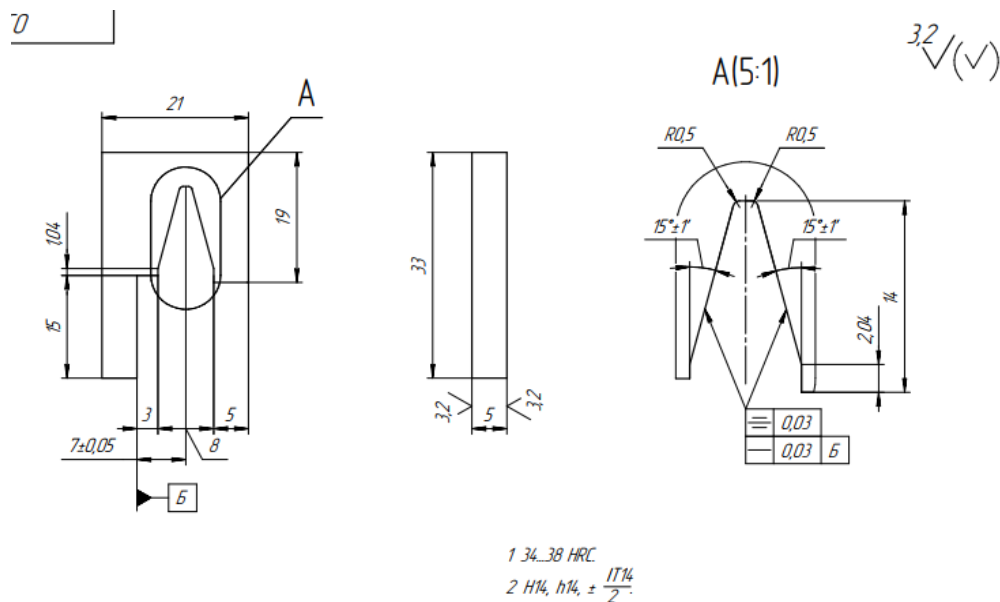

**Figure 2.** Template for sharpening the cutting plates of a special disc modular cutter.

The special disc modular cutter has the design of a housing made of structural steel, the cutting part of which is fixed to the housing by soldering. The T15K6 hard alloy plate, in cases of mechanical processing of a part made of structural steel, in the case of processing a part made of cast iron, the BK8, hard alloy plate, in our case, the part “Block of Valve Boxes” part ч. K-4949.00.00.02 prepared by K-4949.00.00.02, made of 35XMJI structural steel of the НБ-125.00.00.000 pump.

Studies of the working capacity of the developed special cutting tool were conducted under production conditions based on the “LLC GSS” multi-purpose machine model V center H1000.

The process of shaping thread surfaces with a trapezoidal profile was as follows: the mechanical processing of the “Valve box block” part K-4949.00.00.02 was carried out according to the technology on a multi-purpose V center H1000 machine, in four holes, thread shaping was carried out with a thread profile Tr140x8-6g, with a working process of 0.5 mm cutting depth for each working pass, two passes for calibrating thread surfaces.

The research was carried out in different modes of mechanical processing of cuts;





1. In cutting modes, the tool's rotation speed is  $n = 350$  rpm, the cutting depth per one cutting pass is  $t = 0.5$  mm, and the tool feed rate is  $S = 300$  mm/min. Ten working passes are for cutting threads, two passes are for calibrating the thread profile.

A strong vibration of the cutter was observed during operation, resulting in intensive wear of the cutting plate at a depth of 0.2 mm after machining one part, and the roughness of the machined threaded surfaces was  $R_z = 63$   $\mu\text{m}$ .

2. In cutting modes, the tool's rotation speed is  $n = 200$  rpm, the cutting depth per single cutting pass is  $t = 0.5$  mm, and the tool feed rate is  $S = 300$  mm/min. Ten working passes are for cutting threads, two passes are for calibrating the thread profile.

The milling cutter vibration during operation was observed due to the wear of the cutting surfaces of the cutting plate 0.2 mm after machining three parts, and the roughness of the machined threaded surfaces  $R_z = 40$   $\mu\text{m}$ .

3. In cutting modes, the tool rotation speed is  $n = 160$  rpm, the cutting depth per one cutting pass is  $t = 0.5$  mm, and the tool feed rate is  $S = 300$  mm/min. Ten working passes were used for cutting threads, and two passes were used for calibrating the thread profile.

The smooth operation of the cutter, the wear of the cutting surfaces of the cutter plates 0.2 mm after machining five parts, and the roughness of the machined threaded surfaces  $R_z = 20$   $\mu\text{m}$  were observed.

As a result of the research, it was established that the shaping of the thread surfaces by the trapezoidal profile of a special disc-modular cutter has an optimal mechanical processing regime with a tool rotation speed of  $n = 160$  rpm. The cutting depth of  $t = 0.5$  mm per one cutter stroke, a feed rate of  $S = 300$  mm/min per cutter stroke, ten working passes for cutting threads, and two passes for calibrating the thread profile.

The research was conducted on ten parts requiring mechanical processing, each having two threaded surfaces, the wear of the working plate was 0.2 mm after shaping the thread on the parts of ten valve box blocks, after turning the cutting plates of the cutter, the work on shaping the threaded surfaces of the valve box block parts continued.

The time for machining the threaded surfaces for one "Valve Box Block" unit of K-4949.00.00.02 was 4.019 hours.

## Conclusion

1. With the developed special disc cutter, it is possible to form threads with a trapezoidal profile in accordance with the requirements of GOST9484-2015.

2. This special disc model cutter can be manufactured at machine-building enterprises that have tool workshops due to its simple design.

3. When manufacturing a special modular cutter, there is no need to purchase special equipment; highly qualified workers have the opportunity to sharpen the cutting edges of the cutter; workers with skills in working with universal machines.

4. As a result of the development of a special modular disc cutter, the purchase of expensive special disc modular cutters in the republic for foreign currency was excluded. Savings in foreign currency funds amounted to several tens of times, the cost of one-disc modular cutter purchased abroad was 185 dollars, for shaping the threaded



surfaces of one part with low productivity. There is no equipment for turning the cutting part of the cutter.

#### References:

- [1] Kozhevnikov D.V., Kirsanov S.V. "Metal-cutting tools," Publ. *Tomsk Polytechnic University* 2009.
- [2] Skvorsov V.F. "Fundamentals Engineering Technology," Publ. *Tomsk Polytechnic University* 2012.
- [3] Inozemtsev G.G. "Designing metal-cutting tools," M. *Mechanical Engineering*. Moscow 1984.
- [4] Baranchikov V.I. "Instrumental Designer's Handbook," Moscow *Mechanical Engineering* 1994.
- [5] Usmanov K.B. "Designing cutting tools," Ministry of Higher and Secondary Specialized Education of the Republic of Uzbekistan. Academy. Tashkent 2006.
- [6] Mardonov B.T., Alikulov D.E., Irzaev A., Shakulov B.K. "Increasing the efficiency of cutting cylindrical gears," *Mining Bulletin of Uzbekistan*, № 4 (35), 2008, pp. 92-93.
- [7] Sakharov G.N., Arbuzov O.B., Borovoy Yu.L. and et al. "Metal-cutting tools," Textbook for universities in the specialty "Mechanical Engineering Technology," and "Metal-cutting tools" M. *Mechanical Engineering*, 1989.
- [8] Gryazev M.V., Fedorov Yu.N., Artomonov V.D. "Analysis of gear cutting processes of cylindrical gears," monograph. Tula: *Publishing house of Tula State University*, 2009.

UDC: 62, 621, 669, 669.1

## PROSPECTS FOR MANUFACTURING MODERN STRUCTURAL MATERIALS BASED ON IRON POWDER

**Shakirov Shukhrat Musaevich**

*Associate Professor (PhD), Department of  
Materials Science, Tashkent State Technical  
University named after Islom Karimov  
[goldstar\\_1471@mail.ru](mailto:goldstar_1471@mail.ru)*

**Аннотация.** Ushbu maqolada yuqori fizik – mexanik va ekspluatatsion xossalarga ega bo‘lgan temir kukuni asosli konstruksion materiallarni olishda qo‘llaniladigan: zamonaviy texnologiyalar; kukun xom ashyolari, sohada erishilgan amaliy va ilmiy natijalar hamda sohadagi mavjud muammolar tahlil etilgan.

**Калит so‘zlar:** *Innovatsiya, tahlil, texnologiya, tadqiqot, impuls, struktura, presslash, zichlik, harorat, matritsa.*

**Аннотация.** В данной статье проанализированы современные технологии, применяемые для получения конструкционных материалов на основе железного порошка с высокими физико-механическими и эксплуатационными свойствами; порошковое сырье, практические и научные результаты, достигнутые в этой области, а также существующие в ней проблемы.

**Ключевые слова:** *Инновация, анализ, технология, исследование, импульс, структура, прессование, плотность, температура, матрица.*

**Abstract.** This article analyzes modern technologies used in obtaining structural materials based on iron powder with high physical-mechanical and operational properties. It examines raw powder materials, practical and scientific results achieved in the field, and existing challenges in this area.

**Keywords:** *Innovation, analysis, technology, research, impulse, structure, pressing, density, temperature, matrix.*

## Introduction

The main modern trend in mechanical engineering continues to be the creation of machines and mechanisms with high operational properties and marketability based on obtaining structural materials with the necessary physical and mechanical properties. The automotive and tractor manufacturing industries remain the primary consumers of iron powder-based parts in mechanical engineering [7, 8]. In most developed countries, an average of 55-70% of iron powder-based parts are used in the automotive industry. At the same time, the consumption of iron powder-based parts is steadily increasing in the fields of aerodynamic technology, general mechanical engineering, and household appliances. In 1994, the global market sales volume of powder-based parts amounted to 3.8 billion dollars, and by 1998, it had reached 5.5 billion dollars [8].

## Literature Review

Unlike materials obtained through traditional technologies (casting, rolling, and mechanical cutting), powdered structural materials possess a certain degree of internal residual porosity [1-6]. The amount and shape of residual porosity in the structure strongly and negatively affect the physical and mechanical properties of the material [2]. Therefore, in CIS countries, powdered structural materials are classified based on the amount of internal residual porosity in their structure, taking into account operating conditions and load levels [5].

At the end of the 20<sup>th</sup> century, the rapid development of machinery and automotive industries in a number of countries around the world, including our Republic, necessitated the invention and implementation of new promising methods for obtaining structural materials in the field of powder metallurgy [19, 20]. As mentioned above, the main reason for the low mechanical properties of powder-based materials is the presence of inherent internal residual porosity. Its quantity primarily negatively affects the material's important properties - strength and impact toughness [1-3].

According to K.K. Mertens, I.A. Kasparov, V.N. Kokorin, P.A. Kuznetsov, and several other scientists, the essence of the problem lies in organizing the powder deformation process in such a way that ensures the plastic deformation activity involved in powder compaction is sufficient for the formation of a high-quality, non-porous structure, while maintaining the accuracy of the final dimensions of the press briquette as determined by the mold.

In most cases, powder compaction is carried out in rigid press molds made of tool steels. Several researchers have noted that pressing powders in a movable matrix significantly enhances the powder compaction process. The theory and technology of this method are comprehensively covered in the works of A.G. Ovchinnikov, A.M. Dmitriev, and a number of other scientists [9, 10].

### Analysis and Results

According to operational conditions, powdered structural materials are divided into general and special structural materials. The classification of powdered structural materials based on their load capacity and their physical and mechanical properties are presented in Table 1. As shown in Table 1, with a decrease in the amount of residual porosity in powdered structural materials, the tensile strength limit  $\sigma_B$  and the relative elongation  $\delta$  of the material increase significantly.

**Table 1.** Classification of powder structural materials according to the level of load [5].

Load level	Group of density	Internal residual porosity (%)	Percentage relative to material obtained through traditional methods		Density $\rho, \text{kg}/\text{m}^3$
			$\sigma_B$	$\delta$ and KCU	
Low-load	1	25...16	30...45	25...35	6000...6600
Light-load	2	15...10	45...65	35...60	6700...7000
Medium-load	3	9...2	65...95	60...90	7200...7700
Heavy-load	3	< 2	95...100	90...100	> 7700

The overall proportion of parts produced using powder metallurgy technologies and their application across various industries in some developed countries is presented graphically in Figure 1 [6, 8]. As evident from the graph, China and the USA are taking leading positions in terms of the application of parts manufactured through powder metallurgy methods across different sectors.

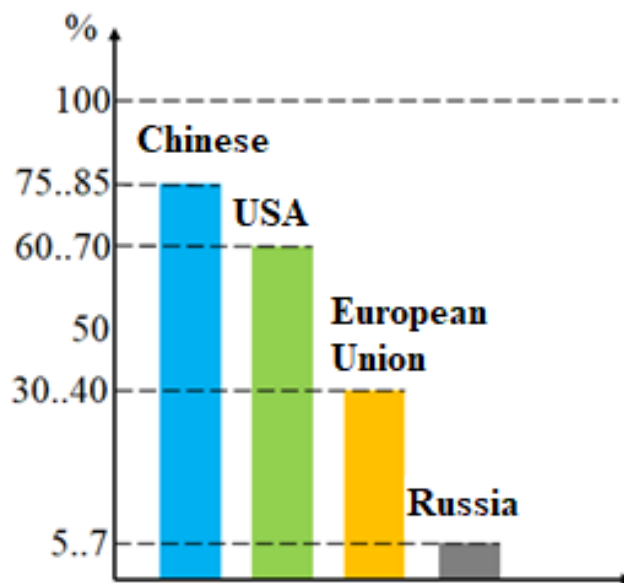

**Figure 1.** The proportion of powder-based parts used in various industries in some developed countries [8].

Information on the physical and mechanical properties of steel powder-based materials used in CIS countries, presented by the leading scientist in powder metallurgy, Academician O.V. Roman (Belarus), is provided in Table 2. The names, grades, manufacturing countries, chemical compositions, and main properties of powder-based structural materials used in foreign countries are presented in Table 3 [9].



As evident from Table 2 and Table 3, the classification system for powder-based structural materials in CIS countries differs slightly from that of foreign countries. For instance, in CIS countries, powder-based structural materials are categorized into four density groups: the first group with 6.0-6.6 g/cm<sup>3</sup>, the second with 6.7-7.1 g/cm<sup>3</sup>, the third with 7.2-7.7 g/cm<sup>3</sup>, and the fourth with > 7.7 g/cm<sup>3</sup>. This classification, in turn, allows for the grouping of powder-based structural materials into categories for light, standard, medium, and heavy-duty applications in the order described above.

**Table 2.** Physical and mechanical properties of steel powder materials (in untreated condition) [7].

Steel mark	$\sigma_B$ , GPa at least	$\delta$ , %, at least	$\Psi$ , %, at least	KS, kJ/m <sup>2</sup> , at least	E, GPa, at least	HB
Alloy10-1	100	6	10	200	80	50...70
Alloy 10-2	120	8	15	350	120	70...80
Alloy 10-3	150	12	28	500	150	80...90
Alloy 10-4	250	18	35	700	200	90...130
Alloy 30-1	120	6	10	200	80	50...70
Alloy 30-2	160	8	15	350	120	70...80
Alloy 30-3	200	12	25	500	150	80...90
Alloy 30-4	250	18	35	700	200	90...130
Alloy 70-1	120	5	10	150	84	50...70
Alloy 70-2	200	8	15	300	125	70...90
Alloy 70-3	280	10	20	400	160	90...110
Alloy 70-4	360	15	30	600	210	110...150
Alloy 90-1	120	2	8	100	85	60...80
Alloy 90-2	200	4	12	220	125	80...100
Alloy 90-3	300	6	20	300	160	100...120
Alloy 90-4	450	10	25	450	210	120...180

In foreign countries, the marking of powdered structural materials is determined by manufacturing companies or organizations specific to each country. When marking powder-based materials, the primary focus is on ensuring the ability to obtain powder materials with high physical and mechanical properties. These materials are presented within their threshold densities. For example, the density of powder structural materials proposed in Japan and Sweden falls within the range of 6.6 to 7.2 g/cm<sup>3</sup>.

In CIS countries, the use of powdered structural materials with a permissible residual porosity of 15-25% and correspondingly low mechanical strength is allowed mainly under operating conditions with small and simple loads. When designing parts from these materials, strength calculations are not performed, and their geometric dimensions are determined based on structural or technological considerations [2].

The density and strength of powder-based structural components used in medium and heavy-duty operational conditions must be equivalent to the density and strength of structural materials of the same grade produced through conventional technological methods. They are calculated for strength and rigidity, similar to parts obtained by traditional methods, and undergo heat treatment when necessary. A graphical comparison of the mechanical properties of powdered structural materials with those of structural materials obtained by traditional technological methods is presented in Figure 2 [8].

As evident from the graph, powdered structural materials with a residual porosity of less than 15% can fully compete in strength with cast iron and steel produced through various traditional technological methods. Moreover, after heat treatment, these materials with a porosity of 1% or less achieve strength equal to that of materials of the same grade obtained through traditional methods.

**Table 3.** Chemical composition and properties of structural steel grades manufactured in foreign countries [9].

Steel mark	Chemical composition, percentage by mass							$\rho$ , g/cm <sup>3</sup>	MPa		$\delta$ , %
	C	Ni	Cu	Si	Mn	Cr	Mo		$\sigma_B$	$\sigma_{0,2}$	
Sumiron 4100S, 6 / 1000 Japan	0,4	-	-	0,05	0,6- 0,9	0,8- 1,1	0,15- 0,3	7,1	-/1050	-	-
ASC.00.29, Sweden	0,6	-	-	-	0,6- 0,9	0,8- 1,1	0,15- 0,3	7,1	730/ 1100	-	-
	0,8	-	-	-	0,6- 0,9	0,8- 1,1	0,15- 0,3	7,1	1100/ 1250	-	-
	-	-	2,5	-	-	-	-	7,2	300	220	6
	0,4	-	0,5	-	-	-	-	-	300	270	3
	0,6	-	-	-	-	-	-	7,2	500	360	4,5
ABC100.3, Sweden	-	-	-	-	-	-	-	-	600	440	4,2
	0,2	-	-	-	-	-	-	7,1	280	160	11
	0,6	-	-	-	-	-	-	7,1	340	210	6
	0,2	-	2	-	-	-	-	7,1	350	240	6
	0,6	-	2	-	-	-	-	7,1	540	360	4
	0,2	-	-	-	-	-	0,45	7,1	420	300	8
	0,6	-	-	-	-	-	0,45	7,1	500	360	5
	-	3	-	-	-	-	-	7,1	260	150	17
SC100.24 Sweden	0,2	-	2	-	-	-	-	7,0	320	280	6,0
	0,6	-	2	-	-	-	-	7,0	500	400	3,0
	0,2	2,5	2,5	-	-	-	-	6,9	400	250	4,0
	0,6	2,5	2,5	-	-	-	-	6,9	530	420	2,5
NC100.24 Sweden	0,2	-	2	-	-	-	-	7,0	350	280	6
	0,6	-	2	-	-	-	-	7,0	500	360	3,5
	0,2	2,5	2,5	-	-	-	-	7,1	420	300	4,5
	0,6	2,5	2,5	-	-	-	-	7,1	550	470	2,5
Distloy SA Sweden	0,2	1,75	1,5	-	-	-	0,5	7,0	450/800	300/ 750	4/2
	0,6	1,75	1,5	-	-	-	0,5	7,0	580/ 1050	400/ 1000	2/1

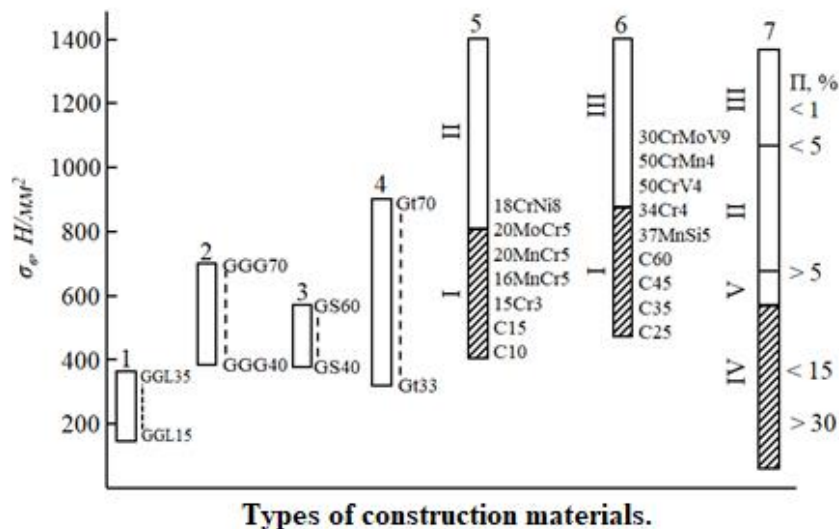

**Figure 2.** Comparison of the mechanical properties of powdered structural materials with those of structural materials obtained through traditional technological methods [8]: 1 - gray cast iron; 2 - ductile cast iron; 3 - cast steel; 4 - structural steel; 5 - case-hardening steel; 6 - heat-treatable steel; 7 - powder materials; I - normalizing and tempering; II - carburizing and quenching; III - heat treatment; IV - sintered; V - dispersion strengthened; P - residual porosity, %.

## Conclusion

Data on the types, properties, and applications of iron powder-based structural materials were analyzed. As a result, it was determined that structural materials based on iron powder, due to their physical and mechanical properties, are modern, in high demand on the world market, and have great potential for use in various industries.

Literature and research works on modern technologies used in the production of iron powder-based structural materials were analyzed. Consequently, the possibilities for manufacturing structural parts based on iron powder with high physical-mechanical and operational properties were identified.

A literature review was conducted on raw powder materials, grades, production methods, and properties used in the manufacturing of iron powder-based structural materials. As a result, the properties of iron powder raw materials necessary for the production of structural parts based on iron powder were determined.

## References:

- [1] "New Materials," Collected Authors. Edited by Yu. S. Karbasov. Moscow: *MISiS*. 2002, p. 736.
- [2] Libenson G.A., Lopatin B.Yu., Komarnitsky G.V. "Processes of powder metallurgy," In 2 volumes. Volume 2. Molding and sintering: Textbook for universities. Moscow: *MISiS*, 2002, p. 320.
- [3] Rogov V.A., Soloviev V.V., Kopylov V.V. "New materials in mechanical engineering," Textbook. manual. M.: *RUDN*, 2008, p. 324.
- [4] Soshina T.O., Trofimov V.N. "New materials and technologies: a teaching aid for universities," St. Petersburg: *Lan*, 2023, p. 196.
- [5] Narva V.K. "Technology of powder materials and products," course of lectures M.: *Publishing House MISiS*, 2012, p. 171.
- [6] William D. Callister, Jr. David G. Rethwisch "Materials Science and Engineering," New Jersey, Wiley and Sons, 2015.



- [7] Klimenkov S.S. "Design and production of blanks in mechanical engineering," textbook. Minsk: *Tekhnoperspektiva*, 2008, p. 407.
- [8] "Powder metallurgy in the world and in Belarus: 1990-2010," Status, problems, prospects - Belarusian Electronic Center "*Science*".
- [9] Roman O.V. "Powder steels," Mechanical Engineering: Encyclopedia. V.2. M.: *Mechanical Engineering*, 2000, p. 313.
- [10] Ilyushchenko A.F., Zvonarev E.V., Savich V.V. "State and Prospects of Development of Powder Metallurgy, Technologies of Application of Protective Coatings in the Republic of Belarus and Abroad," *Proceedings of the conference "Current Problems of Production and Application of Powder Metallurgy Products and Superhard Materials"*, Rostov-on-Donu, September 20, 2001, p. 14-30.

UDC: 62, 62, 621, 625.1

## DEVELOPMENT AND CURRENT STATE OF THE PASSENGER TRANSPORT SYSTEM IN RAIL TRANSPORT

**Ibragimova Gulshan Ruslanovna**

*Associate Professor (PhD), Department of  
Management of Railway Operation, Tashkent  
State Transport University*  
[ibragimova.gulshan@mail.ru](mailto:ibragimova.gulshan@mail.ru)

**Mirzabekova Umida Nishanbayevna**

*Special Science Teacher, Department of  
Organization and management of  
Transportation, Tashkent Transport Technical  
School*  
[9519559@mail.ru](mailto:9519559@mail.ru)

**Kulahmetov Oybek Pochchahonovich**

*Leading specialist of Temiryo 'lekspress' AJ*  
[bek\\_1109@mail.ru](mailto:bek_1109@mail.ru)

**Annotatsiya.** Hozirgi vaqtda jahonda yo'lovchilar temir yo'l transportini tashkil etishni o'rganish ko'rsatilayotgan xizmatlar sifatiga ta'sir qiluvchi bir qancha muhim jihatlarni aniqlashdan iborat. Temir yo'l transporti sohasida elektron tijoratni rivojlantirish va transport chiptalarini sotish tartibi va ushbu xizmat turlarining formati bo'yicha zamonaviy elektron tijorat texnologiyalaridan foydalanish. Elektron tijoratning rivojlanishi temir yo'l transportining o'sishiga yordam beradi, bu esa yo'lovchilarning qulayligini ta'minlaydi va ko'rsatilayotgan transport xizmati sifatini oshiradi.

**Kalit so'zlar:** ASU Express-3, veb-resurs, elektron chipta yo'lovchi tashuvchisi, sayohat hujjati, elektron registr, elektron chipta.

**Аннотация.** Исследование организации пассажирских железнодорожных перевозок в государстве в настоящее время заключается в выявлении нескольких важных аспектов, которые влияют на качество предоставляемых услуг. Развитие электронной коммерции в сфере





железнодорожного транспорта и использование современных технологий электронной коммерции для порядка продажи транспортных билетов и формата видов данной услуги. Развитие электронной коммерции способствует росту железнодорожного транспорта, что сделало возможным, обеспечивает комфорт пассажиров и повышает качество предоставляемых транспортных услуг.

**Ключевые слова:** АСУ Экспресс-3, веб-ресурс, электронный билет пассажира-перевозчика, проездной документ, электронный реестр, электронный билет.

**Abstract.** The study of the organization of passenger transport rail transport in the state currently consists of identifying a number of important aspects that affect the quality of service provided. The development of e-commerce in the field of rail transport and the use of modern e-commerce technologies for the order of the sale of transport tickets and format for the types of this service. The development of e-commerce promotes the growth of rail transport, has made it possible, provides passenger comfort, and improves the quality of the transportation service provided.

**Keywords:** ASU Express-3, web resource, the electronic ticket passenger carrier, travel document, electronic register, e-ticket.

## Introduction

The growing demand for passenger transportation has led to rapid advancements in rail transport systems. This expansion has also increased interest in rail as a key mode for freight movement. Passenger and freight rail services exist in a competitive yet complementary relationship with other transport modes, forming an integral part of multimodal logistics chains. Strategic planning, system design, performance evaluation, and management are critical structural components in optimizing rail networks.

## Literature Review

From a financial perspective, strategic planning must incorporate consumer demand analysis to ensure the economic viability of transport infrastructure. Enhancing profitability requires comprehensive planning and analysis, with demand forecasting being one of the most crucial aspects [1-3].

Public transport services depend on various factors, including seasonal variations, peak-hour demand, contractual agreements, and other operational considerations. These factors determine key aspects such as scheduling, transport capacity, railway infrastructure, passenger convenience, and safety standards. Consequently, if a passenger transport system possesses unique characteristics, transport operators must conduct continuous analysis and implement necessary adjustments to maintain efficiency.

Rail transport plays a crucial role in many national transportation systems, offering efficient and comfortable mobility for passengers. As urbanization and population mobility continue to grow in the modern world, rail-based passenger transport has

become an increasingly important research topic, attracting significant attention due to its capacity and advantages in terms of sustainability [4-7].

## Research Methodology

This study employs a mixed-methods approach, combining quantitative data analysis of passenger transportation statistics with qualitative evaluation of operational and infrastructural factors affecting rail transport efficiency. The methodology includes:

### 1. Data Collection

- Analyze time-series data (2019–2023) on passenger volumes, turnover, and growth rates from national rail transport reports.
- Review of technological implementations (e.g., ASU Express-3 e-ticketing system) and their impact on service quality.

### 2. Comparative Analysis

- Examination of pre-pandemic (2019), pandemic (2020–2021), and post-pandemic (2022–2023) passenger trends to assess recovery and growth.
- Benchmarking rail performance against other transport modes (road, air) in terms of capacity, reliability, and sustainability.

Our study relies on secondary data from government transport reports, academic literature, and industry publications, ensuring a comprehensive understanding of rail transport challenges and innovations.

## Analysis and Results

The country's transport system, the main task of the population and the state of traffic, the needs to meet, rail road passenger transport, while his leading element is. Iron road transport's own unique feature is its most important social function. Iron road transport passenger transport of other types, for example, car and air transport is an important alternative is. It has high conductivity, weather conditions, low correlation, and environmental efficiency, such as a number of advantages it has.

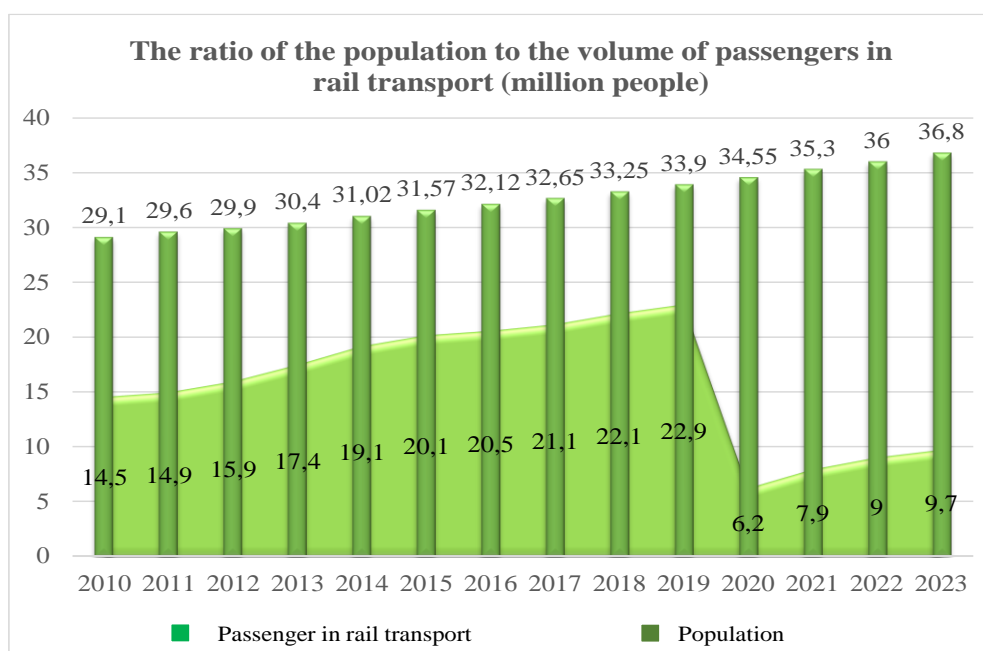

**Figure 1.** In railway transport, the size ratio and the number of passengers (million people).

However, this despite, rail road transport, passenger transport to the volume of various factors, in particular, the socio-economic situation changes, technological innovation, service provision level and other transport types with competitive effects have can.

Railway transport in December 2023 and January of the year by total passengers and shipped 9.7 million for the period compared to last year growth of 7.7 percent was recorded. 2022- January: Sent the number of passengers in the months of December 9,0 million people, compared to the same period of the year, a growth rate of 113,4 percent [3]. 2020 is the year from January to December, due to in a months of the pandemic sent passengers, the number of dramatically reduced (6,2 million people or 26,9%). 2023 is the year of January to December in the months of iron road transport network of passenger turnover volume 3926,0 million passenger miles to up has (2022 of the year same period compared to a growth rate 110,6% to up was), 2022 year 3549,4 (113,4 %), 2021 is the year of 3130,2 (174,4 %), 2020 year 1794,9 (40,9%) % ), 2019 year 4 385,2 million passenger-km (101,3 %) to up was.

Currently, in the organization of rail transport, attention is paid to the issues of e-commerce and the technical standards of transport serving passenger traffic in the economic development of the country. Optimization is underway by expanding the scope of work of the ASU Express-3 system since this issue indicates an improvement in the quality of passenger service [4]. This issue includes the development and introduction of the latest technical devices based on the monitoring of the main parameters of the development of passenger transport, more effective methods of Operation Management, increasing the level of passenger service, and the development of a mobile plan. Electronic registration for these trains is determined to be carried out from the starting station of the train line or from intermediate stations. In particular, electronic registration for a particular train is carried out in three stages [5].

The first stage involves the electronic registration of the passenger to a particular train along the entire route, and the train ends 1 hour before departure from the starting station. The second stage of electronic registration of railway administrations for interstate communication trains is done in the following order:

- the sale of electronic tickets, electronically registered in the formalization of travel on the interstate and domestic route under the interstate passenger transport tariff, will be stopped an hour before the train is shipped from the starting station;
- The sale of electronic tickets, electronically registered in the formalization of travel in domestic traffic by Administrative Region, is stopped at the specified time before the departure of the train from the passenger departure station.

The third stage involves the electronic registration of a passenger to a particular train along all lines, and on all the web resources of railway administrations using ASU Express-3, the train from the passenger's departure station ends no later than departure time. To board a train, a passenger provides an identity document to the car conductor, which is indicated on paper or electronic digital media (telephone, tablet, etc.) by an electronically registered electronic travel document and number in an electronic travel document [6].

Analysis of the volume of passenger transport in rail transport is of significant practical importance for the development of effective strategies for managing transport

infrastructure, improving the quality of passenger service, and ensuring the sustainable development of this industry [7].

First, it was found that there was a need to improve infrastructure and technical equipment. Many railroads require modernization, and older equipment often leads to delays and accidents. Therefore, infrastructure investments and technical Vehicle Upgrades Play an important role in improving transportation quality.

Secondly, the analysis showed the need to optimize the management and organization of passenger transportation. Frequent delays and cancellations of flights indicate the inefficiency of the current planning and control system. The introduction of modern information technology and the development of more efficient management algorithms can significantly reduce the number of incidents and increase the level of passenger satisfaction.

The third important aspect identified during the study is the need to improve the quality of passenger service. The work of railway transport personnel directly affects the level of comfort and safety of passengers. Measures to train employees, introduce service standards, and improve safety should be a priority for organizations engaged in passenger transportation in rail transport.

Finally, the analysis showed that an important aspect of the development of Rail Passenger Transport is environmental sustainability. With the growing awareness of climate change, the introduction of clean technology and the reduction of harmful emissions are becoming increasingly important tasks for the industry.

## Conclusion

Thus, the study makes it possible to conclude the need for an integrated approach to solving the problems of Rail Passenger Transport. Effective measures to modernize infrastructure, optimize management, improve the quality of Service, and improve environmental sustainability should be carried out together to achieve good results and meet the needs of passengers for reliable, convenient, and environmentally friendly transportation in rail transport.

## References:

- [1] Vykrebentsev I.S. "Forecast passenger flow and analysis of factors affecting passenger demand," *Moscow Economic Journal*. № 12, 2020, pp.789-796.
- [2] Ibragimova G.R., Goipov D.S. "Analysis of passenger transportation indicators of UTY JSC in the aspect of e-commerce development in transport," *Young Scientist*. №13 (408), 2022, pp. 345-350.
- [3] Ibragimova G.R., Goipov D.S. "Development of specialties taught in English to give birth to foreign students to the Universities of our country," Prospects for improving the integration of Science-Education-production in the training of competitive personnel. International scientific and technical conference collection of scientific articles and abstracts. Andijan: *AndMI*, 2024, p. 366.
- [4] Web study "National statistics committee of the republic of Uzbekistan," <https://stat.uz/ru/default/ezhekvtartal-ny-notes/39035-2023-2#tab>
- [5] Hamraeva S.N. "Specifics of the development of e-commerce and e-commerce in Uzbekistan," *Theory and practice of managing entrepreneurial structures in modern conditions*. 2023, pp. 107-113.



- [6] Petrochenko A.A., Ponomarev S.V. "Development of e-commerce in rail transport," Improving the efficiency of the transport system of the region: *Problems and prospects*. 2015, pp. 222-227.
- [7] Yepishkin I.A. "E-commerce in rail transport," *Textbook for Moscow universities*. Vol. 3, 2008.

UDC: 62, 621, 669, 669.1

## DISTRIBUTION OF RESIDUAL POROSITY BY HEIGHT IN VARIOUS SCHEMES OF PRESSING BUSHINGS FROM POWDERS

**Shakirov Shukhrat Musaevich**

*Associate Professor (PhD), Tashkent State Technical University named after Islom Karimov*  
[goldstar\\_1471@mail.ru](mailto:goldstar_1471@mail.ru)

**Karimov Shoir Akhrarovich**

*Professor (DSc), Tashkent State Technical University named after Islom Karimov*

**Annotatsiya.** Ushbu tadqiqot bir tomonlama va ikki tomonlama sovuq presslash usullariga e'tibor qaratib, chang metallurgiya mahsulotlarida qoldiq g'ovaklikning taqsimlanishiga presslash sxemalarining ta'sirini o'rganadi. Analitik modellashtirishdan foydalanib, g'ovaklikning vtulka shaklidagi kompakt balandligi bo'yicha taqsimlanishi baholanadi. Natijalar shuni ko'rsatadiki, bir tomonlama bosish g'ovaklikning bir xil bo'lmagan taqsimlanishiga olib keladi, presslash yuzasi yaqinida yuqori zichlik, ikki tomonlama presslash esa bir xil zichlikni ta'minlaydi, lekin o'rta qismda o'zgarishlarni ko'rsatadi. Olingan analitik ifodalar kerakli zichlik bir xilligiga erishish uchun presslash sxemalarini optimallashtirish imkonini beradi, minimal qoldiq g'ovaklikka ega yuqori samarali kukunli metallurgiya komponentlarini ishlab chiqarishni qo'llab-quvvatlaydi.

**Kalit so'zlar:** kukun metallurgiyasi, sovuq presslash, g'ovaklik, zichlik taqsimoti, presslash sxemalari.

**Аннотация.** В данной работе изучается влияние схем прессования на распределение остаточной пористости в изделиях порошковой металлургии с упором на одностороннее и двухстороннее холодное прессование. С помощью аналитического моделирования оценивается распределение пористости по высоте прессовки в форме втулки. Результаты показывают, что одностороннее прессование приводит к неравномерному распределению пористости с более высокой плотностью вблизи поверхности прессования, в то время как двухстороннее прессование обеспечивает более равномерную плотность, но демонстрирует вариации в средней части. Полученные аналитические выражения позволяют



оптимизировать схемы прессования для достижения желаемой однородности плотности, поддерживая производство высокопроизводительных компонентов порошковой металлургии с минимальной остаточной пористостью.

**Ключевые слова:** порошковая металлургия, холодное прессование, остаточная пористость, распределение плотности, схемы прессования.

**Abstract.** This study investigates the influence of pressing schemes on the distribution of residual porosity in powder metallurgy products, focusing on one-sided and two-sided cold pressing methods. Using analytical modeling, the distribution of porosity along the height of a bushing-shaped compact is evaluated. The results demonstrate that one-sided pressing leads to non-uniform porosity distribution, with higher density near the pressing surface, while two-sided pressing provides more uniform density but exhibits variations in the middle section. The derived analytical expressions allow for the optimization of pressing schemes to achieve the desired density uniformity, supporting the production of high-performance powder metallurgy components with minimal residual porosity.

**Keywords:** powder metallurgy, cold pressing, residual porosity, density distribution, pressing schemes.

## Introduction

Modern development of technology constantly puts forward the task of finding new materials with high-performance properties. In this regard, powder metallurgy methods are promising. Powder metallurgy is a branch that covers a set of methods for producing metal powders and metal-like compounds, as well as products from them or from their mixtures, while the main component is not brought to melting. The technology for obtaining powder structural materials and products includes operations of batch preparation, molding, high-temperature, and additional processing [1].

Powder molding is a technological operation that results in imparting to the powder body the specified shape, dimensions, density and mechanical strength necessary for subsequent operations of manufacturing products with a set of specified functional and mechanical properties. A large number of different molding methods are known for the production of powder products [2]. Depending on the type of the molded body in the initial state, these methods are distinguished: by the method of feeding the molded body to the molding elements of the working tool - into intermittent and continuous; depending on the molding temperature - into cold (at room temperature) and hot (at a temperature above the recrystallization temperature); by the method of applying pressure - into static methods (with constant or gradually increasing pressure) and methods without applying pressure.

Discontinuous methods with gradually increasing pressure include static pressing in a closed mold, hydro- and gas-static pressing, additional pressing, cold and hot stamping on presses. Discontinuous methods with instantly increasing pressure include impact, vibration, hydrodynamic, magnetic-pulse pressing, explosive pressing, and stamping on high-speed hammers. Slip casting and vibration powder laying are carried out without applying pressure. Continuous methods with constant tool pressure on the

formed body include rolling, with gradually changing (first increasing, then decreasing) pressure - die pressing, extrusion of blanks.

## Literature Review

The development of processes for obtaining high-quality products from metal powders is based largely on the development and use of new technologies for the consolidation of dispersed metals, aimed at significantly minimizing residual porosity and creating a regulated metal structure [3, 4].

The most common type of powder products for structural purposes used in mechanical engineering and automobile manufacturing are general-purpose parts based on iron. An analysis of the literature [5, 6] allows us to conclude that powder structural parts should have high density and strength, approaching dense and strong parts made from rolled and cast metal (residual porosity  $< 1\%$ ).

An analysis of known technologies for manufacturing powder parts shows that the use of hot hydrostatic isostatic pressing (HIP) allows one to obtain a structure with a residual porosity of (1...3) % and simultaneously increase the bending strength. However, existing HIP technologies are expensive, require the use of shells for powder encapsulation, and have limitations in terms of production types.

To obtain virtually pore-free powder products (porosity  $\theta_{\text{cor.}} \leq 1\%$ ), it is possible to use dynamic hot pressing (DHP), developed by Professor Yu. G. Dorofeev [7]. In this case, characteristic defects of blanks and parts obtained using the DHP technology are surface microcracks and pores; it has been established that high strength of products is not achieved since the particles of metal powder are covered with an oxide film, which complicates diffusion processes between them.

Problems associated with the use of traditional methods of compaction of powder materials have contributed to the development of new efficient technologies of pressing using shear [8]. To obtain high-density parts from a powder charge, it is necessary to carry out deformation using mechanical loading schemes in which shears are observed between particles. Under these conditions, the active surface of particles free of oxide films increases, and diffusion processes are intensified during sintering [9].

The work [10] shows the efficiency of increasing the density and its uniform distribution due to the reciprocating movement of the movable walls of the mold with a periodic change in the direction of movement.

Cold pressing in closed molds is the most common method used in the manufacture of products from ferrous, non-ferrous, and refractory metal powders [11]. Cold pressing in a closed mold is performed with a one- or double-sided application of load. One-sided pressing is used in the manufacture of simple-shaped products such as bushings and rings with a ratio of the product height to diameter of no more than one. The disadvantage of this method is the significant non-uniformity of the distribution of the compaction density in the pressing direction: its greatest value is observed near the matrix wall and under the movable punch, its lowest value is near the matrix wall near the movable punch [12].

Double-sided pressing, used in the manufacture of parts with a high height-to-diameter ratio, allows for a more uniform density distribution across the cross-section of the product. The most common method is one in which pressure is applied

simultaneously to the upper and lower punch [11]. When forming products such as bushings with a high height-to-wall-thickness ratio, the effect of the pressing pattern on the pressure value and the distribution of the average porosity across the cross-section by height is of interest. The work [13] is devoted to solving this issue using experimental methods. However, these methods do not provide an explicit form of the dependence of the density unevenness characteristics on the pressing pattern parameters and product dimensions.

In this paper, this issue is addressed using the concept developed in [14]. The two most common pressing schemes [11] are examined in detail: one-sided and two-sided pressing.

### Research Methodology

In the work [14], it was established that the pressing scheme of the bushing is completely determined by a pair of values  $z_a$  and  $z_b$  – coordinates of points on the inner and outer surfaces, in which the velocities of the rod and matrix, respectively, are equal to the velocities of the powder at these points. Each of the listed schemes is characterized by a pair of values  $z_a$  and  $z_b$  [14]: for one-sided pressing  $z_a = 0$ ,  $z_b = 0$ ; for two-sided pressing  $z_a = h/2$ ,  $z_b = h/2$ . In solving the above question, the following relationships obtained in [14] were used:

$$\sigma_z = p_{ax}(\theta_{av}) + \lambda p'_{ax}(\theta_{av})\theta^{(1)} \quad (1)$$

$$\theta = \theta_{av} + \lambda\theta^{(1)}, \quad (2)$$

$$p(h) = \frac{2}{b^2 - a^2} \int_a^b \sigma_z|_{z=h} r dz \quad (3)$$

$$p'_{ax}(\theta_{av}) \frac{\partial \theta^{(1)}}{\partial z} + \frac{\partial \tau_{rz}^{(1)}}{\partial r} + \frac{\tau_{rz}^{(1)}}{r} = 0 \quad (4)$$

$$\tau_{rz}^{(1)}|_{r=a} = p_{la}(\theta_{av}) \text{sign}(z - z_a); \quad (5)$$

$$\tau_{rz}^{(1)}|_{r=b} = -p_{la}(\theta_{av}) \text{sign}(z - z_b); \quad (6)$$

$$\int_0^h \int_a^b r \theta^{(1)} dr dz = 0. \quad (7)$$

Let us transform equation (4) to the form:

$$p'_{oc}(\theta_{cp}) \frac{\partial \theta^{(1)}}{\partial z} + \frac{1}{r} \frac{\partial}{\partial r} r \tau_{rz}^{(1)} = 0$$

and, multiplying both of its parts by  $r$ , we integrate within the limits from  $a$  to  $b$ . Then we get:

$$p'_{ax}(\theta_{av}) \frac{\partial \bar{\theta}^{(1)}}{\partial z} = -\frac{2}{b^2 - a^2} (b \tau_{rz}^{(1)}|_{r=b} - a \tau_{rz}^{(1)}|_{r=a}) \quad (8)$$

where  $\bar{\theta}^{(1)}(z) = \frac{2}{b^2 - a^2} \int_a^b \theta^{(1)} r dr$  - average porosity by height  $z$ .

Substituting into (8) the boundary conditions for  $\tau_{rz}^{(1)}$  from (5) and (6) we obtain:

$$\frac{d\bar{\theta}^{(v)}}{dz} = \begin{cases} \frac{2}{b-a} \cdot \frac{p_{la}(\theta_{av})}{p'_{ax}(\theta_{av})}, & \text{by } z_b \leq z \leq h \\ -\frac{2}{b+a} \cdot \frac{p_{la}(\theta_{av})}{p'_{ax}(\theta_{av})}, & \text{by } z_a < z < z_b \\ -\frac{2}{b-a} \cdot \frac{p_{la}(\theta_{av})}{p'_{ax}(\theta_{av})}, & \text{by } 0 \leq z < z_a \end{cases} \quad (9)$$

The function  $\bar{\theta}^{(v)}$  is continuous, so equation (9) can be integrated and the following relationship for the distribution of average porosity by height is obtained:

$$\bar{\theta}^{(v)}(z) = \begin{cases} 2 \frac{p_{la}(\theta_{av})}{p'_{ax}(\theta_{av})} \left( \frac{z}{b-a} - \frac{z_b + z_a}{b-a} - \frac{z_b - z_a}{b+a} \right) + \bar{\theta}^{(v)}(0), & \text{by } z_b \leq z \leq h \\ -2 \frac{p_{la}(\theta_{av})}{p'_{ax}(\theta_{av})} \left( \frac{z}{b+a} - \frac{z_a}{b+a} + \frac{z_a}{b-a} \right) + \bar{\theta}^{(v)}(0), & \text{by } z_a \leq z \leq z_b \\ -2 \frac{p_{la}(\theta_{av})}{p'_{ax}(\theta_{av})} \frac{z}{b-a} + \bar{\theta}^{(v)}(0), & \text{by } 0 \leq z \leq z_a \end{cases} \quad (10)$$

We determine the constant of integration  $\bar{\theta}^{(v)}(0)$  from condition (7), which can be rewritten as:

$$\int_0^h \bar{\theta}^{(v)}(z) dz = 0$$

Taking this condition into account, we integrate (10) from 0 to  $h$ . Then we get:

$$\bar{\theta}^{(v)}(0) = -2 \frac{p_{la}(\theta_{av})}{p'_{ax}(\theta_{av})} \cdot \frac{b \left[ (z_b - h)^2 - \frac{h^2}{2} \right] + a \left[ (z_a - h)^2 - \frac{h^2}{2} \right]}{h(b^2 - a^2)}. \quad (11)$$

Combining formulas (9) and (11), we obtain the final result (for  $p_{la}(\theta_{av})$  and  $p'_{ax}(\theta_{av})$  we write the function without arguments). Then we obtain:

$$\bar{\theta}(z) = \theta_{cp} + 2\lambda \frac{p_{\bar{\theta}}}{p'_{oc}} \cdot \left[ \frac{b(|z - z_b| - z_b) + a(|z - z_a| - z_a)}{b^2 - a^2} - \frac{b \left( (z_b - h)^2 - \frac{h^2}{2} \right) + a \left( (z_a - h)^2 - \frac{h^2}{2} \right)}{h(b^2 - a^2)} \right]. \quad (12)$$

## Analysis and Results

Formulas (11) and (12) are universal and take into account any scheme for producing a bushing by cold pressing under the same conditions of external friction on the outer and inner surfaces.

As follows from (10) and (11),  $\bar{\theta}(z)$  is a piecewise linear function. Substituting into these formulas the values of  $z_a$  and  $z_b$  corresponding to specific pressing schemes, we can obtain graphs of the porosity distribution by height:

one-sided pressing:

a)  $z_a = 0; \quad z_b = 0;$

b)  $\bar{\theta}^{(v)}(z) = \theta_{yp} + \lambda \frac{p_{\bar{\theta}}(\theta_{cp})}{p'_{oc}(\theta_{cp})} \cdot \frac{2z - h}{b - a};$

$$c) \bar{\theta}(z)_{\max} = \theta_{cp} - \lambda \frac{p_{\bar{o}}(\theta_{cp})}{p'_{oc}(\theta_{cp})} \cdot \frac{h}{b-a}; \quad \bar{\theta}(z)_{\min} = \theta_{cp} + \lambda \frac{p_{\bar{o}}(\theta_{cp})}{p'_{oc}(\theta_{cp})} \cdot \frac{h}{b-a};$$

$$d) P(h) = p_{oc}(\theta_{cp}) + \lambda p_{\bar{o}}(\theta_{cp}) \frac{h}{b-a}; \quad P(0) = p_{oc}(\theta_{cp}) - \lambda p_{\bar{o}}(\theta_{cp}) \frac{h}{b-a}.$$

double-sided pressing:

$$a) z_a = \frac{h}{2}, \quad z_b = \frac{h}{2};$$

$$b) \bar{\theta}^{(v)}(z) = \begin{cases} \lambda \frac{p_{\bar{o}}(\theta_{cp})}{p'_{oc}(\theta_{cp})} \left( \frac{2z}{b-a} - \frac{h}{2(b-a)} \right) + \theta_{cp}, & \text{arap } \frac{h}{2} \leq z \leq h \\ -\lambda \frac{p_{\bar{o}}(\theta_{cp})}{p'_{oc}(\theta_{cp})} \left( \frac{2z}{b-a} - \frac{h}{2(b-a)} \right) + \theta_{cp}, & \text{arap } 0 \leq z \leq \frac{h}{2}; \end{cases}$$

$$c) \bar{\theta}(z)_{\max} = \theta_{cp} - \lambda \frac{p_{\bar{o}}(\theta_{cp})}{p'_{oc}(\theta_{cp})} \cdot \frac{h}{2(b-a)}; \quad \bar{\theta}(z)_{\min} = \theta_{cp} + \lambda \frac{p_{\bar{o}}(\theta_{cp})}{p'_{oc}(\theta_{cp})} \cdot \frac{h}{2(b-a)};$$

$$d) P(h) = P(0) = p_{oc}(\theta_{cp}) + \lambda p_{\bar{o}}(\theta_{cp}) \frac{h}{2(b-a)}.$$

Using the resulting expressions, we will consider the distribution of the relative residual porosity by the height of the press briquette for both pressing schemes, for which we use the following initial data: dimensions of the sleeve: final height  $h = 10$  cm, outer radius  $b = 5$  cm, inner radius  $a = 3$  cm. final porosity  $\theta_{av} = 0.25$ , the coefficient of external friction was taken to be equal to  $\lambda = 0.2$ .

The calculations performed are presented in the form of a graph of the dependence of residual porosity on the pressing height (see Figure 1).

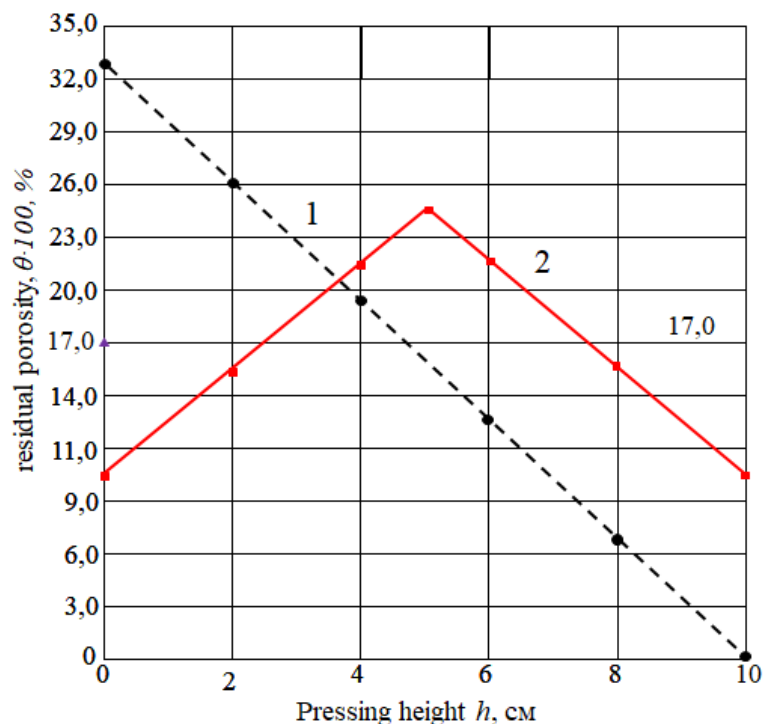

**Figure 1.** Residual porosity dependence on pressing height for different pressing schemes: 1 – one-sided pressing, 2 – two-sided pressing.



## Conclusions

With one-sided pressing, the distribution of residual porosity along the height of the pressing occurs unevenly relative to the upper part and the lower part of the pressing, and with two-sided pressing, the residual porosity along the height of the pressing occurs uniformly but varies greatly in the middle part of the pressing.

The characteristics of the pressing schemes obtained analytically can be used to solve an important technological question: the pressing schemes lead to the most uniform distribution of the porosity.

## References:

- [1] Kiparisov S.S., Libenson G.A. "Powder metallurgy," Textbook for technical schools. M.: *Metallurgy*, 1991. p. 432.
- [2] Radomyselsky I.D., Serdyuk G.G., Shcherban N.I. "Structural powder materials," K.: *Technology*, 1985, p. 152.
- [3] Kokorin V.N. "Analytical and experimental studies of the pressing process and structure formation during intensive compaction of moistened mechanical mixtures," *Strengthening technologies and coatings*, № 7, 2014, pp. 18-26.
- [4] Tsemenko V.N. "Processes of powder metallurgy," Theory and physical principles of compaction of powder materials: textbook. St. Petersburg: *Publishing House of the Polytechnic University*, 2005, p. 116.
- [5] Gorokhov V.M. "Warm pressing of structural products of complex shape from low-alloy steel powders," Minsk. *IPM. NASB*, 2007, pp. 109-115.
- [6] Findizer B., Friedrich E., Schatt V. "Powder Metallurgy," Sintered and Composite Materials, edited by V. Schatt. – M.: *Metallurgy*, 1983, p. 520.
- [7] Dorofeev Yu.G. "Dynamic hot pressing of porous powder blanks," M.: *Metallurgy*, 1977, p. 216.
- [8] Podryadov Yu.N. "The role of shear deformations in the consolidation of powder materials," *Physics and High Pressure Engineering*, Vol. 24, № 1, 2014, pp. 98-109.
- [9] Segal V.I. Reznikov et al. "Processes of plastic structure formation of metals," Moscow: *Science and Technology*, 1994, p. 232.
- [10] Bobryakov A.P., Shemyakin E.I. et al. "Method of compacting powder materials," – *Russian Federation Patent* № 1202706. Published. 1986.
- [11] Libenson G.A., Lopatin B.Yu., Komarnitsky G.V. "Processes of powder metallurgy," In 2 volumes. Volume 2. Molding and sintering: Textbook for universities. Moscow: *MISiS*, 2002, p. 320.
- [12] Narva V.K. "Technology of powder materials and products," course of lectures. M.: *Publishing House MISiS*, 2012, p. 171.
- [13] Radomyselsky I.D., Pechnovsky E.L. "The influence of the pressing tool on the density distribution in metallochemical materials such as bushings," *Powder Metallurgy*, № 4, 1970, pp. 13-19.
- [14] Shukhrat Shokirov et al. "Development of boundary conditions for the construction of a mathematical model of the process of pressing powder in a closed mold", *Electronic journal of Actual problems of modern science, education and training*, April, 2024, pp. 4-16.



UDC: 62, 621, 669, 669.1

## MICROSTRUCTURAL PROPERTIES OF COPPER-GRAPHITE COMPOSITES PREPARED BY COLD PRESSING METHOD

**Sultanov Sulaymon Safarboy Ugli**

*Ranch Technology University*

**Ismoilov Rakhmatjon Ilkhom Ugli**

*Teacher, Urgench State University named after Abu Rayhan Biruni*

**Mirzayev Otabek Taxir Ugli**

*Teacher, Urgench State University named after Abu Rayhan Biruni*

**Qadirov Islom Reyimbergan Ugli**

*Teacher, Urgench State University named after Abu Rayhan Biruni*

**Shakirov Shukhrat Musaevich**

*Associate Professor (PhD), Tashkent State Technical University named after Islom Karimov*  
[goldstar\\_1471@mail.ru](mailto:goldstar_1471@mail.ru)

**Allabergenov Bunyod Farkhodovich**

*Associate Professor (PhD), Urgench State University named after Abu Rayhan Biruni*  
[bunyod\\_kit@urdu.uz](mailto:bunyod_kit@urdu.uz)

**Annotatsiya.** Ushbu tadqiqot yuqori tezlikda harakatlanuvchi poezdlar uchun pantograf slayderlari kabi elektr kontaktlarida potentsial qo'llanilishi uchun turli xil grafit tarkibidagi (10, 20 va 30 og'irlik %) mis-grafit (CuGr) kompozitlarini ishlab chiqarish va tavsifini o'rganadi. Kompozitlar yuqori toza mis va grafit kukunlarini mexanik sharli tegirmonda aralashtirilib, so'ngra 2 tonna sovuqlayin presslash va oksidlanishni oldini olish uchun ko'mirga ko'milgan atmosferada 900 °C da termik pishirish yordamida tayyorlangan. Rentgen nurlarining diffraksiyasi (XRD) tahlili mis (Cu), grafit (C) va oz miqdorda mis oksidi (Cu<sub>2</sub>O) fazalarining mavjudligini tasdiqladi, grafitning eng yuqori cho'qqi intensivligi uning tarkibiga mutanosib ravishda ortib boradi. Brinell qattqlik sinovlari grafitning o'ziga xos yumshoqligi tufayli yuqori grafit konsentratsiyasi bilan qattqlikning sezilarli darajada pasayishi aniqlandi. Shu bilan birga, CuGr30 kompozitsiyasini uzoq muddatli issiqlik bilan ishlov berish (4-10 soat) chiziqli bo'lmagan qattqlik tendentsiyasini ko'rsatdi: grafit aglomeratsiyasi tufayli dastlabki pasayish (6 soatda 38,9 HB dan 27,9 HB gacha), so'ngra ko'tarilish (10 soatda 40,1 HB) mikrostrukturalararo bo'linish va mikrostrukturalarning yaxshilanishi bilan bog'liqligi aniqlandi. Mikrostrukturaviy tahlil bu ma'lumotlarni isbotini ko'rsatdi, bu grafit dispersiyasining yaxshilanganligini va uzoq muddatli termik pishirish bilan kuchli Cu-C o'zaro ta'sirini ko'rsatdi. Natijalar CuGr kompozitlarining mexanik xususiyatlarini optimallashtirishda grafit tarkibi va issiqlik bilan ishlov berish muddati muhimligini isbotladi.

**Kalit soʻzlar:** *Mis-grafit kompozitlari; chang metallurgiyasi; sinterlash; Brinell qattiqligi; mikro tuzilishi; elektr kontaktlari.*

**Аннотация.** В данной работе изучается изготовление и характеристика композитов медь-графит (CuGr) с различным содержанием графита (10, 20 и 30 мас.%) для потенциального применения в электрических контактах, таких как ползуны пантографа для высокоскоростных поездов. Композиты были приготовлены с использованием механического шарового измельчения порошков меди высокой чистоты и графита с последующим холодным прессованием при 2 тоннах и спеканием при 900 °С в восстановительной атмосфере на основе угля для предотвращения окисления. Анализ рентгеновской дифракции (XRD) подтвердил наличие фаз меди (Cu), графита (C) и незначительного оксида меди (Cu<sub>2</sub>O), причем интенсивность пика графита увеличивалась пропорционально его содержанию. Испытания твердости по Бринеллю показали значительное снижение твердости при более высоких концентрациях графита из-за присущей графиту мягкости. Однако длительная термообработка (4–10 часов) композита CuGr30 продемонстрировала нелинейную тенденцию к изменению твердости: первоначальное снижение (с 38,9 НВ до 27,9 НВ за 6 часов) из-за агломерации графита, за которым следует восстановление (40,1 НВ за 10 часов), приписываемое улучшенному межфазному связыванию и микроструктурной гомогенизации. Микроструктурный анализ подтвердил эти выводы, показав улучшенную дисперсию графита и более сильное взаимодействие Cu-C при длительном спекании. Результаты подчеркивают критическую роль содержания графита и продолжительности термообработки в оптимизации механических свойств композитов CuGr.

**Ключевые слова:** *композиты медь-графит; порошковая металлургия; спекание; твердость по Бринеллю; микроструктура; электрические контакты.*

**Abstract.** This study investigates the fabrication and characterization of copper-graphite (CuGr) composites with varying graphite content (10, 20, and 30 wt.%) for potential applications in electrical contacts, such as pantograph sliders for high-speed trains. The composites were prepared using mechanical ball milling of high-purity copper and graphite powders, followed by cold pressing at 2 tons and sintering at 900 °C in a coal-based reducing atmosphere to prevent oxidation. X-ray diffraction (XRD) analysis confirmed the presence of copper (Cu), graphite (C), and minor copper oxide (Cu<sub>2</sub>O) phases, with graphite peak intensity increasing proportionally with its content. Brinell hardness tests revealed a significant decrease in hardness with higher graphite concentrations due to graphite's inherent softness. However, extended heat treatment (4–10 hours) of the CuGr30 composite demonstrated a non-linear hardness trend: initial reduction (38.9 HB to 27.9 HB at 6 hours) due to graphite agglomeration, followed by recovery (40.1 HB at 10 hours) attributed to improved interfacial bonding and microstructural homogenization. Microstructural analysis supported these findings, showing enhanced graphite dispersion and stronger Cu-C interaction

with prolonged sintering. The results highlight the critical role of graphite content and heat treatment duration in optimizing the mechanical properties of CuGr composites.

**Keywords:** *Copper-graphite composites; powder metallurgy; sintering; Brinell hardness; microstructure; electrical contacts.*

## Introduction

The rapid advancement of high-speed electrical trains demands materials with superior electrical conductivity, thermal stability, and mechanical strength to ensure efficient power transmission and durability. Copper-graphite composites have emerged as a promising solution due to their unique combination of high electrical conductivity (from copper) and excellent lubricity, thermal resistance, and lightweight properties (from graphite) [1]. These composites are particularly advantageous for sliding electrical contacts, pantograph strips, and current collectors, where reduced wear and friction are critical for maintaining performance at high speeds [2].

The incorporation of graphite into copper matrices enhances tribological properties, minimizing energy losses and extending component lifespan [3]. Various fabrication techniques, such as powder metallurgy, spark plasma sintering (SPS), and electrodeposition, have been explored to optimize dispersion and interfacial bonding [4]. Additionally, the development of nanostructured copper-graphite composites has further improved mechanical strength while retaining high conductivity [5].

Despite these advantages, challenges such as graphite oxidation at elevated temperatures and inhomogeneous dispersion remain areas of active research [6]. Recent studies have investigated hybrid reinforcements, including carbon nanotubes (CNTs) and graphene, to enhance performance [7]. Furthermore, computational modeling and machine learning approaches are being employed to design optimized composite structures for high-speed rail applications [8-10].

This review explores the latest advancements in copper-graphite composites, focusing on their fabrication, properties, and performance in high-speed electrical trains. By addressing current limitations and future prospects, this study aims to contribute to the development of next-generation conductive materials for sustainable and efficient rail transport.

## Research Methodology

To prepare copper-graphite (CuGr) composites, 5 microsize powders with 99,9 % purity were used. The general parameters of the powders are presented in Table 1. For further understanding of the experimental process, a schematic illustration of the preparation of CuGr composites is shown in Figure 1. As given in Figure 1, the copper and graphite powders were mechanically mixed by the ball milling method. Then, it is molded into a stainless-steel mold with a diameter of 20 mm and a cold-pressing process by a mechanical oil press with a maximum load of 4 tons. Firstly, 3 samples with copper: graphite ratios of 90:10, 80:20, and 70:30 wt. % were prepared. The samples were named (marked) for further description purposes: a sample with 10% graphite was marked CuGr10; a sample with 20% graphite was marked CuGr20; and a sample with 30% graphite was marked CuGr30.

**Table 1.** Powder parameters obtained from the market.

No	Material name	Atomic number	View	Atomic mass (molar mass), m. a. b. (g/mol)	Density, g/sm <sup>3</sup>	Melting point, °C	Molar volume, cm <sup>3</sup> /mol
1	Mis(Cu)	29	Reddish soft metal	63,546	8,96	1 356	7,1
2	Grafit (Cr)	18	Light-black	12,011	2.09-2,23	3650	5,3

The mixture with 10 gr weight was dropped into mold and 2-ton double side punch pressing was done for prepare composite samples [11]. The pressing process and obtained samples with dimensions of 20 mm in diameter and 4-6 mm in thickness can be seen in Figure 2.

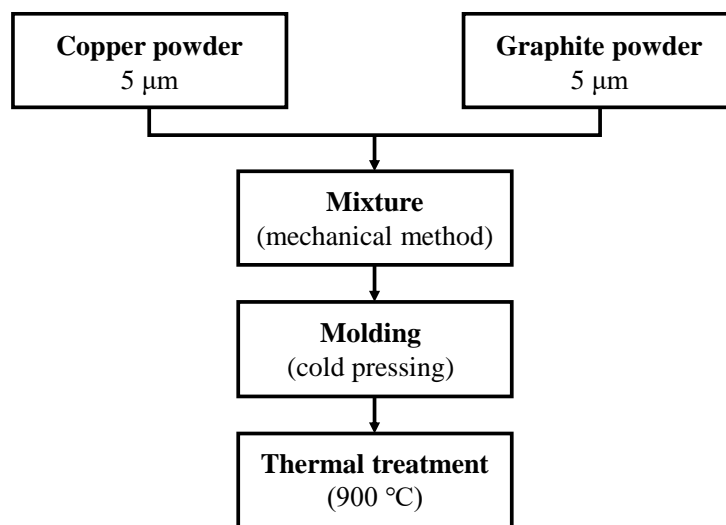
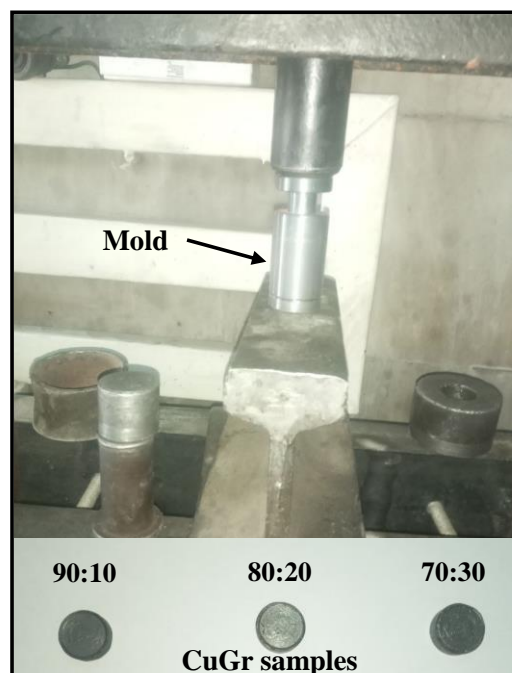
**Figure 1.** Schematic representation of the process of preparing a copper-graphite composite material.

**Figure 2.** Cold mechanical pressing process, stainless-steel mold and obtained CuGr samples.

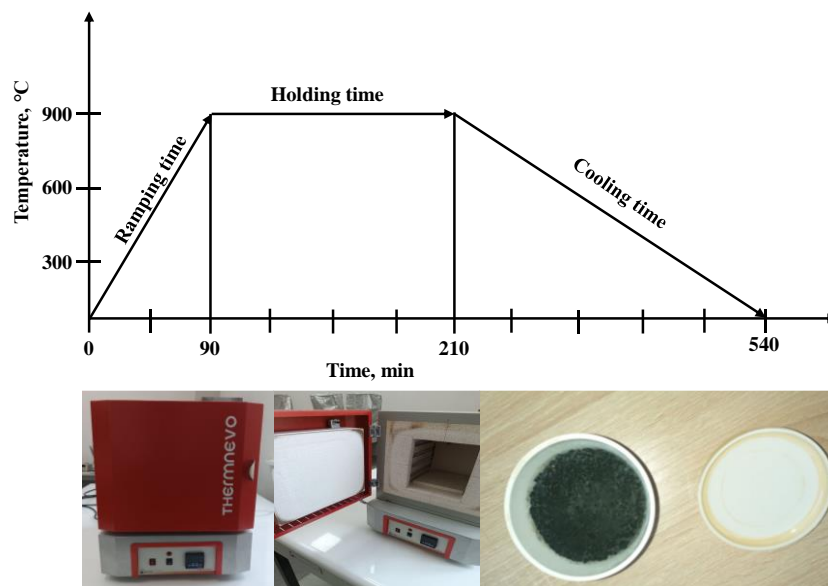

The samples obtained by cold pressing were placed in a vertical  $\text{Al}_2\text{O}_3$  heat-resistant ceramic vessel. To prevent graphite from oxidizing at high temperatures, ordinary local coal material was crushed by hand, the samples were buried with crushed coal, and the vessel lid was closed. The vessel with the samples was placed in a muffle furnace for baking. The electric muffle furnace program was adjusted to reach a temperature of  $900\text{ }^\circ\text{C}$  in 90 minutes and hold for 120 minutes.

The heat treatment conditions and furnace images are shown in Figure 3. Another 4 samples were prepared in a 70:30 ratio with different holding times, i.e., 4, 6, 8, and 10 hours. The state of the above 3 samples after heat treatment and polishing are shown in Figure 4. During the polishing process, 100, 300, 600, 800, 1200, and 2000 micro-size sandpaper was used in sequence. Then, I used a polishing powder with an  $\text{Al}_2\text{O}_3$  particle size of 3 micrometers.



**Figure 3.** Heat treatment graph, muffle furnace, and  $\text{Al}_2\text{O}_3$  ceramic vessel.

The polished samples CuGr10, CuGr20, and CuGr30 are now ready for microscopic analysis. Oxion inverse metallographic microscope Euromex Scope model was used to obtain microstructure images. All samples were prepared for analysis to study the microstructure, Brinell hardness (THBRV-187.5DX), X-ray diffraction pattern, and specific resistance properties.

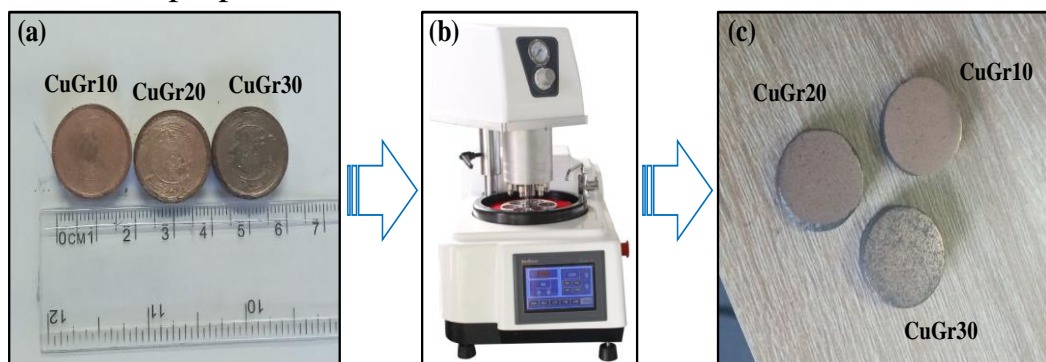
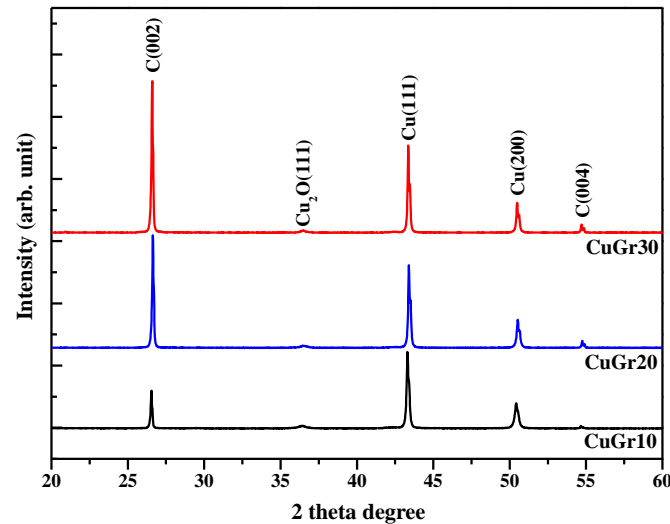

**Figure 4.** Condition of samples after heat treatment (a), (b) appearance of samples after polishing using the TIME-3000 polishing machine, and (c).

## Analysis and Results

The X-ray crystal structure analysis results of the copper-graphite composite samples were obtained and are presented in Figure 5. In the structure presented in Figure 5, it was observed that there were 5 peaks in the range of 20-60° taken at 2 $\theta$  angle for all composites: CuGr10, CuGr20 and CuGr30 samples. The peaks were consistent with the results of the X-ray Standard Element Database (RSEB) PDF#01-075-2078, PDF#03-065-9026, PDF#01-073-6237 and were mainly attributed to graphite, copper, and Cu<sub>2</sub>O with very low intensity.

During the analysis, it was determined that graphite has peaks corresponding to the Miller indexes (002), (004) at angles 26.5274°, 54.6625°, and they are marked as C(002), C(004) in Figure 5.



**Figure 5.** X-ray diffraction patterns of copper-graphite composite samples as the graphite content changes.

Copper was found to belong to the Miller indexes (111), (200) at angles of 43.3018°, 50.4098° and was designated as Cu(111), Cu(200). At the same time, the peak at an angle of 36.4903°, which belongs to copper oxide, with very low intensity, was designated as Cu<sub>2</sub>O(111).

The C(002) graphite peak intensity increased sequentially as the graphite content increased.

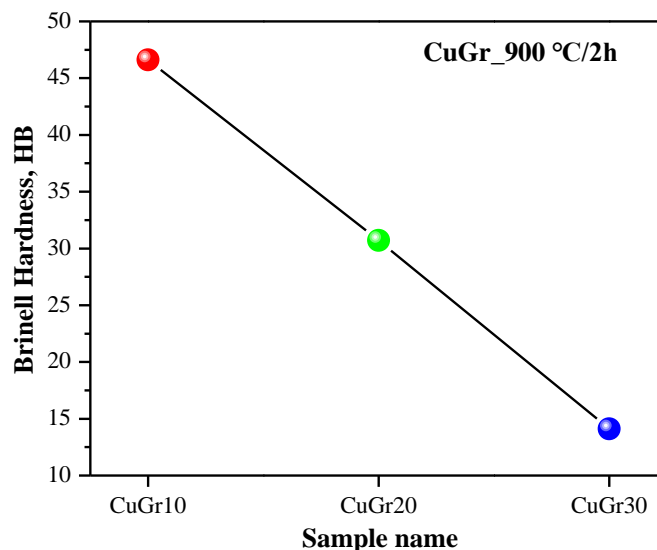

**Figure 6.** Graphite weight change of copper-graphite composite samples versus Brinell hardness.

Before measuring the Brinell hardness of copper-graphite samples, a 2.5 mm diameter ball was selected for the instrument, and the pressing force was adjusted to 120 N. These parameters were left unchanged for each sample. The hardness of the composite samples CuGr10, CuGr20, and CuGr30 was measured after annealing at 900 °C for 2 hours with an error of  $\pm 5$  °C, and the results are presented in Figure 6.

As can be seen in Figure 6, with the increase in the graphite content, the Brinell hardness continued to decrease sharply. This indicates that the amount of copper decreases and the graphite increases, meaning that copper is higher in hardness than graphite. However, I should also note that graphite is much better than copper in terms of corrosion resistance and is added to the composite to prevent copper from sticking to the electrical wire. We know that for CuGr composites to be used in high-speed trains, at least 40% graphite is close to the required level of the pantograph. If the amount of copper is high, it will rub against the current-carrying wires and even break them. Therefore, it is advisable to continue to study the copper-graphite CuGr30 in more depth and study it under different heat treatment time variations.

Table 1 shows the Brinell hardness values of the CuGr30 composite samples heat treated for 4, 6, 8, and 10 hours. In the table, when the heat treatment time increased from 4 hours to 6 hours, the hardness decreased from 38.9 HB to 27.9 HB. It can be caused by the increase in graphite agglomeration during treatment.

**Table 1.** Change in hardness of the CuGr30 composite sample according to heat treatment time.

<b>№</b>	<b>Heat treatment time (hour)</b>	<b>Graphite ratio, wt. %</b>	<b>Temperature, °C</b>	<b>Brinell hardness, HB</b>
1	4	30	900	38,9
2	6	30	900	27,9
3	8	30	900	37,9
4	10	30	900	40,1

When the heat treatment time was 8 hours, the composite hardness increased again and reached 37.9 HB. Thus confirms that with increasing heat treatment time, when it reached 10 hours, the hardness property increased to 40.1 HB. The hardness may have increased because copper and graphite adhered to each other and formed a homogeneous structure. In addition, we should not forget that the temperature is also of great importance. With increasing temperature, it is natural that processes such as diffusion bonding and densification occur.

Figure 7 shows the microstructure of the CuGr30 sample at 900 °C with a time variation and 20X magnification. This allows us to analyze more clearly the shape of the composite formed by the graphite particles with copper. In general, we can see that the graphite is less mixed between the copper in the samples that were kept for a shorter time, 2 and 4 hours. When researchers increased the heat treatment time to 6 and 8 hours, the graphite particles increased in the areas where the copper agglomerated and formed a perfect structure. This can be the basis for the higher mechanical properties.

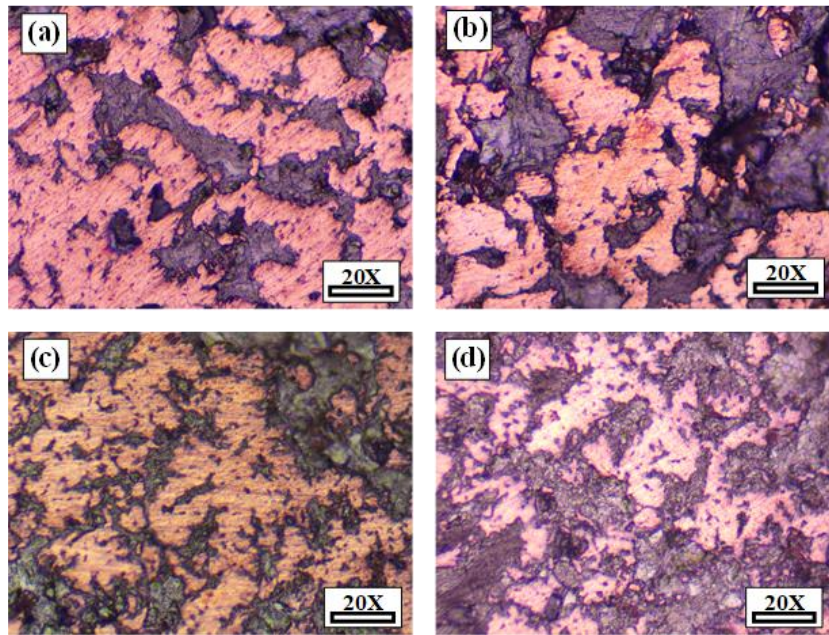

**Figure 7.** Microstructure of CuGr30 composite at 20X magnification obtained with varying heat treatment time: (a) 4 hours, (b) 6 hours, (c) 8 and (d) 10 hours, respectively.

## Conclusion

In this study, copper-graphite (CuGr) composites with varying graphite content (10%, 20%, and 30% by weight) were successfully prepared using mechanical ball milling, cold pressing, and heat treatment at 900 °C under a coal-based reducing atmosphere. The microstructure, phase composition, and mechanical properties of the composites were systematically investigated. X-ray diffraction (XRD) analysis confirmed the presence of copper (Cu), graphite (C), and minor copper oxide ( $\text{Cu}_2\text{O}$ ) phases in all samples. The intensity of the graphite peaks increased with higher graphite content, while the hardness of the composites, as measured by the Brinell hardness test, decreased significantly with increasing graphite content due to graphite's inherent softness compared to copper. Further investigation of the CuGr30 composite under different heat treatment durations (4–10 hours) revealed that hardness initially decreased (from 38.9 HB at 4 hours to 27.9 HB at 6 hours), likely due to graphite agglomeration, but then increased again (reaching 40.1 HB at 10 hours), suggesting improved interfacial bonding and homogenization at longer sintering times. Microstructural analysis supported this observation, showing better graphite dispersion and stronger copper-graphite interaction with extended heat treatment.

These findings highlight the importance of optimizing graphite content and heat treatment conditions to achieve a balance between mechanical properties and functional performance, particularly for applications such as pantograph sliders in high-speed trains, where reduced friction and wear resistance are critical. Future studies should explore higher graphite concentrations ( $\geq 40\%$ ) and alternative sintering techniques to further enhance the composite's performance for industrial applications.

## References:

- [1] Zhang Y., et al. "Enhanced electrical and tribological properties of copper-graphite composites for high-speed rail applications," *Materials & Design*, 185, 2020, p. 108245.
- [2] Chen H., et al. "Tribological behavior of copper-graphite composites under high-speed sliding conditions," *Wear*, 408, 2018, pp. 22-31.





- [3] Li X., et al. "Microstructure and properties of copper-graphite composites fabricated by spark plasma sintering," *Journal of Alloys and Compounds*, 786, 2019, pp. 792-801.
- [4] Wang L., et al. "Recent advances in powder metallurgy-based copper-graphite composites for electrical contacts," *Advanced Engineering Materials*, 23(4), 2021, p. 2000987.
- [5] Kumar R., et al. "Nanostructured copper-graphite composites with improved mechanical and electrical properties," *Composites Part B: Engineering*, 216, 2022, p. 108845.
- [6] Singh P., et al. "Oxidation resistance strategies for copper-graphite composites in high-temperature applications," *Corrosion Science*, 194, 2023, p. 109932.
- [7] Zhao M., et al. "Graphene-reinforced copper-graphite composites for ultra-low wear electrical contacts," *Carbon*, 192, 2023, pp. 198-210.
- [8] Guo S., et al. "Machine learning-assisted design of high-performance copper-graphite composites," *Acta Materialia*, 242, 2024, p. 118456.
- [9] Rajan T.P.D., et al. "Hybrid copper-graphite-CNT composites for next-generation pantograph systems," *Materials Today Communications*, 31, 2022, p. 103456.
- [10] Park J., et al. "Thermal management in copper-graphite composites for high-speed electrical trains," *International Journal of Heat and Mass Transfer*, 172, 2021, p. 121156.

UDC: 62, 621, 669, 669.1

## ANALYSIS OF IDENTIFICATION METHODS OF NON-METALLIC INCLUSIONS IN STEEL GRADE 110G13L

**Ashurov Khisrav Khurshid Ugli**

*PhD student, Navoi State University of  
Mining and Technologies*  
[kh\\_ashurov@mail.ru](mailto:kh_ashurov@mail.ru)

**Khamroev Nurbek Nurilloevich**

*PhD student, Navoi State University of  
Mining and Technologies*  
[nurbek.hamroyev92@gmail.com](mailto:nurbek.hamroyev92@gmail.com)

**Yakhshiev Sherali Namozovich**

*Docent, Navoi State University of Mining  
and Technologies*  
[sheraliyaxshiyev1978@mail.ru](mailto:sheraliyaxshiyev1978@mail.ru)

**Tangatarova Laylo Alijon Kizi**

*Master student, Navoi State University of  
Mining and Technologies*  
[laylotangatarova9@gmail.com](mailto:laylotangatarova9@gmail.com)

**Annotatsiya.** Maqolada 110G13L markali po‘latdagi metallmas qo‘shimchalarni aniqlash usullari ko‘rib chiqilgan. Oksidlar, sulfidlar va nitridlarni aniqlash imkonini beruvchi elektrolitik ekstraksiya usuliga alohida e‘tibor qaratilgan. Qo‘shimchalarni tahlil qilishning turli usullari, jumladan metallografiya, rentgen difraksiyasi va spektroskopik usullar ko‘rib chiqilgan. Yuqori marganesli po‘latda alyumosilikatlar va oksisulfidli qo‘shimchalar asosiy rol o‘ynashi aniqlangan. Po‘lat sifatini yaxshilash uchun kislorod, fosfor va boshqa aralashmalar miqdorini nazorat qilish muhimligi ko‘rsatilgan.



**Kalit so'zlar:** *Metallmas qo'shimchalar, yuqori marganesli po'lat, 110G13L, elektrolitik usul, oksidsizlantirish, alyumosilikatlar, oksidli qo'shimchalar, po'lat sifati.*

**Аннотация.** В статье рассматриваются методы идентификации неметаллических включений в стали марки 110Г13Л. Особое внимание уделено электролитическому методу экстракции, позволяющему выявить оксиды, сульфиды и нитриды. Рассмотрены различные методики анализа включений, включая металлографию, рентгеновскую дифракцию и спектроскопические методы. Установлено, что ключевую роль в высокомарганцевой стали играют алюмосиликаты и окисульфидные включения. Показана важность контроля содержания кислорода, фосфора и других примесей для улучшения качества стали.

**Ключевые слова:** *Неметаллические включения, высокомарганцевая сталь, 110Г13Л, электролитический метод, раскисление, алюмосиликаты, оксидные включения, качество стали.*

**Abstract.** The article discusses methods for identifying non-metallic inclusions in 110G13L steel. Particular attention is paid to the electrolytic extraction method, which allows the identification of oxides, sulfides, and nitrides. Various methods for analyzing inclusions are considered, including metallography, X-ray diffraction, and spectroscopic methods. It is established that aluminosilicates and oxysulfide inclusions play a key role in high-manganese steel. The importance of monitoring the content of oxygen, phosphorus and other impurities for improving the quality of steel is shown.

**Keywords:** *Non-metallic inclusions, high-manganese steel, 110G13L, electrolytic method, deoxidation, aluminosilicates, oxide inclusions, steel quality.*

## Introduction

Numerous studies have shown that non-metallic inclusions are a key factor in determining the melting properties of steel. Their nature and characteristics largely depend on the processes of final deoxidation and modification. During the formation of liquid steel, oxides, sulfides, and nitrides of those elements that have the highest free energy of formation under given conditions are predominantly formed [1-3]. Accordingly, the amount, type, and distribution of non-metallic inclusions are closely related to the residual content of elements prone to easy oxidation, which are introduced into the melt at the deoxidation stage. The detection of non-metallic inclusions in a steel alloy is a key step in assessing the quality of metallic materials. These inclusions have a significant effect on the mechanical properties, corrosion resistance, and technological processability of steel [4-6].

## Literature Review

Non-metallic inclusions (NMIs) are a critical factor influencing the mechanical properties, corrosion resistance, and processability of steel [7-9]. These inclusions originate from deoxidation, reoxidation, slag entrapment, and refractory erosion during steelmaking [10-12]. The composition, size, and distribution of NMIs depend on the

steel grade, deoxidation practice, and solidification conditions [7]. High-manganese steels, such as 110G13L (Hadfield steel), are particularly sensitive to inclusions due to their work-hardening properties, where inclusions can act as stress concentrators [5, 7].

## Research Methodology

To detect and study, several methods are used, including various approaches and tools: Metallographic method (optical microscopy), metallographic method using an electron microscope (SEM/EDS), extraction methods (electrolytic and chemical), X-ray diffraction (XRD), spectroscopy methods (for example, ICP-MS, AES), ultrasonic method (NDT - non-destructive testing), color flaw detection method. Non-metallic oxide inclusions were determined in samples of 110G13L steel smelted in an electric arc furnace at the Navoi Machine-Building Plant.

**Table 1.** Chemical composition of samples.

Technical information	Mass fraction of an element, %						
	C	Mn	Si	S	P	Cr	Ni
				no more			
GOST 977-88	0,90-1,50	11,5- 15,0	0,30-1,00	0,050	0,120	1,00	1,00
GOST 21357-87	0,90-1,20	11,5- 14,5	0,40 -0,90	0,030	0,08	0,30	0,30
ES 30745022-038:2022	0,90-1,10	11,5-14,5	0,20-0,60	0,05	0,10	1,0	0,5

## Analysis and Results

To extract non-metallic inclusions, an electrolytic method was used, which is based on the anodic dissolution of the metal base under the influence of electric current in an electrolytic solution. The electrolyte was a composition traditionally used to extract inclusions from low-alloy steels. This solution included a 3% solution of ferrous sulfate with the addition of 1% sodium chloride and 0.1% sodium citrate. To process one sample, 2 liters of this solution were required. Cylindrical samples with a diameter of 18-20 mm and a length of 30-40 mm were used for the experiment. To prevent contact of the copper wire with the surface of the sample, its upper part was insulated with a fragment of rubber tube. Then, the sample was placed in a collodion bag filled with an electrolytic solution, which was then fixed with a soft thread and immersed in an electrolytic bath. The current during electrolysis was 2 A per sample. The process lasted from 12 to 14 hours, during which time approximately 22-24 g of steel dissolved. After the electrolysis was complete, the bag with the sample was transferred to a porcelain cup and cut open, and the contents were washed into the cup. The sediment particles that had stuck to the surface of the sample were carefully removed with a glass rod with a rubber tip and also sent into the cup. The resulting sediment was slightly crushed with a pestle, then transferred to a half-liter glass, adding 250-350 ml of water. The mixture was left for 15-17 hours for the particles to settle completely. The transparent upper layer of liquid was drained with a siphon, and the sediment, together with the remaining liquid (about 140-160 ml), was filtered through a dense filter (blue tape) filled with paper pulp. Next, the sediment was washed 3–4 times with a 1% cold solution of sodium or ammonium citrate and then another 2–3 times with cold water.

When the process of carbide destruction is complete, the solution becomes transparent, and a grayish sediment forms at the bottom of the glass, which is oxide



non-metallic inclusions. After this, 200-250 ml of water is added to the glass, and the mixture is left for 12-16 hours to settle. The main part of the liquid is then carefully drained using a siphon, and the remaining volume (approximately 75-100 ml), together with non-metallic inclusions, is filtered through a dense filter. The sediment obtained on the filter is thoroughly washed with cold water to remove residual acid completely. Then, the filter with the sediment is calcined in a pre-weighed platinum crucible. The difference in weight before and after calcination allows us to determine the total amount of non-metallic oxide inclusions. The calcined sediment is analyzed for the content of free iron and aluminum oxides, as well as the amount and composition of silicates. To determine the amount of free iron oxide, the precipitate in the crucible is treated with 10 ml of hydrochloric acid (in a 1:1 ratio). The mixture is heated almost to the boiling point for 15–20 minutes. After this, the precipitate is filtered through a dense paper filter containing paper pulp and calcined. The difference in the mass of the sample before and after treatment with hydrochloric acid allows one to determine the content of free iron oxide. The amount of iron and manganese is determined in the resulting solution. To determine the content of silicic acid, the precipitate in the crucible remaining after treatment with hydrochloric acid is treated with a mixture of sulfuric and hydrofluoric acids. Then, the solution is heated until the sulfuric acid vapors completely evaporate. After this, the precipitate is calcined and weighed. The amount of silicic acid in the silicates is determined by the difference in the mass of the precipitate before and after treatment.

To determine the free aluminum oxide content, the crucible residue is treated with 10 ml of concentrated hydrochloric acid while heating. Silicate oxides dissolve, leaving free aluminum oxide in the residue. The solution is filtered into a 100 ml flask, and the residue is calcined and weighed. The aluminum oxide content is calculated by subtracting the empty crucible mass from the total mass. The difference in values determines the aluminum oxide in non-metallic inclusions.

Manganese and iron oxides in silicates are analyzed from the filtrate. For manganese oxide, 50 ml of the solution is mixed with 5 ml of sulfuric acid, heated until white sulfuric anhydride vapors appear, and manganese is measured volumetrically with persulfate. The remaining solution is used to determine iron content via a colorimetric method, forming a yellow color with sulfosalicylic acid.

## Conclusion

The conducted study of methods for identifying non-metallic inclusions in 110G13L steel showed that their composition, shape, and distribution have a significant impact on the performance properties of the material. The most effective method for isolating non-metallic inclusions was the electrolytic method, which allows reliable identification of oxides, sulfides, and nitrides. It was found that aluminosilicates, oxysulfides, and phosphide inclusions, which are formed depending on the deoxidation conditions and metal pouring temperature, play a significant role in high-manganese steel. To increase the purity of steel and improve its performance characteristics, it is recommended to improve the final deoxidation process, aimed at reducing the content of harmful impurities and controlling the shape of inclusions. The results obtained can



be used to optimize the production technology of high-manganese steel and improve the quality of castings.

#### References:

- [1] Davydov N.G., Sitnov V.V. “Properties, Production and Application of High-Manganese Steel,” *Mechanical Engineering*, Moscow, 1996, p. 232.
- [2] Yakhshiev Sh., Egamberdiev I., Mamadiyarov A., Ashurov Kh., Khamroev N. “Accuracy evaluation of the output of the spindle assembly of the NT-250I lathe machine,” *Research on Engineering Structures & Materials*, 9(1), 2023, pp. 163-179. DOI:10.17515/resm2022.523me0914
- [3] Khamroev N., Egamberdiev I., Ashurov Kh., Asatov S., Khamidov B. Exploring the influence of the casting process, structural components and heat treatment on the mechanical properties of high-chromium cast irons,” *A review. AIP Conf. Proc.* 3244, 2024, 060021. DOI: 10.1063/5.0241423
- [4] Beraha E., & Shpigler B. “Color Metallography,” *ASM International*, 1977.
- [5] Brooksbank D., & Andrews K.W. “Thermal Expansion of Inclusions and Their Effect on Steel,” *Journal of the Iron and Steel Institute*, 210(3), 1972, pp. 246–255.
- [6] Cullity B.D. “Elements of X-ray Diffraction,” *Addison-Wesley*, 1978.
- [7] Duckworth W.E., & Baird J.D. “The Identification of Non-Metallic Inclusions in Steel,” *Journal of the Iron and Steel Institute*, 207, 1969, pp. 854–871.
- [8] Goldstein J., et al. “Scanning Electron Microscopy and X-ray Microanalysis,” *Springer*, 2003.
- [9] Guthrie R., & Isaac M. “Continuous Casting of Steel: Fundamentals,” *McGill University*, 2015.
- [10] Kiessling R. “Non-Metallic Inclusions in Steel,” *The Institute of Materials*, 1989.
- [11] Turkdogan E.T. “Fundamentals of Steelmaking,” *The Institute of Materials*, 1996.
- [12] Zhang L., & Thomas B.G. “Inclusions in Continuous Casting of Steel,” *ISIJ International*, 43(3), 2003, pp. 271–291.



## ACTUAL PROBLEMS OF NATURAL SCIENCES

UDC: 66, 547

### STUDY OF THE THERMOGRAVIMETRIC PROPERTIES OF THE SCHIFF BASE BASED ON CHITOSAN APIS MELLIFERA WITH GLUTARALDEHYDE

**Ulashov Sherbek Mukhiddin Ugli**

*Doctorate, Tashkent State Technical University named after Islam Karimov*  
[sherbekjonulashov@gmail.com](mailto:sherbekjonulashov@gmail.com)

**Ikhtiyarova Gulnora Akmalovna**

*Professor, Tashkent State Technical University named after Islam Karimov*

**Akhmedova Sabina Mansur Kizi**

*Student, Tashkent State Pediatric University*

**Annotatsiya.** Ushbu maqolada chitosan va uning Schiff asoslarining termogravimetrik xossalari bo'yicha tadqiqotlar natijalari keltirilgan. Mualliflar HyperChem 8.0 dasturida molekulyar modellashtirishdan foydalangan holda Schiff bazasining (Xz-G) tuzilishini o'rganishdi. Kuzatilgan issiqlik hodisalari Schiff asoslarining barqarorligi va o'tishlari haqida tushuncha beradi, shuningdek, xitozan va glutaraldegiddan olingan Schiff asoslarining tuzilishi aminokislotalarning karbonil guruhlari bilan bog'lanishi bilan tavsiflanadi.

**Kalit so'zlar:** Chitosan, Schiff asoslari, glutaraldegid, issiqlik xossalari, aminokislotalar, Apis Mellifera, sintez, harorat, massa yo'qotish, molekulyar modellashtirish.

**Аннотация.** В данной работе представлены результаты исследований термогравиметрических свойств хитозана и оснований Шиффа на его основе. Авторами была изучена структура основания Шиффа (Xz-G) с помощью молекулярного моделирования в программе Hyper Chem 8.0. Наблюдаемые термические явления дают представление о стабильности и переходах оснований Шиффа, а также о том, что структура оснований Шиффа, полученных из хитозана и глутарового альдегида, характеризуются связями аминокислотных групп с карбонильными группами.

**Ключевые слова:** Хитозан, основания Шиффа, глутаровый альдегид, термические свойства, аминокислотная группа, Apis Mellifera, синтез, температура, потеря массы, молекулярное моделирование.

**Abstract.** This paper presents the results of studies on the thermogravimetric properties of chitosan and its Schiff bases. The authors investigated the structure of the Schiff base (Xz-G) using molecular modeling in the HyperChem 8.0 program. The observed thermal phenomena provide insight into the stability and transitions of Schiff bases, as well as demonstrate that the structure of Schiff bases



obtained from chitosan and glutaraldehyde is characterized by the bonding of amino groups with carbonyl groups.

**Keywords:** Chitosan, Schiff bases, glutaraldehyde, thermal properties, amino group, *Apis Mellifera*, synthesis, temperature, mass loss, molecular modeling.

## Introduction

Basic Schiff metal complexes have attracted significant attention from the scientific community due to their unique properties and versatile applications in various fields, including industry, medicine, and biology. These complexes exhibit diverse biological activities, including antiviral, cytostatic, antibacterial, antitumor, and antifungal properties. In addition, they possess exceptional catalytic activity for a wide range of compounds. According to studies [1], the crosslinking reaction of chitosan with glutaraldehyde (GA) is used to produce fibers, films, microspheres, controlled drug delivery systems, polymeric wound dressings, and more [2]. Modification with GA allows regulation of the biodegradation rate of chitosan [3].

For the first time, chitosan from *Apis Mellifera*, obtained from local raw materials using the cryogenic method, was synthesized, and based on it, Schiff bases with glutaraldehyde were obtained. The scientific study investigated the mechanism of interaction between chitosan and glutaraldehyde, and it was established that primarily hydrogen bonds are formed between the amino groups of chitosan and the carbonyl group of glutaraldehyde.

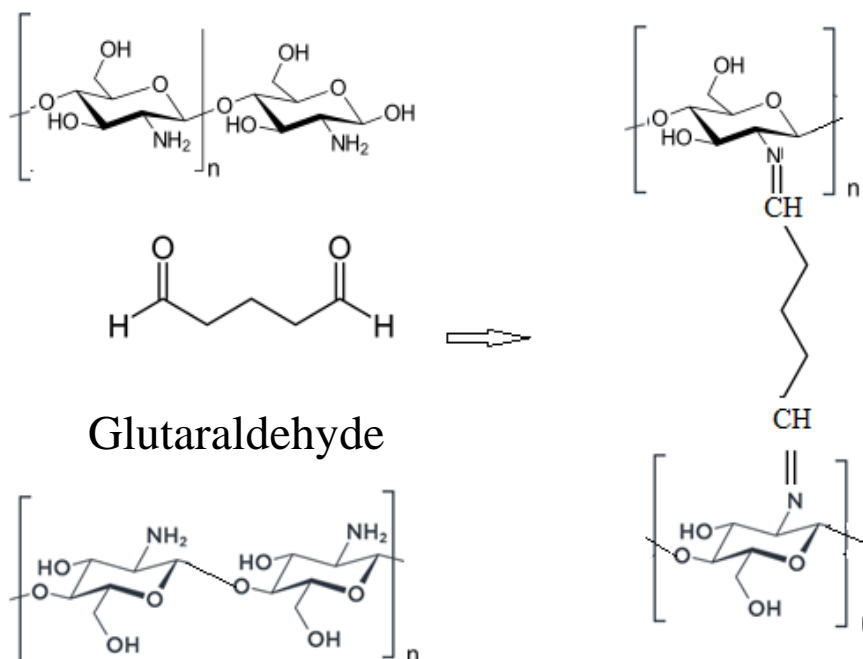

**Figure 1.** Mechanism of interaction between chitosan and glutaraldehyde.

As shown in Figure 1, a Schiff base reaction occurs between the amino group of chitosan and the carbonyl group of glutaraldehyde, resulting in the formation of an azomethine (imine) group and the release of water. One can observe the formation of primarily hydrogen bonds between the amino groups of chitosan and the carbonyl group of glutaraldehyde.

Further, the thermogravimetric properties of chitosan and its Schiff base were investigated.

The observed thermal phenomena provide insights into the stability and transitions of the Schiff base. Endothermic and exothermic effects, associated with phase changes or decomposition, can be seen at the peaks and troughs [4].

## Research Methodology

Chitosan was extracted from *Apis mellifera* (honeybee) exoskeletons using a cryogenic method (purity >85%, degree of deacetylation 75-80%).

Glutaraldehyde (GA, 25% aqueous solution, Sigma-Aldrich) was used as the crosslinking agent.

All other chemicals were of analytical grade and used without further purification.

### 1. Chitosan Purification:

- Raw chitosan was dissolved in 1% (v/v) acetic acid, filtered, and precipitated with NaOH (1M).

- The precipitate was washed with distilled water until neutral pH and lyophilized.

### 2. Schiff Base Formation:

- Purified chitosan (1 g) was dissolved in 50 mL of 2 % acetic acid under stirring.

- GA solution (2 % v/v) was added dropwise at a 1:2 molar ratio (chitosan:GA).

- The reaction proceeded at 25 °C for 24 h under a nitrogen atmosphere.

- The product was centrifuged, washed with ethanol/water (1:1), and dried at 40 °C.

Spectra were recorded (4000–400  $\text{cm}^{-1}$ , PerkinElmer Spectrum Two) to confirm imine bond formation (C=N stretch at  $\sim 1640 \text{ cm}^{-1}$ ).

TGA/DTG/DSC: Performed on a TA Instruments Q600 (25–800 °C, 10 °C/min, N<sub>2</sub> atmosphere).

### Molecular Modeling:

- Structures were optimized using HyperChem 8.0 (MM+ force field, followed by CNDO semi-empirical method).

- Charge distribution and bond polarization were analyzed in vacuum and aqueous phases.

## Analysis and Results

As seen in Figure 2, the initial mass loss of 5 % at 241 °C corresponds to the evaporation of moisture or low-molecular-weight solvent molecules from the sample.

A significant mass loss occurred in the range from 241 °C to 347 °C, accounting for 55 % of the total mass. In this temperature range, the Schiff base begins to break down, imine bonds are cleaved, and some chitosan cross-links are destroyed.

As shown in Figure 2 (B), a strong signal in the range of 212,3–394,04 °C indicates a sharp phase change associated with the degradation of the chitosan matrix via Schiff base formation. The peak at 442 °C (-0.030) marks the critical decomposition temperature, at which imine bonds are broken, leading to significant mass loss.

In the subsequent temperature stage, shown in Figure 2 (C), a gradual mass loss was observed, resulting in 40% total mass loss in the range from 347 °C to 726 °C, which includes the degradation of the chitosan polymer itself.

The troughs represent endothermic processes, while the peaks represent exothermic processes. Temperatures at 444,6 °C and above indicate significant structural changes in the Schiff base, i.e., its degradation, which points to the influence of glutaraldehyde on thermal stability [5].

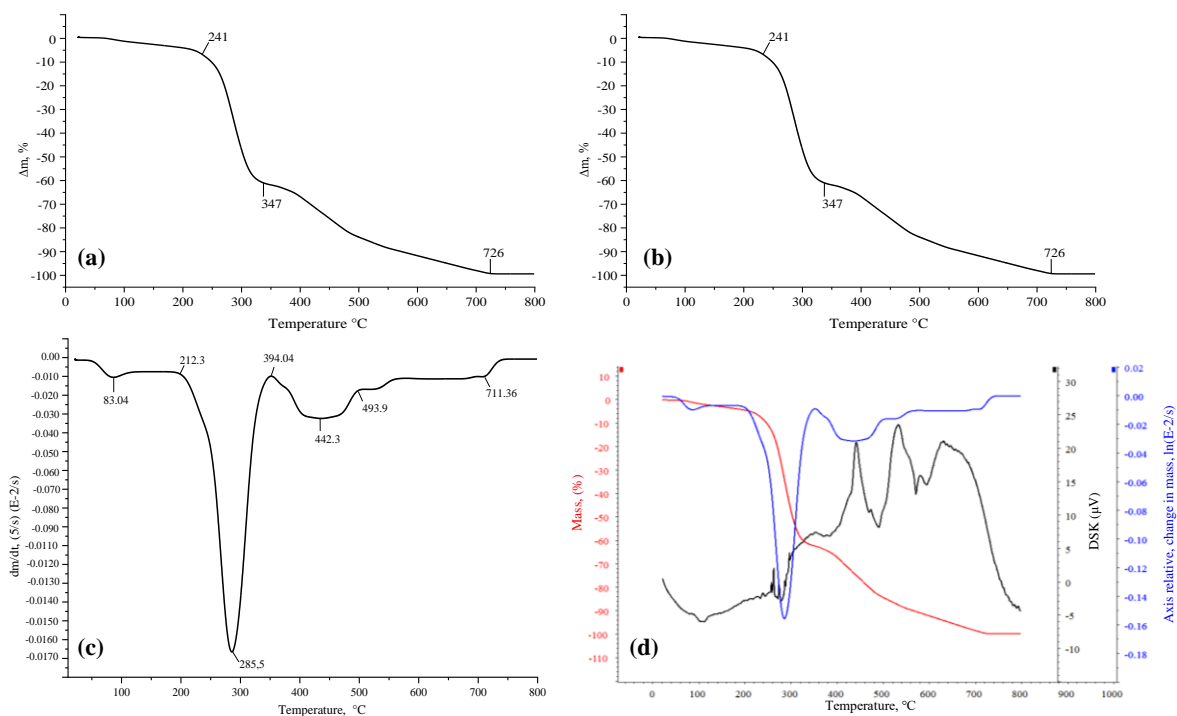

**Figure 2.** Thermogravimetric analysis (a), differential scanning calorimetric image (b) of chitosan and glutaraldehyde (c) and (d).

To confirm the reaction of chitosan with glutaraldehyde under the given conditions, the structure of the Schiff base (Xz-G) was studied using molecular modeling in the HyperChem 8.0 software. The molecular model of chitosan with glutaraldehyde is presented as Figure 3.

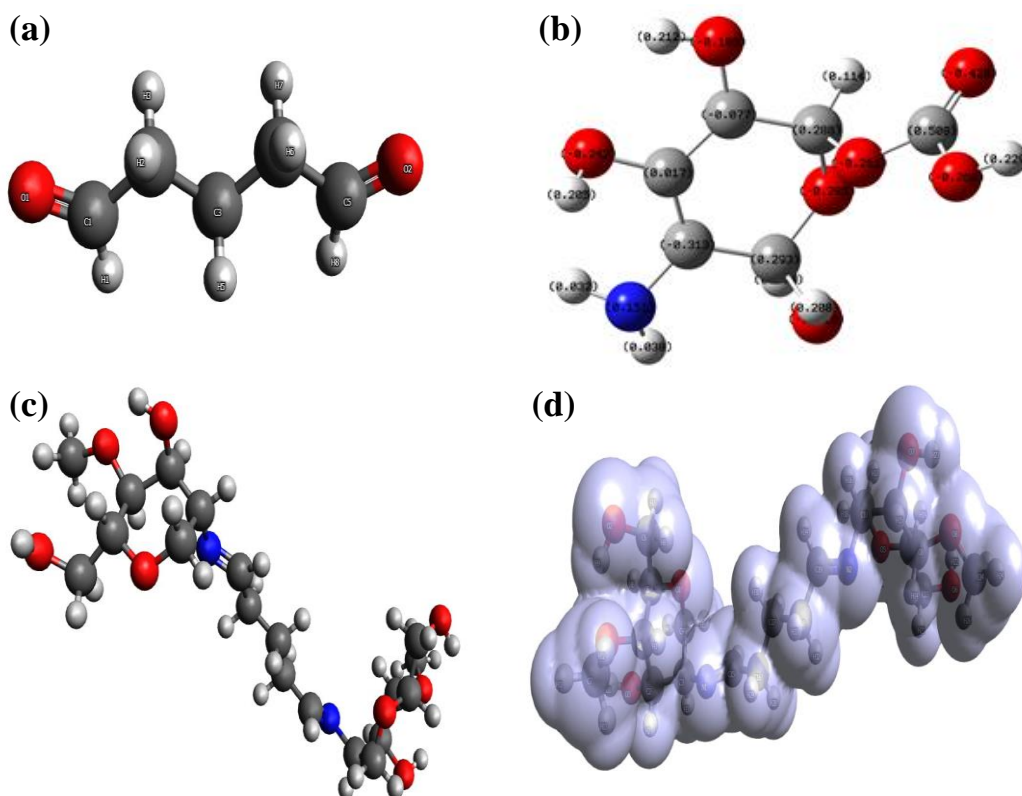

**Figure 3.** Molecular models: (a) Chitosan, (b) Glutaraldehyde, (c) and (d) Chitosan–Glutaraldehyde complex.

Accordingly, the equilibrium geometry is determined by minimizing the total energy with respect to interatomic distances. As an initial approximation, the Z-matrix of atomic coordinates was used for each molecule in the spatial model.

The electronic structure of chitosan biopolymer units and the aldehyde functional group was studied by combining molecular mechanics and semi-empirical quantum chemical calculations. A comparison was made of the geometry and distribution of partial atomic charges on monomer units, calculated using the CNDO semi-empirical method in vacuum and in aqueous solution.

Thus, the structure of the Schiff base obtained from chitosan and glutaraldehyde is characterized by the bonding of amino groups with carbonyl groups. Thermal analysis shows significant mass loss and structural changes, especially in the temperature range from 212°C to 442°C. For the structures of chitosan, glutaraldehyde, and their Schiff base, bond polarization was observed, leading to an increase in the partial positive charge on the hydrogen atom of the carbonyl group and an increase in the partial negative charge on the nitrogen atom of the amino group. This contributes to the formation of a greater number of azomethine groups [6].

## Conclusion

This study successfully synthesized and characterized a novel Schiff base complex derived from *Apis mellifera* chitosan and glutaraldehyde (GA). The interaction mechanism was confirmed through FTIR spectroscopy, revealing the formation of imine bonds (C=N) and hydrogen bonding between chitosan's amino groups and GA's carbonyl groups. Thermogravimetric analysis (TGA) demonstrated the thermal stability of the Schiff base, with significant mass loss occurring between 212–442 °C due to imine bond cleavage and polymer degradation. Molecular modeling (HyperChem 8.0) further validated the structure, highlighting charge polarization that facilitates Schiff base formation. These findings underscore the potential of insect-derived chitosan-GA complexes for biomedical and industrial applications, particularly in drug delivery and wound healing, due to their tunable biodegradation and thermal properties. Future work should explore biological activity and optimization for specific applications.

## References:

- [1] Kildeeva N.R., Perminov P.A., Vladimirov L.V., Novikov V.V., Mikhailov S.N. "On the mechanism of the reaction of glutaraldehyde with chitosan," *Bioorganic Chemistry*, T. 35, № 3, 2009, pp. 397–407.
- [2] Knaul J., Hudson S., Creber R. "Crosslinking of chitosan fibers with dialdehyds: proposal of new reaction mechanism," *Journal.Polymer*, Vol. 37, 1999, pp. 1079-1094.
- [3] Djameela S.R., Jayacrishnan A. "Glutaraldehyde cross-linked chitosan microspheres as a long acting biodegradable drug delivery vehicle," studies on the in vitro release of mitoxantrone and in vivo degradation of microspheres in rat muscle, *Biomaterials*. Vol. 16, 1995, pp. 769-775.
- [4] Ikhtiyarova G.A., Ulashov Sh. "Study of the interaction of chitosan aminopoly-saccharide of *Apis Mellifera* with glutaraldehyde," *Composition materiallar ilmiy-technical va amaliy journal*. № 1, Tashkent-2024, pp. 30-33.
- [5] Ikhtiyarova G.A., Mengliev A.S. "Selection of chitosan by cryogenic method from bee deaths and synthesis of schiff base based on salicylaldehyde and its use in fabric dyeing," *Proceeding*



*X International Conference “Industrial Technologies and Engineering” ICITE – 2023, Volume I, ISSN 2410-4604, 2023, pp. 280-284*

- [6] Ikhtiyarova G.A., Ulashov Sh. “Study of the physicochemical properties of the Schiff base based on chitosan *Apis mellifera* and glutaraldehyde,” *Scientific and technical journal FerPI*. ISSN 2181-7200, Vol. 28, № 4, 2024, pp. 239-243.

UDC: 9, 91, 910.2

## CREATION OF A WATER CADASTRE GEOPORTAL FOR THE KASHKADARYA REGION BASED ON GIS TECHNOLOGIES

**Ibragimov Lazizbek Toshpulat Ugli**

*Senior Lecturer, Independent Researcher (PhD), Samarkand State University of Architecture and Civil Engineering*  
[Ibragimov.lazizbek@samdaqu.edu.uz](mailto:Ibragimov.lazizbek@samdaqu.edu.uz)

**Аннотасија.** Ushbu ilmiy maqolada geofazoviy ma'lumotlarni qayta ishlash va ularni tahlil qilish vositalarini takomillashtirish, suv kadastrini yuritish va suv resurslaridan foydalanish sohasiga axborot-kommunikasiya texnologiyalarini keng joriy etish va geoaxborot texnologiyalaridan foydalanilgan holda Qashqadaryo viloyatining suv kadastrini geoportalini ishlab chiqish to'g'risidagi ilmiy tadqiqot natijalari bayon qilingan.

**Калит со'злар:** *GIS texnologiyalari, geofazoviy ma'lumotlarni qayta ishlash, Suv kadastrini, ArcGIS online, geoportal, ArcGIS Pro, ArcGIS Enterprise.*

**Аннотация.** В данной научной статье представлены результаты исследований по совершенствованию инструментов обработки и анализа геопространственных данных, внедрению информационно-коммуникационных технологий в ведение водного кадастра и использование водных ресурсов, а также разработке геопортала водного кадастра Кашкадарьинской области с использованием геоинформационных технологий.

**Ключевые слова:** *ГИС-технологии, обработка геопространственных данных, водный кадастр, ArcGIS Online, геопортал, ArcGIS Pro, ArcGIS Enterprise.*

**Abstract.** This scientific article presents the results of research on improving tools for processing and analyzing geospatial data, the implementation of information and communication technologies in water cadastre management and the use of water resources, as well as the development of a water cadastre geoportal for the Kashkadarya region using geoinformation technologies.

**Keywords:** *GIS technologies, geospatial data processing, water cadastre, ArcGIS Online, geoportal, ArcGIS Pro, ArcGIS Enterprise.*

### Introduction



The effective use of GIS technologies is one of the key factors in the efficient management of natural resources. In today's world, representing every natural geographical process, event, and phenomenon, along with their spatial location and time parameters, and delivering this information to users promptly has become an essential task.

The continuous improvement of tools for processing and analyzing geospatial data allows their application not only in the field of information technology but also in various scientific and technical disciplines, including the management of the water cadastre.

## Literature Review

A review of scientific literature on the subject reveals that research on water cadastre management has been conducted by foreign scientists such as L.M. Crenganis, Wolfgang Effenberg, M. Mika, M. Siejka, P. Len, Z. Krol, O. Petrakovska, A.A. Minina, A.G. Boroviska, V.P. Sedyakin, Yu.G. Shkolnaya, A.V. Yershov, V. Narimanyan, A.N. Kolobayev, V.I. Buchurin, I.S. Shkatulov, R.A. Terexova, V. Ivanov, A.A. Piskun, and M.V. Tretyakov.

In Uzbekistan, research on the efficient use of water resources, assessment of aquatic ecosystems, protection of water resources, and cadastre management based on quality and quantity indicators has been carried out by local scholars such as E.I. Chembarisov, V. Duxovniy, Sh.O. Murodov, F. Hikmatov, A.A. Rafiqov, V.E. Chub, A.N. Nigmatov, Q.S. Yarashov, S.R. Shodiyev, B.T. Kurbanov, N.I. Sabitova, A.S. Pulatov, Z.A. Amanbayeva, R. Yusupov, K.R. Rakhmonov, J.B. Gerts, X.T. Tuxtayeva, J.A. Mirzayev, A. Fozilov, and others.

However, these studies have not comprehensively explored the ecological and geographical challenges of assessing and managing the water cadastre using GIS technologies based on satellite data. Therefore, this dissertation research specifically focuses on investigating the ecological and geographical characteristics of water resource assessment and cadastre management using GIS technologies.

## Research Methodology

The implementation of information and communication technologies in water cadastre management and the use of water resources plays a crucial role in digitizing all stages of water resource utilization. This process enables the provision of real-time data to users through an online system. The development of a water cadastre geoportal for the Kashkadarya region is one of the key tasks aimed at enhancing decision-making efficiency and integrating modern geoinformation technologies.

Based on the conducted research, a geoportal for the Kashkadarya region's water cadastre was developed using modern geoinformation technologies to improve data management and facilitate prompt decision-making. Open-source software, specifically ArcGIS Online, was used as the primary platform for developing the geoportal.

The main advantages of using ArcGIS Online for the creation of the geoportal include:

The software's open-source nature, allowing any user to view, study, and contribute to its development.

No requirement for a special license, leading to cost-effectiveness and economic efficiency.

Before creating the water cadastre geoportal, the database was exported to GIS, and the coordinate system was selected. The spatial data of the studied area was digitized based on a unified conceptual framework, ensuring the formation of spatial and attribute databases simultaneously.

The geoportal's geographical foundation is based on spatial data analysis, including hydrography, hydraulic structures, relief, changes in surface water bodies, groundwater conditions, vegetation, soil characteristics, and other relevant elements.

## Analysis and Results

To develop the water cadastre geoportal, an initial database was created based on existing cartographic materials, tables, and reports. Hydrographic networks, such as rivers, lakes, canals, and collectors, along with control wells for groundwater monitoring, were included in the system.

The collected data consisted of surface and groundwater flow rates, groundwater levels, mineralization levels, and hydrochemical indicators. Raster (paper-based) maps were georeferenced using ArcGIS Pro, and control wells were digitized by creating a point layer with attribute tables. The names of the wells were assigned to the map, and data from Excel tables were analyzed to integrate selected columns into the GIS system. A shapefile attribute table was created with columns for each month (e.g., y 24\_01) to structure the data appropriately.

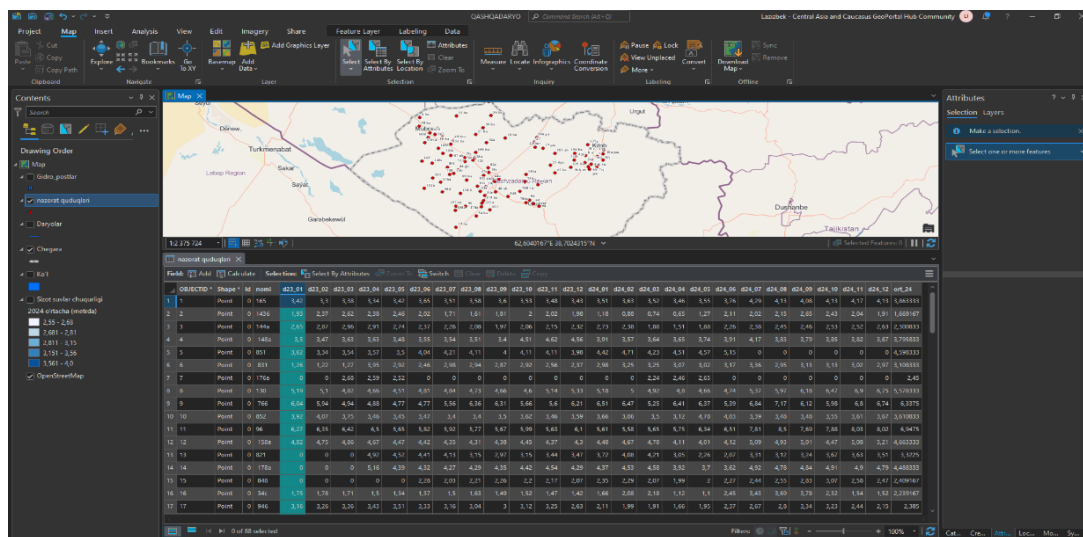

Figure 1. The process of digitizing groundwater monitoring wells in the geoportal.

Once the control well data was prepared, the regional boundaries of Kashkadarya province and its districts were obtained from open sources and digitized. Major rivers and lakes were also digitized, and all data were checked and systematically stored in an organized format.

The ArcGIS Online geoportal offers users several key functionalities, including:

*Data visualization and interactivity:* Users can explore data through interactive maps, tables, and dashboards.

*Real-time updates:* The system allows continuous monitoring and real-time data updates, making it suitable for tracking water resources.

Customizable dashboards: Users can integrate multiple visualization components such as maps, charts, tables, and key indicators to make informed decisions.

*Flexibility and adaptability:* The geoportal is suitable for various applications, including natural resource management, emergency response, public health, and logistics.

*Integration with other ArcGIS platforms:* The geoportal is fully compatible with ArcGIS Pro and ArcGIS Enterprise, allowing users to merge external datasets and enhance analytical capabilities.

Through ArcGIS Dashboards, users can interact with maps and analyze spatial trends. Clicking on a district highlights the relevant area, while selecting a hydro-post or well displays historical water consumption, groundwater levels, and mineralization conditions over time.

As a result of the conducted research, geographic, statistical, and monitoring dashboards for the Kashkadarya region were integrated, and the data was consolidated within the geoportal. The databases created in ArcGIS Pro were systematically organized, stored, and verified. Each layer (shapefile) was uploaded to ArcGIS Online using the "Share as Web Layer" function.

The names and locations of monitoring points were added to the map, and adjustments were made to layer colors to improve visualization and user accessibility.

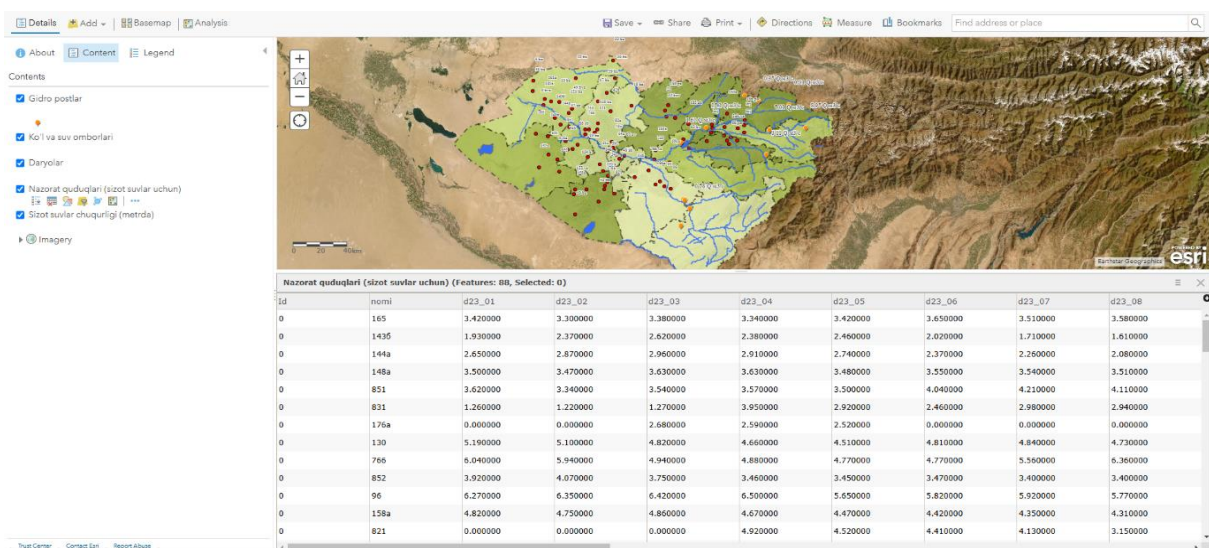

Figure 2. Adding groundwater monitoring wells.

Pop-up windows were configured to display relevant information when clicking on a monitoring well. In the ArcGIS Dashboards section, a new dashboard was created, integrating an interactive Map widget linked to the web map. The Bar Chart widget was used to visualize mineralization levels and groundwater depth, along with conditional symbols.

The results of the conducted research led to the development of an advanced geoportal that allows real-time monitoring and analysis of water resources. (<https://cacgeoportalnhub.maps.arcgis.com/apps/dashboards/44bd660b58f346509bf1697318448f11>) water cadastre geoportal, clicking on a district name highlights the corresponding area. Clicking on a hydropost displays annual water consumption over

different years. Additionally, selecting a monitoring well provides detailed information on groundwater levels, infiltration water levels, and mineralization levels over time.

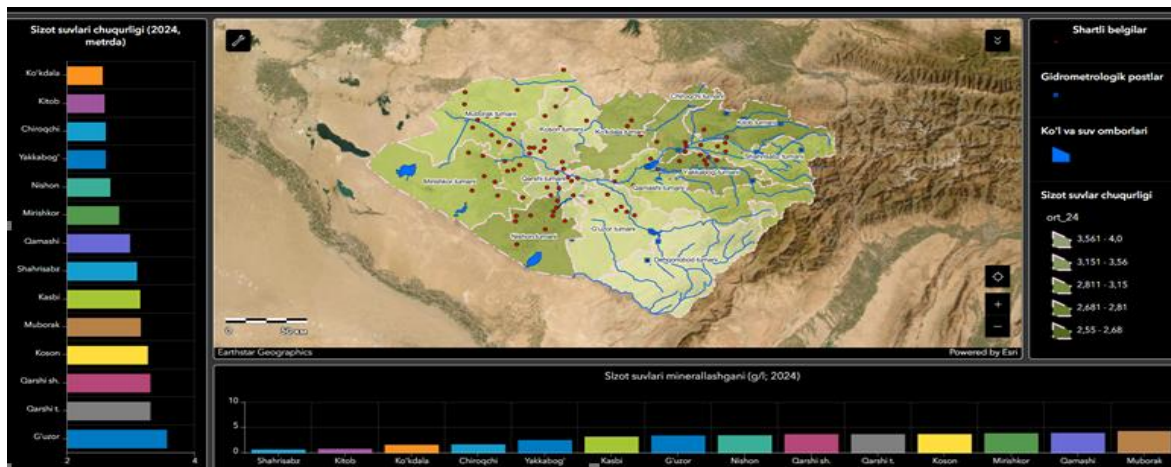

Figure 3. Water Cadastre Geoportal Interface.

This interactive functionality enhances data accessibility and decision-making for water resource management.

## Conclusion

The water cadastre geoportal for Kashkadarya region, developed in ArcGIS Online, enables the analysis and visualization of long-term surface water consumption, groundwater levels and composition, and the condition of infiltration groundwater.

The geoportal displays the locations of monitoring wells, along with groundwater and infiltration water levels and their hydrochemical properties, providing a comprehensive tool for water resource management and assessment.

## References:

- [1] Law of the Republic of Uzbekistan "On State Cadastres," № 171-II, dated December 15, 2000.
- [2] Decree of the President of the Republic of Uzbekistan "On approval of the Environmental Protection Concept of the Republic of Uzbekistan for the period until 2030" № PF-5863, dated October 30, 2019.
- [3] Crenganis L.M. "The use of gis in water cadaster," *RevCAD Journal of Geodesy and Cadastre*. Romania. 2013, pp. 69-74.
- [4] Effenberg W.W., Enemark S. and Williamson I.P. "Framework for Discussion of Digital Spatial Data Flow within Cadastral Systems," *The Surveyor*. Australia. 1999, pp. 35-43.
- [5] Mika M., Siejka M., Len P., Krol Z. "The concept of using the water cadastre databases components for the construction of multi-dimensional cadastre in Poland," *Survey Review*, Volume 50, UK. 2018, pp. 209-211.
- [6] Petrakovska O. "Features of cadastral accounting and monitoring of water facilities in Ukraine," *Journal of Transfer of innovative technologies*, № 1, Ukraine, 2018, pp. 26-35.
- [7] G'ulomova L.X., Safarov E.Yu., Abdullayev I.O'. "Geoinformation systems and technologies," (parts 1-2) – T.: University, 2013, p. 130.
- [8] Yarmatova D.S., Bobojonov A.R., Raximov A.R. "Fundamentals of the State Cadastre," Textbook. Tashkent: *Cholpon National Institute of Cadastre*. 2014, p. 238.
- [9] Wolf P.R. "Elements of photogrammetry," *McGraw Hill Education* (India) 2014, p. 562.
- [10] Safarov E.Yu., Prenov Sh.M., Allanazarov O.R., Sayidov A.K., Raxmonov D.N. "Cartography and geovisualization," T.: *Economics Finance*, 2016, p. 230.





UDC: 9, 91, 910.2, 929

## CREATION OF DESERT AGROPHYTOCENOSES ON THE DRIED BOTTOM OF THE ARAL SEA

**Zinoviy Bogdanovich Novitsky**

*Doctor of Agricultural Sciences, academician  
RANS and IAINI, Honored worker of agriculture  
of the Republic of Uzbekistan and the Republic of  
Karakalpakstan, Head of the laboratory of  
protective afforestation and forest melioration of  
the Research Institute of Forestry  
[zinoviy.novitskiy@mail.ru](mailto:zinoviy.novitskiy@mail.ru)*

**Annotatsiya.** Ishning maqsadi Orol dengizi qurigan tubining tub cho'kindilarining o'rmon barpo qilish mumkin bo'lgan maydonlarida cho'l o'simliklari agrofittosenozini yaratishning eng samarali usullarini ishlab chiqish va yaratilayotgan yaylovlarning mahsuldorligini oshirish uchun cho'l yem-xashak o'simliklarini tanlashdan iborat. Aniqlanishicha, Orol dengizining qurigan tubida yaylovni muhofaza qilish va meliorativ yem-xashak o'simliklari, shuningdek, chogon, teresken, boyalich, keyreuk kabi yem-xashak o'simliklarini qo'llash orqali 1 gektar maydondan 500 sentener ozuqa birligi olish mumkin. Bu yaylovda boqiladigan hayvonlarning sonini 20-30 foizga oshirish imkonini beradi.

**Kalit so'zlar:** *Yaylovlar, agrofittosenoz, ekish, urug', qurigan tub, tur, namlik, mahsuldor zahira.*

**Аннотация.** Целью работы являлось - разработка наиболее эффективных методов создания пустынных агрофитоценозов на лесопригодных типах донных отложений осушенного дна Аральского моря и подбор пустынных кормовых растений для повышения продуктивности создаваемых пастбищ. Установлено, что при применении очагового, пастбищезащитного и мелиоративно-кормового методов, а также таких кормовых растений, как чогон, терескен, боялыч, кейреук на осушенном дне Арала можно создать пастбища с кормовой емкостью до 500 кормовых единиц с 1 гектара. Это позволит увеличить количество выпасаемых животных на 20-30 %.

**Ключевые слова:** *пастбища, агрофитоценоз, посев, семена, осушенное дно, типы, влажность, продуктивный запас.*

**Abstract.** The aim of this study was to develop the most effective methods for establishing desert pasture ecosystems on afforestation-suitable bottom sediments of the dried Aral Sea bed and to select desert forage plants to enhance pasture productivity. It was established that when using focal, pasture-protective reclamation-forage methods, as well as such forage plants as chogon, teresken, boyalich, keyreuk on the dried bottom of the Aral Sea, it is possible to create pastures with a forage capacity of up to 500 forage units per 1 ha. This approach could lead to a 20-30% increase in grazing livestock numbers.

**Keywords:** *pastures, agrophytocenosis, sowing, seeds, dried bottom, types, humidity, productive reserve.*



## Introduction

On the dried-up bed of the Aral Sea, the low percentage of forest cover contributes to wind erosion, which hinders the natural regeneration of pasture plants, results in low pasture productivity, and leads to the complete or partial degradation of the land.

## Literature Review

According to the conclusions of two UN Secretaries-General, Ban Ki-moon and António Guterres, the situation surrounding the Aral Sea is of global significance. In addition to the need for afforestation and reclamation of the dried-up seabed, there is also a necessity to incorporate it into economic use by creating desert agro-phytocenoses, i.e., pastures. Establishing additional pastures on irrigated lands is a challenging task, as these lands are used for cultivating other strategically important agricultural crops for the state. Moreover, irrigating additional pastures is becoming increasingly difficult each year due to a severe water shortage [1, 8].

Until today, the development of livestock farming was carried out by utilizing previously unused pasture areas, but this reserve has now been exhausted. However, Uzbekistan has another potential resource for creating pastures—the bottom sediments suitable for afforestation on the dried-up bed of the Aral Sea. Many people believe that the dried seabed consists entirely of sand and salt flats, but this is not the case. Non-afforestation-prone types of bottom sediments cover approximately 35% of the area, while the land suitable for establishing desert pastures amounts to 1.5 million hectares [2, 9]. On such areas, pastures can be created with a productivity of 400-500 feed units per hectare. In the future, this region could become a supplier of fodder for the Aral Sea region, which has been designated as a zone of ecological innovation and technology.

## Research Methodology

The research was conducted on afforestation-prone types of bottom sediments on the dried-up bed of the Aral Sea from 2012 to 2023. The study focused on the technology of creating desert pastures, selecting a range of fodder plants, and assessing the productivity of the established agro-phytocenoses. The work was carried out as part of state programs for scientific research projects: KHI – 5 – 012 – 2016; KHA – 7 – 026 – 2015; KH – A – KH – 2018 – 110; I-BV-KH-2019-4. The objects of the study were types of bottom sediments with salinity levels of no more than 0.04% (in terms of chlorine) and a granulometric composition classified as sandy loam and loamy soil substrates.

The methods for creating desert shrub pastures included pasture-protective, reclamation-fodder, and focal forest plantations.

The selection of fodder plants consisted of the following species: *Ceratoides latens* (teresken gray), *Aellenia subaphylla* (chogon), *Salsola orientalis* (keyreuk), *Salsola arbuscula* (boyalych), and *Kochia prostrata* (izen). Additionally, the primary forest-forming species was *Haloxylon aphyllum* (black saxaul). Soil treatment was carried out using a chisel plow mounted on a T-150K tractor, followed by seed sowing or planting of one-year-old seedlings. The aforementioned desert fodder plants, which form the basis of the created pastures, were tested in the study.

No targeted scientific research had previously been conducted to test the feasibility of growing an expanded range of fodder plants on the dried-up bed of the Aral Sea for the purpose of creating a desert pasture agro-phytocenosis. Therefore, this study was carried out for the first time. In the spring of 2015, a series of experiments was initiated to establish desert pasture agro-phytocenoses involving two or more species of fodder plants [3, 10]. The experiment was designed as a statistical study involving the sowing of forage plant seeds. Throughout the entire growing season, soil moisture was monitored, and biometric measurements of emerging plant seedlings were conducted.

## Analysis and Results

It is well known that soil moisture has a significant impact on plant growth and development, especially during the first year. In young plants, the still underdeveloped root system is located within the top 15 cm of soil, making moisture in this layer particularly crucial. Before sowing the seeds, the soil was treated with a chisel plow, and moisture levels were studied monthly using the thermostat-weight method, both in the control plots and in soil treated with the chisel plow.

**Table 1.** Soil Moisture Content (%) in Experimental Variants for the Creation of Pasture Agro-Phytocenoses (2015).

Soil Horizon Depth (cm)	Months of Study				
	April	May	June	July	September
Variant with Chisel-Treated Soil					
0 - 5	6.80	3.60	2.56	1.98	1.12
6 - 10	7.34	5.06	3.45	2.21	1.75
11 - 20	10.08	8.38	6.12	3.24	2.22
21 - 40	21.77	22.40	17.65	15.46	12.41
41 - 60	26.60	28.93	26.71	23.45	22.34
Dried Seabed Without Soil Treatment (Control)					
0 - 5	5.43	2.77	2.21	1.78	1.12
6 - 10	6.10	4.10	3.42	2.36	1.76
11 - 20	8.75	7.31	5.41	3.42	2.23
21 - 40	20.95	21.45	17.64	15.41	12.54
41 - 60	26.10	27.98	23.45	21.29	17.68

In May 2015, 70.9 mm of precipitation fell, which is almost the average annual norm. This allowed the soil moisture in the 0-20 cm horizon to range from 3.60% to 8.38% (Table). In April, the soil moisture in the 0-5 cm horizon was 6.80%, but by the end of the growing season in September, it had dropped to just 1.12%. The year 2015 was favorable for seed germination and the emergence of uniform fodder plant seedlings in the agro-phytocenosis. However, in June and July, extreme heat was observed, with air temperatures reaching 50°C, while the ground surface temperature exceeded 60°C. This led to the scorching of the still-fragile leaves of *Ceratoides latens* (teresken) and other fodder plant species. Despite the leaf burn, the root systems of the seedlings remained viable.

In September, as part of the autumn assessment of the number of plants that survived the summer heat, we conducted excavations of the root systems of *Aellenia subaphylla* (chogon) and *Ceratoides latens* (teresken). The root systems of 22 model plants were

studied. It was found that, on average, roots from seed germination extended 15-17 cm deep and spread 10-12 cm horizontally. The summer heat did not have a detrimental effect on the root systems. They remained viable, and with the additional moisture from winter-spring precipitation, they resumed their biological development.

Our experimental studies have shown that the most favorable conditions for the growth of fodder plants on the sandy loam plains of the dried-up Aral Sea bed are found in *Ceratoides latens* (teresken) and *Aellenia subaphylla* (chogon), while conditions are less favorable for *Salsola arbuscula* (boyalych) and *Salsola orientalis* (keyreuk). In the chogon-teresken agro-phytocenosis, an average of  $45 \pm 1.08$  plants per  $1 \text{ m}^2$  were recorded, whereas in the boyalych-keyreuk agro-phytocenosis, only 2 plants per  $\text{m}^2$  were observed. To establish desert shrub pastures, it is advisable to create multi-species agro-phytocenoses, such as chogon-keyreuk-boyalych-teresken agro-phytocenoses, where an average of  $44.6 \pm 2.17$  plants per  $1 \text{ m}^2$  can be achieved. This approach would allow for the development of productive pastures by the 4th or 5th year, with a carrying capacity of up to 500 feed units per hectare.

The determination of forage mass reserves in an air-dry state in the above-mentioned experimental variants in September 2017 showed the following pasture capacities: chogon-teresken agro-phytocenosis –  $562 \pm 12.4$  kg/ha, boyalych-keyreuk agro-phytocenosis –  $118 \pm 4.7$  kg/ha, Saxaul-chirkez agro-phytocenosis –  $285 \pm 7.9$  kg/ha, Chogon-keyreuk-boyalych-teresken agro-phytocenosis –  $522 \pm 12.7$  kg/ha. As seen from the experimental data, despite the extreme heat in the first year, which damaged the above-ground biomass, the surviving root systems allowed the plants to recover by utilizing moisture accumulated during the winter-spring period. This enabled the formation of pastures with a good forage mass reserve by the third year of growth [4, 6].

The placement of protective forest belts depends on the wind activity in the area. The weaker the wind regime, the greater the distance between the belts, ranging from 90 to 120 meters. In areas with strong wind activity, the distance between the belts is reduced to 30-50 meters. The belts are established in three rows, and in the spaces between them, seeds of fodder plants such as chogon (*Aellenia subaphylla*), teresken (*Ceratoides latens*), boyalych (*Salsola arbuscula*), keyreuk (*Salsola orientalis*), izen (*Kochia prostrata*), and others are sown.

On the dried-up bed of the Aral Sea, fodder reclamation strips have become widespread. These strips can be located both in the inter-strip spaces between protective forest belts and in open areas. Such strips are primarily composed of fodder plants and are placed in inter-strip spaces with a distance of 20 meters between them, allowing for 3-4 strips in these areas. In open areas of the dried seabed, fodder reclamation strips are placed every 10 meters. Within 2-3 years, the fodder plants reach the fruiting stage, and their seeds are dispersed by the wind, gradually populating the inter-strip spaces and forming enriched desert pastures. Research has shown that by the third year after the establishment of fodder reclamation strips, natural seed dispersal resulted in an average of 6-8 plants per  $1 \text{ m}^2$  in the inter-strip spaces [5, 7].

The establishment of forest and fodder plantations plays a crucial role on the dried-up bed of the Aral Sea, where vegetation is extremely sparse. This is especially



important today, as the massive release of carbon dioxide into the atmosphere and the corresponding decline in oxygen levels contribute to global climate warming.

## Conclusion

1. Based on the research results, it can be concluded that desert pasture agrophytocenoses can be successfully established on forest-suitable bottom sediments of the dried-up Aral Sea bed using a wide range of fodder plants.

2. To achieve this goal, it is advisable to apply the focal method for pasture creation, along with pasture-protective and reclamation-fodder afforestation methods.

3. This approach will help: stabilize the dried seabed and prevent soil particle deflation, increase the fodder productivity of the area, and expand grazing capacity, allowing a 20-30% increase in the number of livestock.

## References:

- [1] Bakirov N.Zh., Novitsky Z.B., Khamzaev A.Kh. "Forest plantations on the dried bottom of the Aral Sea," *J. Forest Journal* 2/374. Arkhangelsk, (news of higher educational institutions), 2020, pp. 51-59.
- [2] Bakirov N.Zh., Novitsky Z.B., Khamzaev A.Kh., Auezov F.K. "Ecological role of forest plantations on the dried bottom of the Aral Sea," *J. AGRO ILM*, № 4 (67), 2020, pp. 83-85.
- [3] Bakirov N.Zh., Khamzaev A.Kh., Novitsky Z.B., Auezov F.K. "Innovative methods of afforestation of the dried bottom of the Aral Sea," *J. AGRO ILM*, № 5 (68), 2020, pp. 67-69.
- [4] Bakirov N.Zh., Khamzaev A.Kh., Novitsky Z.B., Atajanova G.Kh. "Creation of pastures by the coulisse method on the dried bottom of the Aral Sea," *J. AGRO ILM*, № 11, 2020, pp. 82-83.
- [5] Novitsky Z.B. "Recommendations on methods for creating pastures on the dried bottom of the Aral Sea," Tashkent, 2014, p. 24.
- [6] Novitsky Z.B. "Recommendations for the creation of desert pasture agrophytocenoses on the dried bottom of the Aral Sea," Tashkent, 2017, p. 18.
- [7] Novitsky Z.B. "Recommendations for the creation of pastures from forage plants on weakly overgrown sandy deposits subject to deflation processes on the dried bottom of the Aral Sea," Tashkent, 2020, p. 21.
- [8] Novitsky Z.B. "Seed production on the Aral," *J. Xorazm Mamun Akademiyasi Axborotnomasi*. Khiva -2025, pp. 223 - 226.
- [9] Novitsky Z.B. "Green shield of the dried bottom of the Aral Sea," *J. Fan va Turmush*, № 2, 2024, pp. 16-19.
- [10] Novitsky Z.B., Atajanova G.Kh. "The path to improving the Aral zone and desert territories," *J. Agriculture of Uzbekistan*, № 8, 2024, pp. 27-28.



UDC: 94, 172, 177, 304

## SOME REFLECTIONS ON THE STAGES OF URBANIZATION PROCESSES IN THE KHOREZM OASIS DURING ANCIENT AND EARLY MEDIEVAL PERIODS

**Babajanova Nilufar Alisherovna**

*Teacher, Department of History, Urgench State*

*University named after Abu Rayhan Biruni*

*nilufarbabajanova01@gmail.com*

**Annotatsiya.** Ushbu tadqiqot janubiy Orolboʻyida miloddan avvalgi VI asrdan boshlab ijtimoiy-iqtisodiy va etnikmadaniy taraqqiyotni oʻrganadi. Miloddan avvalgi IX-asrgacha Amudaryoning oʻng va chap qirgʻoqlaridagi aholi punktlariga alohida eʼtibor qaratilgan. Arxeologik topilmalar shuni koʻrsatadiki, erta urbanizatsiya Ahamoniylar taʼsirida shakllangan, soʻngra mustaqil Xorazm ekspansiyasi boshlangan. Hidrologik oʻzgarishlar, xususan, Amudaryo oqimining siljishi aholi punktlarining barqarorligiga sezilarli taʼsir koʻrsatib, oʻng qirgʻoq markazlarining tanazzulga uchrashiga olib keldi, Xiva va Xazarasp kabi chap qirgʻoq markazlari esa barqaror sugʻorish tufayli saqlanib qoldi. Tadqiqot mintaqaviy tarixni shakllantirishda atrof-muhit omillari va inson faoliyatining oʻzaro taʼsirini taʼkidlaydi.

**Kalit soʻzlar:** *Xorazm, Amudaryo, urbanizatsiya, irrigatsiya, ijtimoiy-iqtisodiy munosabatlar, Ahamoniylar, arxeologik tadqiqotlar.*

**Аннотация.** В этом исследовании рассматривается социально-экономическое и этнокультурное развитие в регионе южного Аральского моря с VI века до н. э. по IX век н. э., уделяя особое внимание поселениям вдоль правого и левого берегов Амударьи. Археологические находки показывают, что ранняя урбанизация была сформирована влиянием Ахеменидов, за которым последовала независимая экспансия Хорезма. Гидрологические изменения, в частности сдвиги в течении Амударьи, значительно повлияли на устойчивость поселений, что привело к упадку центров правого берега, в то время как левобережные центры, такие как Хива и Хазарасп, выстояли благодаря стабильному орошению. В исследовании подчеркивается взаимодействие между факторами окружающей среды и деятельностью человека в формировании региональной истории.

**Ключевые слова:** *Хорезм, Амударья, урбанизация, ирригация, социально-экономические отношения, Ахемениды, археологические изыскания.*

**Abstract.** This study examines the socio-economic and ethno-cultural development in the southern Aral Sea region from the 6<sup>th</sup> century BCE to the 9<sup>th</sup> century CE, focusing on settlements along the Amu Darya's right and left banks. Archaeological findings reveal that early urbanization was shaped by Achaemenid influence, followed by independent Khorezmian expansion. Hydrological



changes, particularly shifts in the Amu Darya's flow, significantly impacted settlement sustainability, leading to the decline of right-bank centers while left-bank hubs like Khiva and Khazarasp endured due to stable irrigation. The study highlights the interplay between environmental factors and human activity in shaping regional history.

**Keywords:** *Khorezm, Amu Darya, urbanization, irrigation, socio-economic relations, Achaemenid, archaeological survey.*

## Introduction

The article highlights the factors influencing the development of socio-economic and ethno-cultural relations within society in the southern Aral Sea region from the late Iron Age to the 9<sup>th</sup> century CE. The study is based on the results of extensive archaeological research conducted by members of the Khorezm Expedition in residential areas on the right and left banks of the Amu Darya and the lower Syr Darya basin. The information recorded in various scientific literary works, articles, and research seminar collections serves to illuminate the content and essence of this article.

## Literature Review

The geological foundation of the Eurasian region is uniform, but its surface is diverse, and the distribution of the population has not been unified across geographical expanses, a process tied to the dynamics occurring underground.

In archaeological literature, the history of the land we inhabit is estimated to span five billion years, with the most recent stage, the Cenozoic era, dating back 60–70 million years. The Cenozoic era is divided into the Paleogene, Neogene, and Anthropogene stages. The Anthropogene stage corresponds to the period of human activity and is further divided into the Eopleistocene, Pleistocene, and Holocene periods. From the Neogene to the Eopleistocene periods, specifically during the Günz-Mindel periods, the region was a plain [1, 2] approximately 500,000 years ago, following the Eopleistocene period, natural temperatures began cooling, leading to the Mindel-Würm period. The Pleistocene glaciation covered the region, marking the end of the great glacial period. The rise in natural temperatures, accompanied by the retreat of glaciers northward, led to the formation of new humid and semi-humid areas, associated with the Holocene period [3].

According to achievements in geographical science, between 25–10 million years BCE, the Kyzylkum-Aral depression and the Karakum-Ustyurt plateau regions were plains [4]. In P. Baratov's geography textbook, the territory of Uzbekistan is divided into several natural-geographical regions, one of which is the Khorezm Oasis plain [5].

Currently, the local population conducts its daily activities in two regions, a process linked to the northward flow of the Amu Darya River around during the 8<sup>th</sup> –7<sup>th</sup> millennia BCE, influenced by the activity of sloped terrains.

Research by the Khorezm Expedition members indicates that in the regions of the right and left banks of the Amu Darya, between the sand dunes of Kyzylkum and Karakum, depressions turned into water basins due to the rising water level of the Amu Darya. Populations settled on the hills adjacent to these basins, initially living on artificially leveled ground and later in semi-underground dwellings, continuing their daily activities until the end of the 6th century BCE [6-9].

Archaeological excavation results indicate that urban processes took place in the southern part of the Khorezm Oasis, specifically in the middle section of the left bank of the Amu Darya, during the 9<sup>th</sup> –8<sup>th</sup> centuries BCE. Excavations conducted by V.N. Pilipko at these elevations uncovered artifacts dating to the late 9<sup>th</sup> –early 8<sup>th</sup> centuries BCE [10]. In our view, the population of Odoytepa, in response to historical demands, gradually mastered the mineral-rich lowlands on the right and left banks of the Amu Darya, constructing fortified cities.

Between 545–539 BCE, the Shurakhon village area of the Khorezm Oasis became part of the Achaemenid Empire, marking the beginning of a history of political relations. It can be concluded that the Achaemenid state appointed a governor who initiated the construction of residential areas on the right and left banks.

From the 4<sup>th</sup> –3<sup>rd</sup> centuries BCE to the 2<sup>nd</sup> century CE, after achieving political independence, the Khorezm state prioritized the construction of villages and cities in the lower Amu Darya region and the Sariqamish area as part of its internal policy [11–13].

From the 1<sup>st</sup> century CE to the 9<sup>th</sup> century CE, in residential areas on the right and left banks of the Amu Darya, the population's economic activities faced a sharp decline in Amu Darya water levels. In the southern region of the Sultan Uveys Mountains and around the Yonboshqala elevation, an economic crisis affected all sectors in the right bank region during the first half of the 6<sup>th</sup> century CE (e.g., Ayozqala, Burliqala, Janbosqala, Quyqrilganqala). In Burgutqala, the internal area shrank from 5 hectares to 1 hectare, and in Tuproqqala, it decreased from 17 hectares to 3.47 hectares.

However, cultural life continued in Shurakhon and Katqala. On the left bank, due to stable water supply from the Charmanyob and Xeykanik irrigation systems, the decline was not as severe as on the right bank. Primarily within the cultural-economic sphere of Khiva (Tuproqqala) and Voyangan, cultural life in micro-oases ended. Major cultural-economic centers, such as Khiva, Katqala (Shovot), Zamaxshar, Qalajiq, and others, continued their economic and cultural activities, supported by a stable water supply from the Dovdon and Daryoliq tributaries of the Amu Darya. On the right bank, cities like Katta Guldursun and Katqala, and on the left bank, cities like Khiva, Xazarasp, Gurganch, Mizdaxkon, and Davkasgan, developed as administrative-territorial and trade-craft centers, laying the foundation for the progress of later societies [14, 15].

## **Research Methodology**

Scientific objectivity, historical-chronological analysis, theoretical comparison, discussion, substantiation, and the achievements of archaeology, ethnography, and geography were utilized.

## **Analysis and Results**

Based on information published by members of the Khorezm archaeology-ethnography expedition, the factors influencing the development of socio-economic and ethno-cultural relations in society from the last quarter of the 6<sup>th</sup> century BCE to the 9<sup>th</sup> century CE were analyzed.

*Following observations were noted as results.* In the last quarter of the 6<sup>th</sup> century BCE, under the influence of urbanization processes that gradually encompassed the right and left banks of the Amu Darya, the construction of cities began.

In the 5<sup>th</sup> century BCE, on the right bank, Bozorqala and Ding‘ilja, and on the left bank, Xazarasp and Khiva emerged as early cities, reflecting the construction policies of the Achaemenid state.

From the 4<sup>th</sup> century BCE to the 1st century BCE, after gaining independence from the Achaemenids, the Khorezm state extensively constructed villages and cities in the southern regions of the Kyzylkum and Karakum regions and the Ustyurt plateau.

From the 1<sup>st</sup> to the 4<sup>th</sup> centuries CE, the population constructed large cities surrounded by smaller residential areas (e.g., Angqaqala, Qurg‘oshin, Olmaotishgan-1, Bo‘ldimsoz, etc.).

In the first half of the 5<sup>th</sup> -6<sup>th</sup> centuries CE, due to interruptions in the Amu Darya water supply, the Kaltaminor, Tozabog‘yob, and Amirobod main canals did not reach their final stages, leading to the decline of monuments in the Sultan Uvays system (e.g., Burliqala, Ayoqzala-1, Bozorqala, Angqaqala, etc.).

On the right bank, economic and cultural life continued in residential areas such as Katta Guldursun near the Burgutqala citadel, Kuyukkala near the Tuproqqala citadel, and Baraktam Kat (right bank) and To‘qqala. On the left bank, cultural life persisted in areas such as Khiva, Xazarasp, Sandiqlitepa, Qalajiq, Zamaxshar, Olmaotishgan-2, Katqala, Mizdaxkon, Shoxsanam, Gurganch, and Yarbaqirqala.

From the second half of the 6<sup>th</sup> century CE to the 9<sup>th</sup> century CE, cultural life continued in the aforementioned population centers. A distinctive feature of this period was the presence of citadels in unfortified and fortified centers on plains around Burgutqala, Teshikqala, and Qumbosganqala on the right bank, with “Qo‘rg‘on” and “Qal‘a” occupying areas of 0.1–1 hectare.

## **Conclusions and Recommendations**

From the last quarter of the 6<sup>th</sup> century BCE to the 5<sup>th</sup> century BCE, the construction of residential areas of varying sizes and quantities on the right and left banks of the Amu Darya, as well as the creative activities of the sedentary population, were influenced by the activity of the Amu Darya.

During this historical period, the sedentary agricultural population mastered humid and semi-humid areas, utilizing them for their benefit. They constructed the Kaltaminor irrigation system from the Amu Darya, building residential areas at the beginning and end of its branches. As a result, cultural-economic centers such as Bozorqala and Ding‘ilja were formed on the right bank. On the left bank, in the southern regions of Khorezm, the construction of irrigation systems from the Amu Darya’s Toshshaqa led to the establishment of Xazarasp, Khiva, and cultural-economic centers in the Sariqamish basin, supported by the Dovdon tributary and the Yob irrigation system. In the middle section of the left bank of the Amu Darya, centers like Qushqala emerged.

From the 5<sup>th</sup> to the 9<sup>th</sup> centuries CE, due to interruptions in the Amu Darya water supply, activities in several cultural-economic centers ceased, and populations abandoned them (on the right bank, this process occurred in the southern region of the Sultan Uvays Mountains, around the Yonboshqala elevation, and between the Amu

Darya). On the left bank, economic and cultural relations also declined in certain micro-oases within cultural-economic spheres (e.g., Khiva Tuproqqalasi, Olmaotishgan-1, Yangiariq Tuproqqalasi, Shovot Tuproqqalasi). In this sense, the influence of the geographical environment on economic and ethno-cultural relations was more pronounced on the right bank.

From the second half of the 6<sup>th</sup> century CE to the 9<sup>th</sup> century CE, the activities of the aforementioned cultural-economic centers continued, maintaining economic and ethno-cultural relations. These centers served not only as population hubs but also as trade-craft and religious-ideological centers, with the stability of the Amu Darya water supply being a key factor.

#### References:

- [1] Avdusin D.A. "Fundamentals of Archaeology," Moscow: "Higher School," 1989, pp. 20–21.
- [2] Asqarov A. "Ethnogenesis and Ethnic History of the Uzbek People," Tashkent: "University," 2007, p. 113.
- [3] Baratov P., Mamatqulov M., Rafikov A. "Physical Geography of Central Asia," Tashkent: "Teacher," 2002, p. 283.
- [4] Baratov P. "Physical Geography of Uzbekistan," Tashkent: "O'qituvchi," 1996, pp. 157–162.
- [5] Vinogradov A.V. "Neolithic Monuments of Khorezm," Moscow: *Nauka*, Issue VIII, 1968, p. 170.
- [6] Vinogradov A.V. "Ancient Hunters and Fishermen of the Central Asian Interfluve," Moscow: *Nauka*, 1981, pp. 78-89.
- [7] Itina M.A. "History of the Steppe Tribes of the Southern Aral Region (2<sup>nd</sup>–Early 1<sup>st</sup> Millennium BCE)," Moscow: *Nauka*, Vol. X, 1977, p. 229.
- [8] Kabirov J., Sagdullaev A. "Archaeology of Central Asia," Tashkent: "Teacher," 1990, p. 14.
- [9] Shonazarov Sh.B. "Geoarchaeology," Tashkent, 2019, p. 175.
- [9] Pilipko V.N. "Excavations in the Deynau District of the Chardjou Region," In *Archaeological Discoveries of 1975*. Moscow: *Nauka*, 1976, p. 528.
- [11] Mambetullaev M. "History and Culture of Southern Khorezm in the Ancient Period (Cities and Settlements from the 4<sup>th</sup> Century BCE to the 4<sup>th</sup> Century CE)," *Abstract of Doctoral Dissertation*. Tashkent, 1994, p. 42.
- [12] Xodjaniyazov G.K. "Ancient Khorezm Defensive Structures," Tashkent: "Uzbekistan," 2007, p. 130.
- [13] Sobirov Q. "Defensive Structures of Khorezm's Villages and Cities," Tashkent: "Science," p. 166.
- [14] Qurbanov A. "Some Insights into the Economic Development of Early Medieval Society in the Lower Amu Darya Region," *Beruni, Light of Civilization*, № 4 (43), 2023, pp. 22–25.
- [15] Qurbanov A. "Economic Relations in Early Medieval Society of the Southern Aral Sea Region," *Beruni, Light of Civilization*, № 6, 2023, pp. 22–26.



UDC: 94, 669, 543.2

## RAW MATERIAL SOURCES OF BRONZE AGE SOUTH ISLAND METALLURGY INDUSTRY

**Turganov Bakhyt Gurbanbaevich**

Associate Professor, Nukus State  
Pedagogical Institute, Uzbekistan  
[turganovbaxit@gmail.com](mailto:turganovbaxit@gmail.com)

**Allamuratov Anvar Alisher Ugli**

Student, Karakalpak State University  
named after Berdakh

**Annotatsiya.** Miloddan avvalgi 2-ming yillikda O'rta Osiyoda metallurgiya faoliyatining kengayishi sezilarli siljish bo'lib, ishlab chiqarish markazlari janubdan shimoliy rayonlarga cho'zilgan. Bu tadqiqotda Tozabog'yob madaniyatining (miloddan avvalgi XV-XI-asrlar) bronza metallurgiyasining rivojlanishidagi o'rni, xususan, qalay-bronza qotishmalariga tayanishi va qo'shni Andronovo madaniyat jamoalari bilan o'zaro aloqalari o'rganiladi. Ko'kcha 15A va Jonbos 21 kabi joylardan topilgan tigellar, qoliplar va metall buyumlarni o'z ichiga olgan arxeologik dalillar metallga ishlov berishning ilg'or usullarini ta'kidlaydi. Kimyoviy tahlillar shuni ko'rsatadiki, Tozabog'yob metallurgiyasi dastlab Ural-Volga rudalaridan foydalangan, keyin esa Qizilqum va Zarafshon manbalariga o'tgan, bu esa savdo tarmoqlari rivojlanib borayotganidan dalolat beradi. Tozabog'yob madaniyati shimoliy dasht ko'chmanchilari va janubiy agrar jamiyatlari o'rtasida vositachi bo'lib, metall buyumlar va xomashyo almashinuvini osonlashtirgan. Ushbu tadqiqot Markaziy Osiyo metallurgiyasining madaniy va iqtisodiy ahamiyatini ta'kidlab, mintaqaning Qozog'iston, Ural va undan tashqarida joylashgan bronza davrining kengroq almashinuv tizimlariga integratsiyalashuvini ta'kidlaydi.

**Kalit so'zlar:** *Bronza davri metallurgiyasi, Tozabog'yob madaniyati, Andronovo madaniyati, qalay-bronza qotishmalari, Qizilqum konlari, Zarafshon vohasi, O'rta Osiyo, savdo tarmoqlari, arxeologik kimyo, madaniy o'zaro aloqa.*

**Аннотация.** Расширение металлургической деятельности в Центральной Азии во 2-м тысячелетии до н. э. ознаменовало собой значительный сдвиг, при этом производственные центры распространились с юга на север. В этом исследовании изучается роль культуры Тозабогёб (XV–XI вв. до н. э.) в развитии металлургии бронзы, в частности, ее зависимость от сплавов олова и бронзы и взаимодействие с соседними общинами андроновской культуры. Археологические свидетельства, включая тигли, формы и металлические артефакты из таких мест, как Кокча 15А и Джонбос 21, подчеркивают передовые методы обработки металла. Химический анализ показывает, что металлургия Тозабогёб изначально использовала руды Урала и Волги, но позже перешла на источники Кызылкума и Зарафшана, что указывает на развивающиеся торговые сети. Культура Тозабогёб выступала в качестве посредника между северными степными кочевниками



и южными аграрными обществами, способствуя обмену металлическими изделиями и сырьем. Это исследование подчеркивает культурное и экономическое значение металлургии Центральной Азии, подчеркивая интеграцию региона в более широкие системы обмена бронзового века, охватывающие Казахстан, Урал и за его пределами.

**Ключевые слова:** металлургия бронзового века, культура Тозабогёб, андроновская культура, сплавы олова и бронзы, рудники Кызылкумов, оазис Зарафшан, Средняя Азия, торговые сети, археологическая химия, культурное взаимодействие.

**Abstract.** The expansion of metallurgical activities in Central Asia during the 2nd millennium BC marked a significant shift, with production centers extending from southern to northern regions. This study examines the role of the Tozabogyob culture (15<sup>th</sup> –11<sup>th</sup> centuries BC) in the development of bronze metallurgy, particularly its reliance on tin-bronze alloys and interactions with neighboring Andronovo culture communities. Archaeological evidence, including crucibles, molds, and metal artifacts from sites such as Kokcha 15A and Jonbos 21, highlights advanced metalworking techniques. Chemical analyses reveal that Tozabogyob metallurgy initially utilized Ural-Volga ores but later shifted to Kyzylkum and Zarafshan sources, indicating evolving trade networks. The Tozabogyob culture acted as a mediator between northern steppe nomads and southern agrarian societies, facilitating the exchange of metal goods and raw materials. This research underscores the cultural and economic significance of Central Asian metallurgy, emphasizing the region's integration into broader Bronze Age exchange systems spanning Kazakhstan, the Urals, and beyond.

**Keywords:** Bronze Age metallurgy, Tozabogyob culture, Andronovo culture, tin-bronze alloys, Kyzylkum mines, Zarafshan oasis, Central Asia, trade networks, archaeological chemistry, cultural interaction.

## Introduction

From the 2<sup>nd</sup> millennium BC, the distribution areas of metal products in Central Asia significantly expanded. Metallurgical centers and metallurgical industries, which used to operate in the south of the region, now also cover the northern regions.

During this period, the Southern Aral Bay region had a system of producers belonging to different ethnic-cultural groups, such as the Suvyorgon, Tozabogyob, and Amirabad cultures. In particular, in the early stages of the Tozabogyob culture (2<sup>nd</sup> half of the 2<sup>nd</sup> millennium BC), local metalsmiths began to produce decorative items, weapons, and household items. The discovery of a crucible (crucible) from the site of Kokcha 15 A, a mold of an ornament, and a mold of a spear blade from the site of Jonbos 21 from the first stage of this culture (15<sup>th</sup> -14<sup>th</sup> centuries BC) confirm the data [1-3]. In the Tozabogyob culture, the experiences of Andronovo culture communities were of great importance in the development of metallurgy.

## Literature Review

In the economic life of the communities of the Andronova culture, not only animal husbandry, but also mining, mining, smelting ore, and extracting metal raw materials

played an important role. They actively developed copper mines in the Southern Urals and Volga Rivers, Northern and Eastern Kazakhstan, and bronze metallurgy played an important role in the economy. During that period, the exchange of raw metal materials and the production of bronze products spread over vast areas from beyond the Urals to Central Asia. In the middle of the 2<sup>nd</sup> millennium, the production facilities related to the mining works of the Andronova and Tazobogyop culture communities - metallurgical centers and ore mines were located in the Nurota Mountains and Kyzylkum region [2]. During this period, tribes of Tozabogyob-type Andronova culture of the steppe regions, which are fundamentally different from the Zamonbobo culture and took its place, appear in the lower basins of the Zarafshan River. In the lower basins of Zarafshan, two cemeteries belonging to them and their seasonal settlements were found and studied at 26 points [1]. Among these monuments, the Gujayli cemetery is of particular importance.

V.D. Ruzanov's article "New information on the sources and chemical composition of the metal raw materials of the Gozhayli monument" is devoted to the analysis of the chemical composition of the metal objects recorded from the Gozhayli cemetery [9]. Based on the chemical indicators of the obtained objects, it was determined that there are genetic links and high percentages of similarity between the metal objects of the Gozhayli and Tozabogyob cultures. The percentage of tin bronze in their products is high.

V.D. Ruzanov's article on the topic "Tin-bronze industry of the steppe tribes of Central Asia between the rivers in the early metal age" also analyzed the recipe indicators (types of alloys, composition) of metalworking products in the steppe cultures of the Bronze Age between the two rivers [9]. According to the differences in the chemical parameters of the bronze objects of the steppe tribes, they are divided into three groups: 1) Arolboyi - Koyi Zarafshan; 2) Middle and upper Zarafshan; 3) Tashkent-Fergana.

The first group includes metalwork products of the Tazabogyab culture and Gujayli-type monuments. Among them, the group of tin bronze objects dominates (with a ratio of 81.5% and 68.4%). Here, the proportion of pure copper is significantly less (14.8% and 26.3%). Tin-lead alloys were rarely used (3.7% and 5.3%). During this period, other types of bronze alloys were hardly used.

It should be noted that the steppe regions of Kyzylkum and Zarafshan were considered a component of Tozabogyob culture. The ancient mines in Bukan-tao' and Altyn tao' regions in Kyzylkum were considered centers of supply of metal ore for Tozabogyob people. M.I. Itina's monograph "Southern Island steppe tribes (2<sup>nd</sup> millennium BC and the beginning of the 1st millennium BC)" contains some information about the sources of raw materials for the metallurgical industry of the inhabitants of the region. In particular, the author notes that the percentage of tin in the composition of bronze objects in the Kokcha 3 cemetery is large. The author doubts that the metallurgical products of the Tozabogyob culture were produced on the basis of raw materials brought from metallurgical centers along the Urals and the Volga [4]. The reason is that in the research, most of the metalworking products of the Srubno-Andronov tribes of this period were made of tin bronze, but it was known that there was no tin ore base in the Ural region [11].

It was from that period that the Andronova tribes of the South Urals received tin ore from the east and southeast, that is, from Central Asia [11]. Thus, the connections of the Andronovo tribes of Western Kazakhstan can be traced not only in the west (Srub tribes), but also in the Bronze Age steppe tribes of Central Asia in the south.

E. Chornykh stated that the close cultural and perhaps ethnic affinity between the Srub and Andronova ethnocultural communities and the Tozabogyob tribes are evidence of the existence of a single association that includes the metallurgical centers of Central Asia, Kazakhstan, Altai, and the Urals [11]. This proximity leads to the spread of similar forms in metalwork products, tools, and jewelry, while the inhabitants of each region retain their own ethnographic characteristics.

M.I. Itina's article "Excavations in the Kokcha 3 cemetery of Tozabogyob culture" suggests that there may be copper ore deposits in the Sultonuvais mountains near Tozabogyob, and there are ancient traces of copper smelting in Bukan-tau and Oltin-tau mountains [3]. Also, there is a high percentage of tin in bronze items in Kokcha area and information about tin-rich ore deposits in Kyzylkum based on research.

Based on the research led by Vinogradov A.V., he tentatively concludes that the source of raw materials for the metallurgy of the Southern Aral Bay region was processed in the Kyzylkum mountains [4]. Traces of slag associated with the reproduction of ore from the Eneolithic and Bronze Age were recorded from Beshbuloq and Mingbuloq sites in the Tomdi-tao', Bukan-tao' region of Kyzylkum. The analysis of archeological materials shows that the ore in the Beshbulok area was prepared not only for the surrounding metallurgical centers, but also as an export product for exchange in foreign trade [4].

According to the conclusions of M.A. Itina, the use of ancient ore deposits in Kyzylkum as a source of raw materials for the South Orolboi metallurgical sector in the Bronze Age can be clarified through special spectral-analytical and chemical research.

The chemical analysis conducted by Rozanov V.D. shows that the chemical analysis of bronze items in the Kokcha 15, 15 A, 16 areas of the Tozabogyob culture and the Kokcha-3 cemetery confirms that 70% of the items are metal items made from ore in the Bukan-Tomdi-Auminzatao area of Southern Kyzylqum [6]. Bronze products contained a high level of tin admixture. The geochemical composition of some objects belonging to a slightly earlier period (XV-XIV centuries BC) indicates that they were made from ore from the Volga, Kama rivers and Ural mines.

It should be noted that mil. avv. In the middle and late stages of the development of Tozabogyab culture in the XIV-XII, XI centuries, relations in the field of metallurgy were directed to the East and South, during this period, relations with the East were more active than in the North-Western regions [7].

Close contacts with the East are mainly established with areas rich in copper and tin (Kyzilkum and Zirabulok-Ziatdin mountains), in this regard, mil. avv. From the XIV-XII centuries, the use of ore sources of the Urals, the Volga and Kazakhstan in the production of metal objects of the Tozabogyab culture was sharply reduced, and it was replaced by the ore sources of the Kyzylkum region, the metal ore sources of this region played a key role in the development of the metallurgical industry in the Aralboi tribes.

It can be said that Khorezm used the South Kyzylkum mines as a source of raw materials in metallurgy from the Bronze Age to the Iron Age, and in some places even in the Middle Ages.

In his studies, Ruzanov V. shows three stages of the development of metallurgy in Central Asia. The first is present-day South Turkmenistan, which is strongly influenced by Iran, the second is the metal production center of Turan, and the third is the Chust-Burguluq metallurgical centers formed in the northeast of present-day Uzbekistan. The author does not deny the cultural influence of the nomadic northern peoples in the last two stages and recognizes the predominance of tin bronze in the region [8]. It shows that during the Bronze Age, tin-bronze deposits in Kyzylkum and Zarafshan oases were used as the main source of raw materials not only by the inhabitants of Tozabogyob and Amirabad cultures but also by almost all cultures of Central Asia.

### **Research Methodology**

The study employs a multidisciplinary approach, integrating archaeological, archeometallurgical, and comparative cultural analyses to investigate the development and exchange of metallurgical practices in Bronze Age Central Asia, with a focus on the Tozabogyob culture.

### **Analysis and Results**

As a result of the research in the areas of the Karnab and Mushiston mining areas, pottery fragments, stone hammers, and bone weapons characteristic of the nomadic Andronovo and Tozabogyob cultures were discovered [10].

According to the conclusions of the scientific research of many scientists, the share of tin bronze in metal objects (60-80%) in the monuments of the Zarafshan oasis steppe culture, Aralboyi Tozabogyob culture, Ettisuv, Kyrgyzstan, as well as Central and Eastern Kazakhstan, Alakul, Fedorov and Alekseev-Sargarin steppe cultures of the Bronze Age in Central and Eastern Kazakhstan [5].

Among the researchers, the opinion is that the inhabitants of the Tazabogyob culture acted as mediators in the developed metal trade in Central Asia, especially between the northern desert groups and the southern oasis cultures [10]. This trade was mainly carried out by exchanging agricultural or handicraft products from the southern oases for raw materials (copper and tin) or semi-finished raw materials and finished metal products from the Andronovo culture areas.

This unique center of culture of ancient metallurgists. av. In the 15<sup>th</sup> -13<sup>th</sup> centuries, it was active along the Southern Island and in the lower reaches of Zarafshan. In the 15<sup>th</sup> century, the inhabitants of the Tozabogyob culture mastered the field of metallurgy and metalworking, raw materials were exported to them from the mines belonging to the historical and cultural community of Andronova. Later, in the XIV-XIII centuries, the character of metallurgical furnaces changed; in particular, they operated on the basis of raw materials from Kyzylkum mines. During this period, the Tozabogyob metallurgical center was established as the western “outpost” of the Turan metallurgical region in the territories of present-day Uzbekistan, Tajikistan, and Southern Kyrgyzstan. It was active from the second half of the 2<sup>nd</sup> millennium to the beginning of the 1<sup>st</sup> millennium.



## Conclusion

The conclusions of these scientific studies testify that during the Bronze Age, the inhabitants of the Tozabogyob culture used tin-bronze mines in the Kyzylkum and Zarafshan oasis not only as consumers but also were one of the tribes that exported metal raw materials to foreign trade. This hypothesis can be justified by the spread of the steppe nomadic culture in the Bronze Age in the southern oases of Central Asia.

## References:

- [1] Askarov A. "Pamyatniki andronovskoy kultury v nizovyakh Zarafshana," Tashkent. *IMKU*. Vyp. 3, 1962, pp. 28-35.
- [2] Gryaznov M.P. "Pastoral tribes of Central Asia and the epoch of development and late bronze," *KSIA*. Vol. 122, M.: 1970, pp. 37-43.
- [3] Itina M.A. "Raskopki mogilnika tazabag'yabskoy culture Kokcha 3," *MXE*. Vol. 5, M.: 1961, pp. 3-96.
- [4] Itina M.A. "Istoriya stepnyx plemen Yuzhnogo Priaralya (II- nachalo I tysyacheletiya do n.e)," *TXAEE*. Tom X, M.: 1977, p. 239.
- [5] Ruzanov V.D. "Drevnie splayy Sredney Azii," *IMKU*. Tashkent: *Science*, Vol. 21, 1987, pp. 192-203.
- [6] Ruzanov V.D. "Rezultaty spektroanaliticheskikh issledovany metalla pamyatnikov Tazabagyabskoy kultury," *IMKU*. Samarkand, Vol. 27, 1996, pp. 200-204.
- [7] Ruzanov V.D. "K voprosu o svyazyakh priaralskikh plemen Uzbekstana v epokhu bronzy (po rezultatam issledovaniya metalla Tazabagyabskoy kultury)," *International symposium on the place of ancient Khorezm civilization in the system of world culture history and field seminar "Archaeology of the Ancient Tashkhirmon Oasis."* Nukus, 2000, pp. 31-32.
- [8] Ruzanov V.D. "Metalworking in Central Asia and the Bronze Age," Samarkand: *Institute of Archaeology, AN RUz*, 2013, p. 347.
- [9] Ruzanov V.D. "Novye dannye o khimicheskom sostave izdeliy i rudnykh istochnikakh metalla pamyatnikov Gudjayli," *History and archeology Turana*. № 1, 2017, pp. 38-44.
- [10] Ruzanov V.D. "Olovyanno-bronzovaya industria stepnyx plemen Sredneaziatskogo Mejdurechya v epokhu rannego metalla," *Istoriya i archeologiya Priaralya*. № 3, Nukus, 2022, pp. 33-37.
- [11] Chernykh E.N. "Drevneyshaya Metallurgy Urala and Povolzhya," *MIA* № 172, M.: *Nauka*, 1970, p. 185.
- [12] Shaidullaev Sh., Shaidullaev A. "Regarding the issue of the discovery of copper," *History of Uzbekistan magazine*. Issue 1, 2024, pp. 72-81.





UDC: 94, 7, 7.02, 7.04

## THE DISTINCTIVE FEATURES OF KAMOLIDDIN BEHZAD'S AESTHETIC VIEWS

**Masharipova Khusnibon Farxodovna**

*Teacher, Urgench State University named after  
Abu Rayhan Biruni*

[shixnazarmadiyorov@gmail.com](mailto:shixnazarmadiyorov@gmail.com)

**Annotatsiya.** Ushbu maqolada Kamoliddin Behzodning estetik qarashlari tadqiq etilib, uning original asarlari Temuriylar davri san'at an'alarining eng yuqori cho'qqisi va yetuklik namunasi sifatida tahlil qilinadi. Tadqiqot davomida Behzod kompozitsiyalaridagi uyg'unlik va mahorat, shuningdek, matn bilan badiiy uyg'unlikda ifodalangan elementlar uning nozik san'at mahoratini namoyon etishi ta'kidlanadi.

**Kalit so'zlar:** *Figuralar soni, boy bo'yoqlar, yashil va ko'k ranglar, sovuq ohanglar, ichki makon, iliq ranglar, ayniqsa yorqin to'q sariq, bezakli tasvirlar.*

**Аннотация.** В данной статье рассматриваются эстетические взгляды Камолитдина Бехзада и раскрывается, как его оригинальные произведения искусства представляют собой вершину и зрелость художественной традиции эпохи Тимуридов. В исследовании подчёркивается гармония и мастерство в его композициях, а также их органичное слияние с текстовыми элементами, что отражает его утончённое мастерство.

**Ключевые слова:** *количество фигур, насыщенные пигменты, зелёный и синий, холодные оттенки, внутреннее пространство, тёплые цвета, особенно яркий насыщенный оранжевый, декоративные изображения.*

**Abstract.** This article explores the aesthetic ideas of Kamoliddin Behzad and reveals how his original artworks represent the culmination and maturity of the Timurid artistic tradition. The study emphasizes the harmony and craftsmanship in his compositions and their seamless integration with textual elements, which reflect his refined mastery.

**Keywords:** *Number of figures, rich pigments, green and blue, cool tones, interior space, warm colors, especially bright deep orange, decorative imagery.*

### Introduction

The great miniature artist, an outstanding figure of the Eastern Renaissance, and recognized in the West as the "Raphael of the East", Kamoliddin Behzod was born in 1455 in Herat into an artisan family. From the 1480s onwards, artworks bearing Behzod's signature began to appear, although autographs are rare, and most are believed to have been inscribed by later calligraphers. Behzod did not sign all of his works, and many counterfeit pieces exist that falsely attribute authorship to him. Kamoliddin Behzod experimented with various techniques to advance artistic technology and, in addition to realistic pieces, produced highly decorative paintings. In the illustrations of Nizami's "Khamsa" manuscript, flat color patterns add a sense of dynamism to the canvas and create a sense of unity. Although Behzod produced

many portraits, portraiture was not initially a dominant field in Persian painting. His portraits are believed to have been influenced by European artists such as Gentile Bellini, who was invited to Istanbul by the Ottoman Emperor Mehmed II in the late 15<sup>th</sup> century.

### **Literature review**

The figures in these portraits are drawn with delicate, realistic lines, and their garments are richly adorned-emphasizing the decorative quality typical of Persian painting [1].

Behzod was highly esteemed by both contemporaries and successors. According to legend, Sultan Husayn Bayqara, once in a state of depression, lightened up after viewing Behzod's caricatures of court officials. On the other hand, Babur, founder of the Mughal Empire, criticized the disproportionate facial features of the beardless figures in Behzod's portraits. Through his works and his followers, Kamoliddin Behzod significantly influenced the development of miniature painting in the Shaybanid, Ottoman, and Safavid dynasties. Young artists who worked with Behzod in Tabriz introduced new elements into the aging master's style, further advancing the miniature tradition. One of his students from the Herat period, Shaykhzada, was invited to Bukhara by Abdulaziz of the Shaybanid dynasty and continued the portrait style of his master. The Bukhara school of painting, inheriting Behzod's traditions, produced works with more Persian elements compared to the Samarkand school, which was more strongly influenced by Chinese ink painting [2].

None of the artworks attributed to Behzod contain his definitive signature; thus, the authenticity and identification of his actual works are determined by stylistic analysis. According to experts, among the many works attributed to Behzod, only thirty-two paintings are considered authentic, representing only about ten years of his long artistic career. In the 10<sup>th</sup> century Hijri, collectors eagerly sought to include Behzod's paintings in their collections. According to a portrait of Behzod held at the Evkaf Library in Istanbul, Laurence Binyon and others described his character as humble and modest yet sharp and thoughtful. His appointment as director of the royal library supports this characterization. Shah Ismail likely considered him a capable administrator. According to Khwandamir, Behzod was endowed with pleasant and friendly qualities. In addition to his relationships with Alisher (Navoi), he was supported by four monarchs, and two Safavid rulers gave him special attention [3].

Behzod's prestige stems primarily from the idealism reflected in his works, as well as from his personal qualities and continuous collaboration with intellectual leaders and great rulers of his time. However, his personality did not quite match his fame- as noted by his historian friend Khwandamir- and his associations with Alisher and Jami have been recorded. This led to an exaggeration of his fame. On the other hand, fair-minded figures such as Babur and Haydar Mirza confirmed his high status among contemporaries. Nevertheless, it remains difficult to definitively determine the full extent of his originality or clear superiority over all other painters.

### **Research Methodology**

The evaluation of Behzod's significance as a painter reveals a wide range of

opinions. In the book “Khondamir al-Akhbar”, written in 905 AH and describing historical events up to 875 AH, Behzod’s situation in Herat is noted. According to Khondamir, Behzod was first supported by Mir Alisher and later by Sultan Husayn, who praised his artistic activity. However, Khondamir does not emphasize Behzod’s superiority over his contemporaries. In fact, his list of artists begins with Mirek Naqqash, who was likely the leading painter of that time, and his highest praise is directed toward Behzod’s contemporary, Qasim Ali. Furthermore, as indicated by the words of Mirzo Haydar Dughlat and Babur, Behzod was one of the few skilled painters active in the circles of Alisher and Sultan Husayn in Herat. They preferred Shah Muzaffar or Qasim Ali over Behzod’s works. Behzod’s recognition as an outstanding painter first emerged during the Safavid era. Writers typically praised him with admirable but often generic qualities, comparing his skill to Mani, the greatest painter in Persian literature. In the revised version of the historical work “Habib al-Siyar”, completed in 930 AH, Khondamir glorifies Behzod, likening him to Mani and claiming that his talent surpassed all other artists. Additionally, in the above-mentioned decree attributed to Shah Ismail in 928 AH, Behzod is compared to Mani and praised as a “model painter.”

### **Analysis and Results**

Behzod’s innovations reached their peak in the illustrations of Sa’di’s *Bustan* and Nizami’s *Khamsa*. These works were created in the intellectual atmosphere of Sultan Husayn Bayqara’s court and were influenced by the mystical worldview of scholars like Jami and Navoi. Behzod’s paintings were displayed for the library of Sultan Husayn Bayqara, and an inscription dated 893 AH highlights the essence of his achievements. The *Bustan* manuscript includes two title pages and four illustrations. Behzod’s signatures in these paintings are either subtly placed in architectural elements or hidden within objects. Two of these illustrations are dated 894 AH. All of the paintings contain text panels that are intricately linked with the page borders, showing that Behzod collaborated closely with the calligrapher Sultan Ali Katab. The illustrations are distinguished by their carefully balanced compositions, which define spatial clarity uncommon in Eastern visual art. These figures, although idealized, often express a much more refined sense of posture and character than typically seen in Persian manuscripts. Moreover, the works demonstrate meticulous design and execution control characteristic of the Herat school. Similar stylistic traits are clearly visible in other paintings attributed to Behzod in Herat. Ivan Stchoukine documented various experts’ views on these traits. Manuscripts commonly associated with Behzod include the 872 AH copy of Yazdi’s *Zafarnama* (housed in the Johns Hopkins University Library), the 888 AH copy of *Mantiq al-Tayr* by Attar (Metropolitan Museum of Art, New York), and Alisher Navoi’s *Khamsa* of 890 AH (split between the Bodleian Library in Oxford and the John Rylands Library in Manchester), as well as two copies of Nizami’s *Khamsa* (British Library), where illustrations were added to a text copied in 846 AH and published in 900 AH.

Although ancient sources do not provide extensive details about Behzod as an artist, they praise him as the greatest of his time. Khondamir highlights the refinement, intellectual depth, and realistic power in Behzod’s paintings. Haydar Mirzo compares

him with his teacher Mirek and believes that while Behzod may not surpass his master in artistic maturity, his brushwork and compositional arrangement are superior—though not in elegance. Qazi Ahmad emphasizes proportionality in Behzod's works, noting his skill with charcoal and his excellence in depicting birds. Babur praises his art for its "extreme delicacy and fineness", especially admiring the ornate quality of bearded figures while noting that the beardless ones are less successful and that he sometimes exaggerated the size of the foreheads. Babur's descendants in the Mughal dynasty were also admirers of Behzod and made efforts to collect his works for their libraries, with multiple mentions of their purchasing his paintings. However, some of Behzod's works had been collected earlier, as a few were found in the collection of the Safavid prince Sultan Ibrahim Mirza (d. 984 AH).

Jahangir Shah was among the first to acknowledge Behzod's talent for designing battle scenes, a point noted elsewhere. Due to public admiration, Behzod's name became firmly established and celebrated. Khondamir believed that he deserved to be ranked alongside Mani, the legendary creator of ancient masterpieces. However, Qazi Ahmad, typically more reserved in Persian exaggeration, states: "Had Mani met him, he would have followed him." Nevertheless, Mustafa Ali asserts that Behzod's success was partly due to the influence and credibility of his supporters. These intrigues and alleged envy may have contributed to his name being included among Iranian artists and calligraphers in the anthology of Safavid prince Sam Mirza.

Modern research is increasingly focused on identifying the originality and authenticity of Behzod's works. This became particularly evident after the 1350 AH exhibition of Iranian art. In London, where many of Behzod's attributed works were gathered, some progress was made. However, it is still difficult to distinguish him from others based solely on his artistic style, as many works remain ambiguously attributed to his predecessors and contemporaries. Behzod's fame has led to some works being falsely or mistakenly attributed to him over the centuries- sometimes for material gain, or to enhance a collection with a leaf allegedly by a renowned artist, or through later additions across generations. This complicates the issue further, as works associated with Behzod may be fully signed, partially copied, or even completed posthumously or forged, leading to diverse approaches in scholarly analysis.

The true scholarly foundation for understanding Behzod's art lies in the *Bustan* manuscript illustrations, completed in Rajab 893 AH in Herat. The version housed in the Egyptian National Library in Cairo was penned by the calligrapher Sultan Ali and illuminated by the artisan Yari Mazhab for Sultan Husayn Bayqara. The edition includes two title page illustrations- whose signatures were removed- and four single-page illustrations dated 893 and 894 AH. In the last two illustrations, Behzod's name appears so frequently in the architectural details that their later addition seems unlikely. The other two signatures are so faint that they appear to be original. The uniform style and features of these paintings have led to their general acceptance as Behzod's authentic works. These paintings reflect the peak and maturity of the Timurid style. Their harmonious and skillful compositions are strongly integrated with the accompanying text sections. According to the aesthetics



and understanding of the time, the limited number of figures on each page is well distributed within the pictorial space. The pigment variety is rich, with an exceptional sense of color. These works show Behzad's preference for cool tones such as green and blue, especially for interior scenes, consistently balanced with warm hues, particularly vibrant orange. Every element of color complements the decorative imagery, executed with great professionalism. The blossoming tree branches, intricate tile designs, and carpet patterns demonstrate the artist's refined aesthetic sense and meticulous execution. However, it is realism that distinguishes these works from earlier paintings. What is particularly evident in this iconographic style is its non-judicial nature- they are not dedicated to depicting chivalric behavior or the romantic exploits of kings. Rather, these works capture everyday events- such as a drunken prince's conduct, performing ablution in a mosque, or observing a foal and slaves in the stable- highlighting his interest in the activities of lower social classes, like porters.

### Conclusion

Kamoliddin Behzad's artistic legacy represents the pinnacle of Timurid miniature painting, characterized by harmonious compositions, masterful use of color, and a refined balance between decorative richness and realism. His works, particularly in manuscripts like *Bustan* and *Khamsa*, demonstrate a sophisticated integration of text and imagery, with a distinct preference for cool tones and vibrant warm accents. Despite challenges in authenticating his oeuvre, Behzad's influence on Persian, Mughal, and Ottoman art remains undeniable. His depictions of everyday life, rather than solely royal or heroic themes, set him apart as a visionary artist of the Eastern Renaissance. While debates persist regarding his originality and superiority over his contemporaries, his contributions to miniature painting endure as a testament to his skill and enduring legacy.

### References:

- [1] Roxburgh, David J., "Kamal al-Din Bihzad and Authorship in Persianate Painting," *Muqarnas*, Vol. XVII, 2000, pp. 119–146.
- [2] Akimushkin, O. F. "The Legend of the Artist Behzad and the Calligrapher Mahmud Nishapuri." *Peoples of Asia and Africa*, 1963, No. 6, pp. 140–148.
- [3] Ashrafi, M. M. "Stages and Directions in the Study of Behzad's Work." In: *Kamoliddin Behzad and Current Issues of Central Asian Culture: Collection of Articles*, Dushanbe, 2001, pp. 160–163. "Behzad and the Problem of Tradition in the Medieval Miniature of Iran and Central Asia." In: *III All-Union Conference "Art and Archaeology of Iran and Its Connection with the Art of the Peoples of the USSR from Ancient Times": Abstracts of Reports*, Moscow, 1979, pp. 18–19.
- [4] International Scientific Conference on the Theme "Kamoliddin Behzad's Art in the View of World Scholars." Tashkent: Zamon Poligraf Publishing House, 2022, p. 141.
- [5] Aini, L. "Timurid Miniature and Its Specifics." *Peoples of Asia and Africa*, 1971, No. 3, pp. 141–143.
- [6] Adamova, A. T. "On the Problem of Authorship in Persian Miniature Painting of the 17th–19th Centuries." In: *Artistic Monuments and Cultural Issues of the East: Collection of Articles*, Leningrad, 1985, pp. 202–208.





UDC: 308, 796.01

## SOCIAL-PHILOSOPHICAL FOUNDATIONS OF MORAL CULTURE

**Karayev Nizam Abduraimovich**

*Advanced training Institute of the  
Ministry of Internal Affairs of the  
Republic of Uzbekistan  
Karayev@inbox.ru*

**Annotatsiya.** Mazkur maqolada axloqiy madaniyatning ijtimoiy-falsafiy asoslari masalasi yoritilgan. Axloqiy madaniya insonda uning xulqi orqali namoyon bo'ladi. Xulq esa kishilarning ongi va irodasi bilan belgilanadigan axloqiy hatti-harakatlarning yig'indisidir. Axloqiy madaniyat qoidalari bu insoniyatning asrlar osha o'z tajribasi orqali erishgan natijalaridir.

**Kalit so'zlar:** *axloq, xulq, me'yor, hatti-harakat, qoida, ong, tafakkur.*

**Аннотация.** В данной статье рассматривается вопрос социально-философских оснований нравственной культуры. Нравственная культура проявляется в человеке через его поведение. Поведение – это совокупность нравственных действий, определяемых разумом и волей людей. Правила нравственной культуры являются результатом многовекового человеческого опыта.

**Ключевые слова:** *мораль, поведение, норма, поведение, правило, сознание, мышление.*

**Abstract.** This article discusses the socio-philosophical foundations of moral culture. Moral culture is manifested in a person through his behavior. Behavior is the sum of moral actions determined by the consciousness and will of people. The rules of moral culture are the results achieved by humanity through its own experience over the centuries.

**Keywords:** *morality, behavior, norm, behavior, rule, consciousness, thinking.*

### Introduction

Morality regulates the character, behavior of people, and their mutual relations in social and personal life. Moral norms are the requirements imposed on the character of an individual by society or a specific group. These norms include the attitude of an individual to society - the Motherland, state, nation, group, as well as the behavior of an individual in life, in relations with certain people, in his profession, specialty, and even in his relationship with himself.

Moral culture is related to the study of the origin and essence of human culture, its moral relations in society, and is a set of positive actions that can serve as an example for society, time, and humanity.

### Literature Review

Morality - Russian - moral, derived from the Latin words "mores," "moralis," meaning behavior, custom. Morality is a specific form of social consciousness, a set of principles and norms of behavior and behavior of people in their social and personal

lives. The word and concept of morality are also Arabic and are the plural of the word “morality” [1].

The word “morals” is derived from Arabic and is the plural form of the word “khulq”. The term “morals” as a general concept refers to a wide range of human behaviors and actions [2]. If we analyze morality as a general concept from the perspective of human life, its smallest part is etiquette, its largest part is behavior, and its most comprehensive part is morality. Manners include beautiful actions based on national traditions that create a pleasant impression of a person and are important in the life of a community, society, and humanity. Khulq is a set of pleasant human actions that are significant at the family, community, and neighborhood level and have a significant impact on the life of society and humanity.

Moral culture was considered an integral part of philosophy in ancient times, along with physics and metaphysics, and later (after Aristotle) was formed as a separate philosophical direction. Moral culture organizes the development of moral thinking and serves to lead a person to truth through virtue in practice.

The rules of moral culture are the norms that express the wisdom gained by humanity through its own experience over the centuries in the form of proverbs, sayings, and proverbs, which teach people moral laws and rules and explain to them the essence of morality [3]. After all, every action and intention of a person belongs to his moral culture, embodying the qualities of goodness and refinement along with certain positive activities. As is known, since human society is constantly developing, its views on moral culture are also constantly changing, developing, and progressing. The concepts of good and evil also change and develop.

Moral culture is manifested in a person through his behavior. Behavior is the sum of moral actions determined by the consciousness and will of people. The behavior of people plays a major role in the formation of moral cultures in society and in creating a moral environment in society. An element of character characteristic of behavior is moral behavior. Behavior is an activity that demonstrates the positive or negative qualities of a person. In other words, behavior is a consciously directed and completed action or activity of a person. Behavior does not consist only of direct action. They can also be expressed in inaction - silence, passivity, indifference- or in relationships in the form of gestures, postures, and tones.

### **Analysis and Results**

In behavior, in a person’s actions, his inner spiritual world, thoughts, feelings, aspirations, and decency are reflected. Both positive and negative manifestations of moral requirements existing in society are manifested in behavior. Morality is a set of actions that, as a unity of consciousness and activity, demonstrate goodness and evil, justice or injustice, conscientiousness or dishonesty [4]. Therefore, we can express our opinions based on behavior and actions. It is known that a certain action itself can be assessed as evil. Of course, in this case, both assessments will not be correct. In order for a moral assessment not to be falsely subjective, it is necessary to rely on the objective criterion of moral relations, the universal character of which is only possible in a particular society.

In the moral assessment of a particular activity, a moral motive, which expresses a person's subjective attitude to his actions, plays an important role. Motives of behavior can be positive or negative. We condemn any actions that contain egoistic motives, even if they give objectively positive results.

Actions are morally evaluated when they affect the interests of another person, society, or group. People's actions are evaluated and valued as good or bad not in themselves but as part of social life. Although it may seem like the right thing to do on the surface, actions that are done for the sake of one's own fame, reputation, or benefit cannot be considered moral. The level of morality of actions is determined by their awareness, sincerity, impartiality, voluntariness, and free choice.

A person cannot live in a certain society and be free from that society. This directly affects the moral image of people and imposes certain educational and spiritual requirements on their behavior. When evaluating people, regardless of their age, profession, specialty, or level, emphasis is placed on whether they are moral or immoral, educated or uneducated, intelligent or uneducated. This expresses the moral image, behavior, and good or bad actions of people.

Look, even if each person is a world, even if he is a unique, unique miracle, he cannot live alone, be neither happy nor unhappy. Therefore, a person, by his essence, by his nature, is closely connected with society, lives as a community, makes a living, takes an example from society, and makes his contribution to society. Making a positive or negative contribution to society depends on his intelligence, conscience and will, his faith and beliefs and lifestyle, his spiritual upbringing and moral culture. After all, as the enlightener Abdulla Avloni noted, "Education is for us a matter of life or death, salvation or destruction, happiness or disaster" [5]. These words of the great enlightener were as important and relevant for our nation as they were at the beginning of our century, and they have not lost their relevance today. Education is a product of consciousness, but at the same time, it is a factor that determines the level of consciousness and its development. Therefore, consciousness cannot be changed without changing the education system. And without changing consciousness and thinking, the highest goal we are pursuing - a free and prosperous society - cannot be established" [6].

## **Conclusion**

It is an old truth that man lives with man in society. But each person is created as a world in himself, and no one is exactly like anyone else. That is why human desires and needs, dreams and hopes, ideas about good and evil, happiness and love are also different. Such diversity creates the basis for people to follow different paths to realize their intentions and desires. Where there is good, there is evil, which leads to the formation of various immoralities among people and the commission of illegal actions. Today, it is the responsibility of the internal affairs bodies, qualified by law, to control these actions.

Today, in society, it would not be wrong to say that the employees of the internal affairs bodies, who are not only respected by ordinary citizens, but also real guardians of the law and symbols of justice, have a high moral culture, and as high moral people who have dedicated their lives to their nation and homeland and the interests of



humanity, they serve as an example for the society in which they live, and serve the further development of that society. If, in society, the opposite is true, that is, if, while becoming a defender of the law, they themselves violate the law, if they consider white as black and black as white for the sake of personal gain, such an employee has committed immorality. As a result, ordinary citizens have a false perception that the entire society is unjust because of one immoral person, and the constant strengthening of this perception ultimately leads to the decline of that society. Most importantly, it is also a fact that almost all studies that study the period have documented with solid facts that the peak of immorality in human history has caused harm to a nation or country (as in the case of the actions of totalitarian regime rulers) and led to tragedies on a global scale.

#### References:

- [1] Abdulla Sher. "Axloqshunoslik," Oliy ta'lim muassasalarining bakalavriat ta'lim yo'nalishlari uchun darslik. T.: *O'zbekiston faylasuflari milliy jamiyati nashriyoti*, 2010, p. 328.
- [2] "O'zbekiston Milliy Ensiklopediyasi," Birinchi jild. Toshkent, 2000.
- [3] Muhammadjanova L., Abdulla Sher, Shadimetova G. "Axloq falsafasi," Darslik. Toshkent, 2023, p. 208.
- [4] Семёнов В. "О перспективах человека в XXI столетии," Вопросы философии. Москва, №9, 2005, p. 27.
- [5] Avloniy A. "Turkiy guliston yohud axloq," T., 1992.
- [6] "Barkamol avlod orzusi," Toshkent: Shark, 1999, p. 3.

UDC: 308, 796.01, 316

### THE ESSENCE OF THE CONCEPT OF VALUES A CONTENT

**Maksumov Khamza Valikhonovich**

*Scientific Candidate, Institute of the Ministry  
of Internal Affairs, Republic of Uzbekistan*

[KHMaksumov@mail.ru](mailto:KHMaksumov@mail.ru)

**Annotatsiya.** Mazkur maqolada qadriyat tushunchasining mohiyati a mazmuni yoritilgan. Qadriyatlarning mohiyati, mazmuni bilan bog'liq muammolar tahlili uzoq tadrijiy rivojlanish tarixiga ega. Vatanimiz sivilizatsiyasida qadriyatlar uyg'unligi o'ziga xos bir emas ikki renessansning vujudga kelishiga zamin yaratgan. Bugungi kunda barcha ijtimoiy-iqtisodiy va siyosiy islohotlarga hamohang ravishda oilaviy qadriyatlarga ham alohida e'tibor qaratilmoqda.

**Kalit so'zlar:** qadriyat, axloq, me'yor, qoida, oilaviy qadriyatlar, qadriyatlar falsafasi.

**Аннотация.** В данной статье описывается суть и содержание понятия ценности. Анализ проблем, связанных с сущностью и содержанием ценностей, имеет длительную историю постепенного развития. Гармония ценностей в цивилизации нашей страны создала почву не для одного, а для

двух ренессансов. Сегодня в рамках всех социально-экономических и политических реформ особое внимание уделяется семейным ценностям.

**Ключевые слова:** *ценность, мораль, норма, правило, семейные ценности, философия ценностей.*

**Abstract.** This article discusses the essence of the concept of values a content. The analysis of problems related to the essence and content of values has a long history of gradual development. The harmony of values in the civilization of our homeland has created the basis for the emergence of not one, but two unique renaissances. Today, in parallel with all socio-economic and political reforms, special attention is paid to family values.

**Keywords:** *value, morality, norm, rule, family values, philosophy of values.*

## Introduction

As time passes and society develops, the problems in this regard increase, and the importance of solving them increases. The analysis of problems related to the essence and content of values has a long history of gradual development. Since ancient times, people have evaluated the world around them, things, events and phenomena in it, and relationships between people, and have thought about their value.

The philosophy of values is also reflected in religious worldviews and their oldest forms, expressing certain divine values mixed with national values. Examples of Uzbek folk oral art, such as Spetamen, Alpomish, To'maris and Shirok, depict patriotism, self-sacrifice for the freedom of the people and the country, and explain the value of the universe, its infinity, the relationship between the universe and humanity, the meaning, content and purpose of human life, as well as values such as courage, wisdom, modesty, goodness, loyalty and patriotism.

## Literature Review

Since values are the basis of a number of worldviews and constitute a central part of those worldviews, many thinkers have put forward views and conclusions on the philosophical analysis of values. Analyses on the philosophy of values were also recorded by ancient Eastern and Central Asian thinkers. In particular, views on the philosophy of values are presented in the scientific heritage of thinkers and scientists such as Al-Khwarizmi, Al-Farabi, Al-Biruni, Ibn Sina, Najmiddin Kubro, Al-Bukhari, At-Termizi, Ahmad Yassavi, Mirzo Ulug'bek, Abdurakhmon Jomi, Alisher Navoi, Boborahim Mashrab, Mirzo Bedil, Makhtumkuli, Mahmudkhodja Behbudi, Abdulla Avloni. After all, it is true that the philosophical analysis of values goes back to ancient proverbs, legends, myths, stories, epics, that is, examples of folk oral art created in our land, and since this folk oral art pays more attention to universal and universal values, their essence and content are also widely interpreted [1].

As the historical forms of religions have improved, their value systems have also shown new facets. The ancient book of our ancestors, the Avesta, is the brightest example of our religious and philosophical heritage, a work that illuminates the universal values of our ancient peoples. Since the Avesta is the sacred book of Zoroastrianism, the value system of this religion is reflected in it. At the same time, the book gives great importance to universal values, their importance for human



spirituality and practical activity. The work demonstrates such qualities as goodness, perfection, liberalism, and humanity. According to the teachings of Zoroastrianism, people should follow the forces of goodness and light, distinguish good from evil and justice from injustice, and have good thoughts, good words, and good deeds throughout their lives. The value of man in this process, his indifference to the struggle for the victory of good, was expressed in his way of life, spiritual image, and social activities, creating the basis for the development of his unique natural, scientific, and moral values in the pre-Islamic period.

### **Research Methodology**

This study employs a comprehensive qualitative research methodology to examine the historical development and contemporary manifestations of value systems in Uzbek culture. The research design incorporates multiple methodological approaches to ensure a thorough investigation of the philosophical foundations of values.

### **Analysis and Results**

The 8<sup>th</sup> - 12<sup>th</sup> centuries were of great importance in the development of views on values in Central Asia. During this period, the divine values of Islam had a tremendous impact on the history and culture of our people.

The harmony of values in the civilization of our homeland created the basis for the emergence of not one but two unique renaissances. As a result, thinkers such as Khorezm, Al-Farabi, Al-Biruni, Ibn Sina, Ulugbek, outstanding scholars of theology such as Al-Bukhari, At-Tirmidhi, Kubro, Ahmad Yassavi, Naqshband, Lutfi, Navoi. The influence of not only Islam, but also the culture and values of our civilization was incomparable in the development of scholars such as Babur, Bedil, and Mashrab. In short, social relations related to spiritual values of that time developed inextricably linked with the lifestyle, material needs, interests, demands, and goals of people [2].

The same can be said about the views popular among the peoples of the East. As for the works mentioned above, there are only a handful of books in the world that can compare to them and explain general systems of spiritual and moral values.

One of the most prominent figures of Sufism, Ahmad Yasawi (1105-1166), described the conditions of religious, spiritual, and moral values that were appropriate for that time from the perspective of Islam. For example, in Ahmad Yasawi's work "Divani Hikmat," he described the main forms of spiritual values - purity, modesty, endurance and patience-contentment, endurance, indifference, humility. After all, it was the Yasawi order that was widespread among the peoples of the East, had a great influence on the cultural heritage, and the spiritual values of this order later gave rise to the ideas of achieving freedom from the Mongol invasion. It would also be no mistake to say that this teaching was one of the spiritual foundations connecting the values of the period before the Mongol invasion with the era of the Timurids [3].

The importance of the Naqshbandi order and the ideas and views it put forward in the philosophy of values is incomparable. When the Naqshbandi order spread widely in the East, it was deeply respected by such influential thinkers of the East as Abdurahman Jami and Alisher Navoi. In this, the main qualities of a perfect person, such as "hands in work, heart in creation" in the idea of the order, honesty, and humility, were promoted [4].

In the late 19<sup>th</sup> and early 20<sup>th</sup> centuries, when the unique ideas of Jadid philosophy began to emerge in our country, a unique Jadid-specific direction of Eastern values began to emerge.

In particular, Abdullah Avloni's work "Turkish Rose or Morality" describes a unique system of spiritual values, and in the work, values such as enthusiasm, courage, contentment, knowledge, patience, discipline, self, conscience, love of the homeland, chastity, modesty, understanding, speech, economy, obedience, loyalty, justice, love, and forgiveness are analyzed under the name of "good manners." The values mentioned in this work are an indication of how wide the scope of spiritual concepts was in our country at that time and how rich our language was [5]. Through the Eastern definition and description of universal human values by scholars of the Middle East, we witness the formation of unique Eastern value criteria in the philosophy of values.

From the analysis of various cases of manifestation of the philosophy of values, taking into account the sequence of events and phenomena, the realities of time and space, and the continuous repetition of such cases, it is possible to come to the following important conclusion, which expresses the connection of value systems with social reality and development. This conclusion, expressing the main content of the law of the connection of the value system with social development, has acquired not only theoretical but also practical significance in connection with the changes in the present time and has created the basis for the application of these rules in practice. More precisely, the value of independence was formed. The manifestation of the complex changes taking place in Uzbekistan in the field of values had a practical impact on the aspects of changes in the social life of the republic related to the value factor and criterion, leading to the formation of a new value system based on independence. As a result, it was possible to correctly interpret the sense of value in people and incorporate it into the components of new reforms in Uzbekistan. Under the slogan that man is the highest value of society, the representative of the generation that continues the human race, the inviolability of the right to life of every person, and everything is for man, enhancing human value has become the main criterion for development.

In recent years, historical reforms on the path to building a New Uzbekistan, first of all, efforts to comprehensively protect human dignity and the interests of the people, are aimed at further strengthening people's confidence in the future and comprehensively satisfying our people. Along with all areas, special attention is paid to radically improving the activities of law enforcement agencies capable of reliably protecting the peaceful and quiet life of our people and our national interests. In this regard, the issue of maintaining public order and ensuring security is of priority, and significant results have been achieved in ensuring the inviolability of our Motherland and citizens and creating the legal foundations of peace and tranquility.

In line with all socio-economic and political reforms, special attention is paid to family values, emphasizing that the family is not only a factor in the continuation of the human race but also a center of social education that educates members of society, especially the growing younger generation, in the spirit of patriotism.

## Conclusion



The main goal of the reforms being implemented today—Systematic work is being carried out to ensure public peace and tranquility, study the social situation in neighborhoods, identify problematic and difficult families in a timely manner and provide them with comprehensive support. The main goal of this is to prevent possible violations and crimes by ensuring the well-being of the population. The peace, well-being and sustainable development of the family are considered one of the important factors determining the peace of the country and the standard of living of the population. Today, as a result of targeted work carried out in our country through door-to-door visits in administrative regions, comprehensive studies of neighborhoods are being carried out, especially identifying problematic and troubled, socially disadvantaged families and women in difficult social situations, and transforming them into active and exemplary members of social life. A number of targeted programs and measures are also being implemented, aimed at supporting the population socially, materially, and spiritually, as well as early detection of crime and timely elimination of the factors that cause it. In particular, the creation of family values creates the basis for studying all neighborhoods and families in our country and their existing problems and implementing targeted work to solve them.

#### Reference:

- [1] “From the history of superstition of Central Asian peoples,” T.: *Science*, 1990, p. 104.
- [2] “From the history of socio-philosophical thoughts in Uzbekistan,” T.: *Uzbekistan*, 1995, p. 6.
- [3] Nazarov K. “Philosophy of Values (Axiology),” Tashkent: *Publishing House of the National Society of Philosophers*, 2004, p. 85.
- [4] Rakhmonov S. “Great geniuses of two orders (on the example of Mawlana Jalaluddin Rumi and Khoja Bahauddin Naqshband),” Samarkand: *Samdech Tehnologiya Publishing House*, 2021, p. 148.
- [5] Avloni A. “Turkish Gulistan or Ethics,” T., 1992.

UDC: 8, 80, 81, 821.111

**THE COMPARATIVE STUDY OF THE CONCEPT OF “FRIENDSHIP”  
IN KOREAN AND UZBEK PROVERBS**

**Jamila Ermetova**

*Associate Professor (PhD), Korean Studies  
and Language Education project  
coordinator, Urgench State University  
named after Abu Rayhan Biruni  
[jamilaismailovnae@gmail.com](mailto:jamilaismailovnae@gmail.com)*

**Charos Matchanova Shakirjon Kizi**

*Bachelor Degree Student, Philology and  
Language Teaching: Korean language,  
Urgench State University named after Abu  
Rayhan Biruni  
[charosmatchanova02@gmail.com](mailto:charosmatchanova02@gmail.com)*

**Annotatsiya.** Maqollar rostgo‘ylik, mehnatsevarlik, mardlik, matonat kabi fazilatlarni singdirish orqali inson ongini yuksaltirishda, ijobiy insoniy fazilatlarni targ‘ib etishda muhim ahamiyat kasb etishi keng e‘tirof etilgan. Ushbu maqolamizning maqsadi do‘stlik haqidagi koreys, o‘zbek va ingliz xalq maqollarini lingvistik jihatdan tahlil qilish; hamda ularning madaniy yaqinlik va tafovutlarini yoritishga qaratilgan.

**Kalit so‘zlar:** xalq maqollari, do‘stlik, qadriyat, hamrohlik, tamoyillar va xalqlarning tarixiy taraqqiyoti.

**추상적인.** 속담은 진실성, 정직성, 성실성, 용기, 용기, 인내와 같은 가치를 심어주며 인간 의식 함양에 중추적인 역할을 한다는 것이 인정되고 있습니다. 이러한 가치는 속담을 통해 증진되며, 긍정적인 인간 덕목을 함양합니다. 이 글의 목적은 두 언어로 된 우정에 관한 속담을 분석하고 그 의미, 언어, 문화적 유사점과 차이점을 탐구하는 것입니다.

**핵심 단어:** 민간 속담, 우정, 가치관, 국가의 역사.

**Abstract.** It is acknowledged that proverbs play a pivotal role in the cultivation of human consciousness, instilling values such as truthfulness, honesty, diligence, courage, bravery, and perseverance. These values are promoted through proverbs, fostering positive human virtues. The purpose of this article is to analyze proverbs about friendship in two languages, exploring their semantic, linguistic and cultural similarities and differences.

**Keywords:** folk proverbs, friendship, values, history of nations.

## Introduction

It is evident that proverbs have existed since ancient times in every nation's language, emerging from each ethnic group's mentality, worldview, and customs. However, observations suggest that the concept of proverbs is present in every culture and that they are replete with the experiences of past generations. Beyond their capacity to reflect the customs and national concepts of a people, proverbs also encompass historical places, prominent figures, and famous personalities of the nation. Moreover, proverbs characteristically convey meanings that advocate for goodness and righteousness. Thematic diversity is a hallmark of proverbs, with friendship being a recurring subject. Proverbs concerning friendship impart lessons, provide instruction, and advocate for moral upbringing. Friendship is recognized as one of the oldest and most significant social relationships in human history, and it reflects the unique cultural characteristics and lifestyles of each nation. As previously mentioned, proverbs often embody the national thinking and cultural heritage of peoples, thereby demonstrating how they perceive and interpret the concept of friendship. Consequently, an analysis of proverbs concerning friendship in Korean and Uzbek offers a more profound comprehension of the cultures, values, and social relationships of these two nations.

The question of how each nation understands and values friendship through proverbs is a pressing one. In the Korean language, proverbs pertaining to friendship frequently allude to harmony and loyalty within society, whereas in Uzbek proverbs, the emphasis is on the significance of friendship in life and its potency. This article presents a comparative analysis of friendship-related proverbs in both languages, exploring each culture's unique approach to the concept of friendship. This research not only examines how Korean and Uzbek proverbs express friendship but also sheds light on the cultural and social factors behind them. The study makes a significant contribution to the field of comparative linguistics and enhances our understanding of cultural differences.

### **Literature Review and Methodology**

The concept of friendship manifests differently in the cultures and traditions of various nations, and this is reflected in their proverbs as well. While previous studies have analyzed friendship-related proverbs in different languages, comprehensive research comparing Korean and Uzbek proverbs is still lacking. This article thus presents a comparative analysis of friendship proverbs in both languages.

A proverb (from the Latin "proverbium") is defined as a well-known, frequently repeated, and clearly stated expression that conveys wisdom based on human experience or practical knowledge. Renowned linguist W. Mieder defines a proverb in his book as follows: "A proverb is a short, universally known phrase that encapsulates the wisdom, truth, morality, and traditional views of the people, expressed in a metaphorical, fixed, and memorable form, passed down from generation to generation."

Proverbs are expressions of life experiences accumulated over centuries. They represent conclusions drawn from constant daily observations and present these reflections in a complete, structured manner. The diversity of meanings in each word, the stability of expressions, and the consistency of form are the hallmarks of proverbs. However, depending on usage, the scope of their meanings continuously expands. This underscores the critical importance of the meticulous scrutiny of each word in a



proverb, ensuring a comprehensive understanding of its nuanced implications. It is noteworthy that certain words employed in proverbs have historically conveyed divergent meanings. Furthermore, it is important to acknowledge the influence of religious beliefs, lifestyles, cultures, and worldviews on proverbs, which are reflected in the proverbs studied in folkloristics.

In his study of proverbs, Doctor of Philology To'ra Mirzayev states the following: "The interest in proverbs from a literary perspective, their use to enhance the artistic quality of a work and ensure the fluency of artistic language, has always been the focus of word artists across time. A thorough examination of the works of Yusuf Khos Hajib, Ahmad Yasavi, Rabg'uziy, Lutfiy, Alisher Navoi, Babur, Abulg'ozi Bahodirxon, Munis, Ogahi, Nodira, Muqimiy, Furqat, Avaz, Hamza, Sadriddin Ayni, It is evident that numerous proverbs, at times in their original form and at times modified, are present in their works."

The Korean term "proverb" (조선어가 and 동문어) is first attested in historical documents and among the records of dynasties. A proverb is defined as a valuable linguistic heritage that has been transmitted orally from generation to generation, representing concise, simple, and polite expressions that accompany each nation's long history. The evolution of Korean folk proverbs can be delineated in several stages. The first dictionary of proverbs in the Korean language, compiled by 최원식 and 조선어 in 1913, contains over 900 proverbs. The collection of proverbs by Kim Sang-gi, published in 1922, encompasses approximately 1,500 proverbs. The collection of proverbs by 진성기, published in 1959, contains more than 400 proverbs. In addition, the seminal work of Choi Chang, entitled "Proverbs of Women" (1993) and "Dictionary of Animal Proverbs" (1995), further expanded the corpus.

전윤진 (Jeon Yun-jin) says, "A proverb is a word whose origin is unknown, and it contains the thoughts and lifestyle of the elderly. Proverbs are often phrases that have been preserved for a long time or words spoken by famous people."

임무철 (Im Mu-chil) writes: "Sayings and proverbs are part of linguistic folklore, and they often contain more general and universal meanings than proverbs. On the other hand, proverbs are characterised by their local and temporal limitations."

남윤신 (Nam Yun-shin) says, "A proverb reflects the wisdom, way of thinking and values of people's lives, which are naturally widely spread among people."

박 잔연 (Park Jan-yeon) explains, "Both proverbs and sayings contain exemplary meanings. They are part of linguistic folklore, but compared to proverbs, sayings are more general and universal. On the other hand, proverbs have more local and temporal limitations,"

남윤신 (Nam Yun-shin) further emphasises: "A proverb is naturally formed and widely spread among the people, reflecting the wisdom, way of thinking and values of the people's life."

In the context of Korean proverbs, the notion of friendship is predominantly linked to the concepts of social harmony and long-term loyalty. A pertinent example of this is

the proverb “친구 따라 강남간다” (You follow your friend to Gangnam), which underscores the impact of friends on an individual’s life. This proverb serves to highlight the significance of group membership within the Korean societal framework. Furthermore, the proverb “가가재금은 게편이라” (A crab always supports its own kind) implies an obligation of mutual support among friends.

In Uzbek folk proverbs, the concept of friendship is expressed as being based on love, loyalty, and assistance. For example, proverbs such as:

“Do’sting bo’lsa, darding bo’lmas” (If you have a friend, you will have no troubles) or

“Do’st – omonat, dushman – g’animat” (A friend is a trust, an enemy is a prize) highlight the importance of friendship (see, for example, Do’sting bo’lsa, darding bo’lmas, Do’st – omonat, dushman – g’animat ).

Furthermore, proverbs such as “Yaxshi do’st – boshdagi toji, yomon do’st – boshdagi g’ov” (A good friend is like a crown on the head, a bad friend is like a yoke on the head) and “Do’st – do’sting ko’zgusi.”

“A friend is the mirror of a friend” underscores the significance of discerning friends and the potential consequences of this choice.

This literature review demonstrates that while the concept of friendship is inherently similar in both languages, their semantic and cultural aspects exhibit significant differences. The Korean language elucidates the concept of friendship through the lenses of loyalty and group affiliation, while the Uzbek language places greater emphasis on affection and sincere relationships.

## Results and Discussions

The present study, an investigation into the reflection of the concept of friendship in proverbs in the Korean and Uzbek languages, has yielded the following conclusions:

✓ **The following discourse will examine the common and distinctive aspects of the concept of friendship**

The proverbial wisdom of various languages offers a multifaceted perspective on the concept of friendship, encompassing notions of loyalty, testing, mutual benefit, and social solidarity.

In the context of Korean proverbs, the concept of friendship is elucidated through the lenses of societal belonging and long-term loyalty. A proverb that exemplifies this is “친구는 오래 사귄수록 좋다” (A friend is better the longer you stay friends), which signifies the notion that the strength of a friendship increases over time. It emphasises the value of lasting relationships and the deeper bond that develops as time passes.

The proverb “오랜 친구가 진정한 친구다” (An old friend is a true friend) highlights the value of long-standing friendships, suggesting that the depth of a true friendship is cultivated over time.

Another proverb, “같이 길을 가려면 친구를 잘 사귀어라” (If you want to walk the road together, choose your friends wisely), underscores the significance of selecting loyal and trustworthy friends for long-term companionship and loyalty.

In contrast, Uzbek proverbs articulate friendship as a concept founded on sincerity, loyalty, and affection. One such proverb, “Do’st – qozon, ichingdagini suzib oladi” (A friend is like a pot, they can fish out what’s inside you), highlights the profound understanding that a sincere friend possesses of a person's emotions and thoughts. It implies that true friends are able to sense and understand the innermost feelings of one another.

“Do’st do’stga suyanib yashaydi” (A friend lives relying on another friend) – This proverb signifies that true friendship is based on mutual trust and support, where friends help and rely on each other through life’s challenges.

“Do’st achitib gapirar, dushman – maqtab” (A friend speaks harshly, but a foe praises) – This proverb emphasizes that a sincere friend tells you the truth, even if it is difficult, because they wish the best for you. In contrast, an enemy may flatter you, but not out of genuine care. Many similar proverbs could be cited, each reinforcing the value of honesty, trust, and support in genuine friendship.

## 2) The Universal and Distinctive Aspects of the Concept of Friendship

With regard to the common aspects, both languages associate friendship with loyalty, testing, and human relationships.

For instance, an examination of Korean folk proverbs may provide a fruitful avenue for exploration. “백지장도 맞들면 낫다” (Even lifting a sheet of paper is easier when done together) – this proverb highlights the importance of collaboration, teamwork, and the value of working together in friendship and society.

“멀리 있는 친척보다 가까운 이웃이 낫다” (A close neighbor is better than a distant relative) – This proverb illustrates the significant role of friends and close social connections in one’s life, emphasizing the importance of proximity and everyday support over distant relationships.

The maxim “같이 길을 가려면 친구를 잘 사귀어라” (If you want to walk the road together, choose your friends wisely) – this proverb conveys the significance of long-term friendship and loyalty.

For instance, a case study of Uzbek folk proverbs may provide illuminating insights, “Do’sting ko’p bo’lsa, yo’ling keng bo’ladi” (If you have many friends, your path will be wider) highlights the significance of friendship in social life.

“Og’aynili joyda to’kinlik bo’lur” (In a place of friendship, there will be abundance) – This suggests that living with a close-knit community or friends brings prosperity and blessings.

“Birlik bo’lsa, tiriklik bo’ladi” (where there is unity, there is life), serves to underscore the profound impact of solidarity, companionship, and cooperation on the vitality of a community.

The findings of the research suggest that the concept of friendship in Korean and Uzbek proverbs has been shaped based on analogous cultural and social values. A close examination of proverbial collections in both languages reveals that friendship is reflected through common aspects such as loyalty, assistance, and testing. Furthermore, an analysis of these proverbs reveals similarities in their interpretation and usage.

Korean: “믿는 도끼에 발등 찍힌다” (The axe you trust may strike your foot).

Uzbek: “Do‘st yuzli, dushman ko‘ngilli bo‘lmasin” (A friend may betray, but an enemy will never be kind). In both cultures, it is emphasized that there is a possibility of betrayal by a trusted friend.

Korean: “벗이 없으면 행복도 없다” (Without a friend, there is no happiness).  
Uzbek: “Do‘sting bo‘lsa, darding bo‘lmas” (If you have a friend, you won't have sorrow). In both cultures, the presence of a friend is considered an essential part of a person's life, highlighting the importance of friendship for happiness and emotional well-being.

Korean: “우정은 어려울 때 진가를 발휘한다” (Friendship shows its true value in difficult times).

Uzbek: “Do‘st boshga kulfat tushganda bilinadi” (A friend is known when trouble strikes).

In both languages, the true test of friendship is understood to be revealed during hard times, with the idea that a genuine friend stands out in moments of difficulty.

The analysis of proverbial wisdom in Uzbek and Korean demonstrates the existence of shared conceptual frameworks within these languages.

## Conclusion

This article employs an analytical approach to explore the cultural and linguistic characteristics of the concept of friendship as manifested in folk proverbs of the Korean and Uzbek languages. A comparison of the two cultures reveals the presence of common concepts, with friendship being interpreted as a significant social phenomenon. In the context of Korean culture, friendship is intertwined with concepts of long-term loyalty and social group affiliation, while in Uzbek culture, it is characterized by qualities such as honesty, compassion, and selflessness.

## References:

- [1] Mirzayev T. “Uzbek folk proverbs,” There is a difference between words and words & Umid Bekmuhammad. Uzbek proverbs that are spread around the world. Tashkent: *Sharq*, 2016.
- [2] Ermetova J. “Principles of modern punctuation and intonation as a means of punctuation to convey the semantic significance of speech,” *Electronic journal of actual problems of modern science, education and training*. December, 12/1, 2021, p. 32.
- [3] <https://encykorea.aks.ac.kr>
- [4] <https://naver.com>
- [5] 한국민속대백과사전 (Koreys Xalq Ensiklopediyasi): <https://folkency.nfm.go.kr>
- [6] Mirzayev T., Musoqulov A., Sarimsoqov B. “Uzbek folk proverbs,” Tashkent: *Sharq*, 2005.
- [7] Ermetova J. “Linguo-culturology and cross cultural communication as new linguistic trends in foreign language teaching,” *Electronic journal of actual problems of modern science, education and training*. January, Issue 1, 2017, p. 79.
- [8] Ermetova J. and Masharipov J. “Traditional and conceptual metaphor in the English language,” *Electronic journal of actual problems of modern science, education and training*. January, Issue 1, 2018, p. 119.



UDC: 8, 81, 811.111, 811.161.1

## THE CONCEPT OF “GOOD AND EVIL” IN RUSSIAN AND ENGLISH LANGUAGES: A COMPARATIVE ANALYSIS OF PAREMIOLOGY

**Mambetova Roza Baltabaevna**

*Karakalpak State University named after Berdakh  
(Nukus)*

[roza.mambetova.66@bk.ru](mailto:roza.mambetova.66@bk.ru)

**Jumamuratova Ramiza Adilmuratovna**

*Karakalpak State University named after Berdakh  
(Nukus)*

[ramizajumamuratovaazamat@mail.ru](mailto:ramizajumamuratovaazamat@mail.ru)

**Annotatsiya.** Maqola paremiologiya asosida rus va ingliz tillarida “yaxshi” va “yomon” tushunchalarini qiyosiy tahlil qilishga bag‘ishlangan. Maqol va matallar xalq donoligining bir shakli sifatida turli xalqlarning asosiy axloqiy qadriyatlarini va madaniy munosabatlarini aks ettiradi. Asarda rus va ingliz tillarida yaxshilik va yomonlik talqinidagi o‘xshashlik va farqlar hamda ularning so‘zlovchilarning dunyoqarashiga ta’siri o‘rganiladi. Rus tilida ezgulik an’anaviy ravishda fidoyilik, kollektivizm va ma’naviy qadriyatlar bilan bog‘liq bo‘lsa, ingliz an’analarida ko‘proq shaxsiy javobgarlik, amaliy foyda va ijtimoiy adolat bilan bog‘liq. Maqollarni tahlil qilish shuni ko‘rsatadiki, axloqiy kategoriyalarning universalligiga qaramay, ularning madaniy talqini sezilarli darajada farq qiladi.

**Kalit so‘zlar:** yaxshilik, yomonlik, paremiologiya, maqollar, maqollar, qiyosiy tahlil, rus tili, ingliz tili, tilshunoslik, dunyoning milliy rasmi.

**Аннотация.** Статья посвящена сравнительному анализу концептов “добро” и “зло” в русском и английском языках на основе паремииологии. Пословицы и поговорки как форма народной мудрости отражают ключевые моральные ценности и культурные установки разных народов. В работе рассматриваются сходства и различия в трактовке добра и зла в русском и английском языках, а также их влияние на мировоззрение носителей языка. В русском языке добро традиционно ассоциируется с самопожертвованием, коллективизмом и духовными ценностями, тогда как в английской традиции его чаще связывают с индивидуальной ответственностью, практической выгодой и социальной справедливостью. Анализ пословиц показывает, что, несмотря на универсальность моральных категорий, их культурная интерпретация существенно различается.

**Ключевые слова:** добро, зло, паремииология, пословицы, поговорки, сравнительный анализ, русский язык, английский язык, лингвокультурология, национальная картина мира.

**Abstract.** The article is devoted to a comparative analysis of the concepts of “good” and “evil” in Russian and English languages based on paremiology. Proverbs and sayings as a form of folk wisdom reflect key moral values and cultural attitudes of different nations. The work examines the similarities and differences in the interpretation of good and evil in Russian and English, as well



as their influence on the worldview of speakers. In Russian, goodness is traditionally associated with self-sacrifice, collectivism, and spiritual values, whereas in the English tradition, it is more often associated with individual responsibility, practical benefit, and social justice. An analysis of proverbs demonstrates that, despite the universality of moral categories, their cultural interpretation varies significantly.

**Keywords:** *good, evil, paremiology, proverbs, sayings, comparative analysis, Russian language, English language, linguacultural studies, national picture of the world.*

## Introduction

Good and evil are fundamental moral categories that determine human behavior and regulate social relations. They are an integral part of the worldview of any nation, reflected in language, culture, and folklore. Proverbs and sayings as part of paremiology are short and expressive linguistic forms that convey folk wisdom and experience accumulated over centuries [1].

Their study allows us to gain a deeper understanding of how different peoples interpret and comprehend the concepts of good and evil, as well as to identify the cultural and ideological features of a particular linguacultural community.

This article is devoted to a comparative analysis of the concepts of “good” and “evil” in Russian and English paremiology. Let us consider what key values and norms are enshrined in proverbs of the two languages, what similarities and differences can be traced in their interpretation, and how national culture influences the expression of these moral categories.

Concepts of "good" and "evil" are universal and meet in every language, but their content and interpretation can vary depending on cultural and religious traditions [1].

In Russian, good is often associated with self-sacrifice, collectivism, and spiritual values, while evil is associated with the destruction of harmony, injustice, and sinfulness. In the English tradition, good is more focused on individual responsibility, practical benefits, and positive interaction with the outside world, while evil is seen as a violation of social norms and personal boundaries [2].

Proverbs are one of the most visual ways of representing the concepts of “good” and “evil”. They contain value judgments, warnings, and advice based on folk experience. Analysis of proverbs helps to identify the peculiarities of the worldview of native speakers and understand what values they consider fundamental [2].

In the Russian language, goodness is perceived as the highest moral value, requiring selfless actions, self-sacrifice, and justice from a person. This is connected with the traditionally collectivist structure of Russian culture, which values self-sacrifice, selflessness, and the willingness to help even to one’s own detriment [3].

*Russian proverbs that confirm this approach:*

- *“Доброе слово и кошке приятно”* - even a little kindness is appreciated.
- *“Доброе дело само себя хвалит”* - true virtue needs no recognition.
- *“Чем больше отдаёшь, тем больше получаешь”* - the idea of mutual exchange of good.

- **“Доброе дело — не тяжкий труд”** - *doing good is not difficult, and it is everyone’s duty.*
- **“Делай добро и бросай его в воду”** - *Don’t expect gratitude for good deeds, your help should be selfless.*
- **“Добро без ума — глупость”** - *even a good deed requires wisdom, otherwise it can cause harm.*
- **“От добра добра не ищут”** - *There is no point in seeking benefits from good deeds, since true goodness should not be selfish.*
- **“Кто людям добра желает, тому оно и бывает”** - *Good comes back to those who do good deeds.*

Many Russian proverbs and sayings emphasize that virtue is not a choice, but a person’s duty, which is regulated by the norms of society.

In the Russian worldview, goodness is closely connected with conscience, honor and moral responsibility to the collective [4].

The English tradition, formed under the influence of an individualistic worldview, proceeds from the fact that good is a personal decision of a person, and not an obligation imposed by society.

Unlike Russian culture, where good deeds are perceived as a social duty, in the English-speaking world, virtue is often seen as a conscious choice that brings inner satisfaction [5].

***This is reflected in English proverbs:***

- **“Virtue is its own reward”** (Virtue is its own reward) - good deeds are valuable in themselves, even if they do not bring material benefit.

- **“No act of kindness, no matter how small, is ever wasted”** - (No act of kindness, no matter how small, is wasted) - every act of kindness counts.

- **“A good deed is never lost”** - (A good deed is never wasted) – an analogue of the Russian proverb “What goes around comes around.”

- **“The best way to cheer yourself up is to try to cheer someone else up”** - (The best way to cheer yourself up is to try to cheer someone else up) – kindness brings joy not only to others, but also to the person himself.

- **“Kindness begets kindness”** - (Kindness begets kindness) – reminds one of the Russian saying “What goes around comes around”, emphasizing the reciprocity of good deeds.

- **“Goodness brings its own reward”** - (Goodness is self-rewarding) – doing good is beneficial for the person himself, as it gives him moral satisfaction.

Thus, in English-speaking culture, goodness is not a social duty, but a personal choice that benefits both others and the person himself.

Another important difference between the Russian and English approaches to kindness is the attitude towards gratitude.

In Russian, there is an idea that true goodness must be selfless, and one should not expect gratitude for good deeds [6]:

- **“Делай добро, не жди благодарности”** – it is important to do good for the sake of good itself, and not for recognition.

- **“Не жди добра за добро”** – *good deeds do not always receive kindness in return.*

- **“Добро помнится недолго, а зло – вечно”** – People remember bad deeds more often than good ones.

English culture, on the contrary, is more pragmatic in this matter. Although it also emphasizes the importance of selfless virtue, the idea of justice and recognition of merit is expressed more strongly [6]. For example:

- **“One good turn deserves another”** (Доброе дело заслуживает ответного доброго дела)- gratitude for kindness is considered the norm.

- **“What goes around, comes around”**- (Что посеешь, то и пожнешь) – good comes back, but so does evil.

- **“Do unto others as you would have them do unto you”** (Поступай с другими так, как хочешь, чтобы поступали с тобой) – the golden rule of morality, which suggests that goodness should be mutual.

Based on this, we can conclude that in Russian culture, goodness is perceived as selfless and not requiring a response, while in English culture it is perceived as an act that is likely to be rewarded.

The Russian tradition of goodness was largely formed under the influence of Orthodoxy, where goodness is associated with divine grace, self-sacrifice and forgiveness [7]:

- **“Милость Божья велика”** - Good comes from God, and it is infinite.

- **“Бог терпел и нам велел”** - Goodness requires patience and humility.

- **“Не суди, да не судим будешь”** – doing good means not judging others.

In the English-speaking world, the concept of good has been heavily influenced by the Protestant ethic, which views goodness as a personal choice that leads to success and well-being:

- **“God helps those who help themselves”** (Бог помогает тем, кто помогает себе) – Virtue is associated with active action, not with passive waiting.

- **“Hard work and virtue go hand in hand”** (Усердный труд и добродетель идут рука об руку) – goodness is directly related to hard work and self-development.

- **“Do good and forget it”** (Делай добро и забудь о нем) – good deeds should not be done for the sake of praise.

Speaking about evil, it can be noted that in the Russian language it is considered as a destructive force that inevitably leads to negative consequences [8]. Russian proverbs often warn about the consequences of evil deeds:

- **“Что посеешь, то и пожнешь”** - analogue of English **“You reap what you sow”**.

- **“Кто другому яму роет, сам в неё попадёт”** — an evil intrigue turns against the person himself.

- **“Зло порождает зло”** — violence only leads to more violence.

**The idea of inevitable retribution for evil is also present in English culture:**

- **“What goes around, comes around”** (Что посеешь, то и пожнешь)- karmic principles.

**“Evil begets evil”** (Зло порождает зло)- — repeats the Russian idea of a vicious circle of crimes.

**“An eye for an eye, a tooth for a tooth”** (Око за око, зуб за зуб) — the idea of fair punishment.

Here it can be noted that Russian paremiology places greater emphasis on the moral condemnation of evil, while English paremiology is more focused on cause-and-effect relationships and retribution.

***Key similarities and differences:***

**Similarities:**

- Both languages emphasize the cause-and-effect relationships between good, evil and their consequences.
- In both languages, good is associated with correct moral choices, and evil with the violation of norms.
- Proverbs contain instructions and warnings that help people navigate through life.

**Differences:**

- In Russian, good is closely associated with collective values, mutual assistance and sacrifice, whereas in English it is more often individualistic and pragmatic.
- In Russian, evil is associated with the violation of spiritual and social norms; in English, it is associated with personal responsibility and consequences
- English paremiology includes more expressions that reflect a rational attitude towards good and evil, while Russian paremiology relies on emotional and moral categories.

The concepts of “good” and “evil” are central to both languages, but their interpretation varies depending on cultural and historical context.

Russian paremiology emphasizes collectivism, spiritual values, and sacrifice, while the English tradition emphasizes individual responsibility, pragmatism, and social justice. Despite the differences, both languages recognize the importance of good and the inevitability of retribution for evil, as evidenced by the many similar proverbs.

**References:**

- [1] Abdullina G.M. “Russian culture through the prism of language,” - Kazan: *Kazan Federal University*, 2018.
- [2] Barkhudarov L.S. “Language and Translation: Issues of General and Specific Theory of Translation,” - M.: *Nauka*, 1975.
- [3] Galperin I.R. “Text as an object of linguistic research,” - M.: *Nauka*, 1981.
- [4] Likhachev D.S. “The Culture of Ancient Rus',” - L.: *Nauka*, 1971.
- [5] Mikhailova M.S. “Concepts of good and evil in Russian and English vocabulary,” - St. Petersburg: *Philological faculty of St. Petersburg State University*, 2012.
- [6] Sternin I.A. “Theory of translation in the context of culture,” - Voronezh: *VSU*, 2009.
- [7] Stepanov Yu.S. “Constants: Dictionary of Russian Culture,” - M.: *Academic Project*, 2004.
- [8] Schweitzer I.Ya. “Psychology of intercultural communication,” - M.: *Higher School*, 1993.



UDC: 004.8, 801.8, 81, 81.32

## CONTEXT-FREE GRAMMAR BASED PARSING ALGORITHM FOR SIMPLE SENTENCES IN THE UZBEK LANGUAGE

**Maqsud Siddiqovich Sharipov**

Associate Professor, Department of  
Computer Science, Urgench State University  
named after Abu Rayhan Biruni  
[m.sharipov@urdu.uz](mailto:m.sharipov@urdu.uz)

**Ixtiyor Davlatyorovich Avezmatov**

Lecturer, Department of Computer Science,  
Urgench State University named after Aby  
Rayhan Biruni  
[ixtiyoravezmatov07@gmail.com](mailto:ixtiyoravezmatov07@gmail.com)

**Annotatsiya.** Tabiiy tilni qayta ishlash sohasida o‘zbek tilidagi sodda gaplarni tahlil qilish katta ahamiyatga ega. Ushbu maqola kontekstsiz grammatika asosida oddiy o‘zbek tilidagi gaplarni tahlil qilish algoritmini ishlab chiqish muammosini hal qilishni taklif qiladi. O‘zbek tilining sintaktik qoidalari Xomskiyning kontekstsiz grammatikasi bo‘yicha rasmiylashtirilib, algoritmik yechimlar bilan bir qatorda tahlil qilish daraxtlari ham ishlab chiqiladi. Tadqiqot natijalari shuni ko‘rsatadiki, ishlab chiqilgan model grammatikani tekshirish, avtomatlashtirilgan tarjima va tabiiy tilni qayta ishlash tizimlarida samarali qo‘llanilishi mumkin.

**Kalit so‘zlar:** o‘zbek tili, oddiy jumlarlar, tahlil qilish algoritmi, kontekstsiz grammatika, Xomskiy grammatikasi, tabiiy tilni qayta ishlash.

**Аннотация.** Анализ простых предложений на узбекском языке имеет большое значение в области обработки естественного языка. В данной статье предлагается решение проблемы разработки алгоритма синтаксического анализа простых узбекских предложений на основе контекстно-свободной грамматики. Синтаксические правила узбекского языка формализуются в соответствии с контекстно-свободной грамматикой Хомского, и разрабатываются деревья синтаксического анализа вместе с алгоритмическими решениями. Результаты исследования показывают, что разработанная модель может эффективно применяться в проверке грамматики, автоматическом переводе и системах обработки естественного языка.

**Ключевые слова:** узбекский язык, Простые предложения, Алгоритм синтаксического анализа, Контекстно-свободная грамматика, Грамматика Хомского, Обработка естественного языка.

**Abstract.** Analyzing simple sentences in the Uzbek language is of great importance within the field of Natural Language Processing (NLP). This paper proposes a solution to the problem of developing a parsing algorithm for simple Uzbek sentences based on Context-Free Grammar (CFG). The syntactic rules of Uzbek are formalized according to Chomsky’s context-free grammar, and parsing trees along with algorithmic solutions are developed. The research findings



demonstrate that the developed model can be effectively applied in grammar checking, automated translation, and NLP systems.

**Keywords:** *Uzbek language, Simple sentences, Parsing algorithm, Context-Free Grammar (CFG), Chomsky grammar, Natural Language Processing (NLP).*

## Introduction

Syntactic analysis is one of the fundamental stages in the field of Natural Language Processing (NLP). In this process, the syntactic relationships between words are identified, and the structural components of a sentence, along with their grammatical roles, are determined. The Uzbek language, being an agglutinative language, has unique grammatical features that influence the parsing process. The morphological and syntactic characteristics of the language require a specialized approach to building a parsing model. In Uzbek, words are inflected through suffixes, making morphological analysis an integral part of the parsing process. Additionally, the free word order of Uzbek necessitates flexibility in parsing algorithms.

For successful syntactic analysis, a deep understanding of noun phrases, verb components, and auxiliary word structures in Uzbek is essential. This paper explores methods for developing a syntactic analysis model for simple Uzbek sentences based on Context-Free Grammar (CFG), including grammatical rules, parsing algorithms, and their adaptation to the language. Furthermore, it discusses the challenges encountered in parsing different Uzbek sentence constructions and the solutions proposed to address them.

## Literature Review

Among the studies on syntactic analysis in the Uzbek language, M.A. Rakhmonova's paper "*A Syntactic Parsing Model for Simple Sentences in Uzbek*" [1, 2] stands out. This research presents an algorithm and its stages for the syntactic analysis of simple Uzbek sentences, formalizing syntactic rules based on Chomsky's Context-Free Grammar (CFG). The study compares Uzbek and English models, demonstrating their application in grammar checking and NLP systems.

Other significant studies in this field include research on CFG-based syntactic analysis for Turkic languages. For instance, the paper "*Context-Free Grammar for Turkish*" by Dönmez and Adalı [3] investigates the syntactic features of Turkish, including free word order and converbs, using CFG rules. Similarly, Zafer's study, "*A Generic Syntactic Parser for Turkic Languages*" [4, 5], introduces a universal syntactic parser for Turkish and Turkmen, assessing the efficiency of CFG rules and parsing algorithms.

Kazakh researchers Sharipbay et al. have published "*Syntax Parsing Model of Kazakh Simple Sentences*" [6, 7], where simple sentences in Kazakh are analyzed using CFG-based parsing trees and ontological models.

These studies emphasize the importance of CFG in formalizing the syntactic structures of Turkic languages and demonstrate its effectiveness in grammar checking, machine translation, and other NLP applications.

## Analysis and Results

*General Understanding of Context-Free Grammar (CFG).*

Context-Free Grammar (CFG) is a formal grammar model widely used in Natural Language Processing (NLP) to define the syntactic structure of words. CFG consists of the following four elements:

$$G = \langle N, T, P, S \rangle$$

Where:

N – A set of non-terminal symbols (e.g., S – sentence, NP – noun phrase, VP – verb phrase).

T – A set of terminal symbols (actual words, e.g., “boy”, “school”, “came”).

P – A set of production rules (e.g.):

$$S \rightarrow NP VP$$

$$NP \rightarrow N \mid \text{Pron}$$

$$VP \rightarrow V \mid V NP$$

S – The starting symbol (represents the overall sentence structure).

### *Syntactic Features of Simple Sentences in Uzbek.*

To model simple sentences in Uzbek, the following formal grammar rules are used. This CFG includes 49 fundamental types of Uzbek simple sentences, with each rule separated by the “|” symbol:

$S \rightarrow E \mid EK \mid ETK \mid EHK \mid ETHK \mid EHTK \mid EATK \mid HETK \mid TK \mid HK \mid AK \mid THK \mid HTK \mid ATK \mid EAK \mid HEK \mid AEK \mid HAK \mid TAK \mid EHAKE \mid EAK \mid HEAK \mid ATHK \mid AHK \mid HATK \mid THAK \mid AEHK \mid ETHAK \mid HETAK \mid HAETK \mid EAHTK \mid AETHK \mid EHTAK \mid TAHK \mid HTAK \mid AHEAK \mid AETAKE \mid AAK \mid AAKE \mid HAAK \mid AEATK \mid ATHAK \mid AATK \mid AETAKE \mid AAHEK \mid AEHAK \mid AHATK \mid AATK$

Table 1 below provides examples of some Uzbek simple sentence structures along with their corresponding CFG representations.

**Table 1.** Uzbek simple sentence structures along with their corresponding CFG representations.

<i>Examples and CFG Representation</i>	
1. “Havo.”	$S \rightarrow E \quad E \rightarrow \text{“Havo”}$
2. “O‘quvchilar o‘qidi.”	$S \rightarrow EK \quad E \rightarrow \text{“O‘quvchilar”} \quad K \rightarrow \text{“o‘qidi”}$
3. “Usta mashinani ta‘mirladi.”	$S \rightarrow ETK \quad E \rightarrow \text{“Usta”} \quad T \rightarrow \text{“mashinani”} \quad K \rightarrow \text{“ta‘mirladi”}$
4. “Sportchi stadionda yugurdi.”	$S \rightarrow EHK \quad E \rightarrow \text{“Sportchi”} \quad H \rightarrow \text{“stadionda”} \quad K \rightarrow \text{“yugurdi”}$
5. “Sotuvchi mevani bozorda sotdi.”	$S \rightarrow ETHK \quad E \rightarrow \text{“Sotuvchi”} \quad T \rightarrow \text{“mevani”} \quad H \rightarrow \text{“bozorda”} \quad K \rightarrow \text{“sotdi”}$
6. ”Bog‘bon daraxtda olma uzdi.”	$S \rightarrow EHTK \quad E \rightarrow \text{”Bog‘bon”} \quad H \rightarrow \text{”daraxtda”} \quad T \rightarrow \text{”olma”} \quad K \rightarrow \text{”uzdi”}$

The following table represents non-terminal symbols used in the context-free grammar (CFG) model for Uzbek simple sentences, along with their definitions and examples.

**Table 2.** Non-terminal symbols, their meanings, and examples.

Non-Terminal Symbol	Meaning	Example
<b>E (Ega - Subject)</b>	Represents the subject of the sentence, usually at the beginning. It is often a noun, pronoun, or noun phrase indicating who or what performs the action.	“ <i>Bolalar</i> ” (Children)
<b>K (Kesim - Predicate)</b>	Represents the main verb (predicate) of the sentence, usually at the end. It describes an action, state, or existence.	“ <i>o‘ynadi</i> ” (played)
<b>A (Aniqlovchi - Modifier/Qualifier)</b>	A word that modifies or describes another word, often appearing before the noun it qualifies. It can be an adjective, numeral, or demonstrative word.	“ <i>chiroyli</i> ”
<b>T (To‘ldiruvchi - Object)</b>	Represents the object of the sentence, which is affected by the action of the verb. It usually precedes the predicate and is often a noun or noun phrase with case suffixes (-ni, -ga, etc.).	“ <i>kitobni</i> ”
<b>H (Hol - Adverbial Modifier)</b>	Expresses the manner, place, time, or condition of an action. It typically appears before the predicate.	“ <i>maktabda</i> ”

These non-terminal symbols and their respective meanings play a key role in defining Uzbek sentence structures within the CFG framework.

### ***Building the Algorithm.***

The following code demonstrates how to perform syntactic parsing of a sentence using Context-Free Grammar (CFG) with the Natural Language Toolkit (NLTK) library. Below is a detailed explanation of each part of the code and its functionality.

#### **1. NLTK and CFG**

- **NLTK Library:** A widely used library in Python for Natural Language Processing (NLP). It provides various tools, including grammars, parsers, and statistical models.
- **CFG (Context-Free Grammar):** A set of syntactic rules that define the structure of a language. Parsing is performed using these rules. Each rule consists of a start symbol (non-terminal) and a sequence of terminal or other non-terminal symbols.

#### **2. Defining Grammar Rules**

In the first part of the code, the grammar rules are defined as follows:

```
import nltk

grammar = nltk.CFG.fromstring("""
    S -> E T H K
    E -> "Sotuvchi"
    T -> "mevani"
    H -> "bozorda"
    K -> "sotdi"
    """)
```

- **S** – The start symbol, representing the main sentence structure.
- **E, T, H, K** – Non-terminal symbols, each mapped to a specific terminal word:
  - **E** → “Sotuvchi” (Seller)

- T → “mevani” (The fruit)
- H → “bozorda” (At the market)
- K → “sotdi” (Sold)

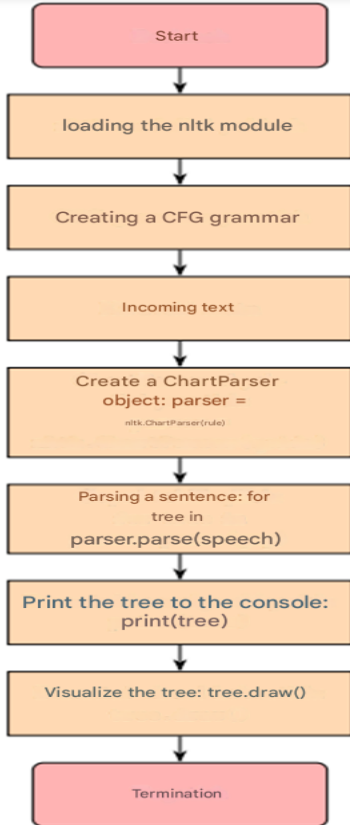
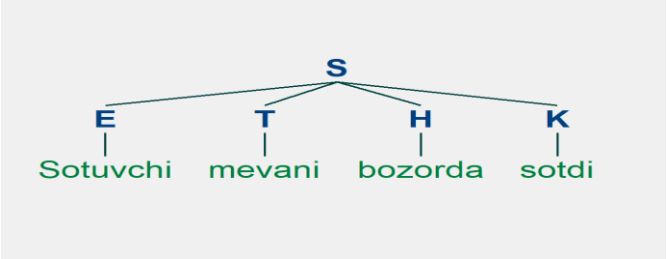
<pre>import nltk grammar = nltk.CFG.fromstring(""" S -&gt; E T H K E -&gt; "Sotuvchi" T -&gt; "mevani" H -&gt; "bozorda" K -&gt; "sotdi" """) sentence = ['Sotuvchi', 'mevani', 'bozorda', 'sotdi'] parser = nltk.ChartParser(grammar) for tree in parser.parse(sentence):     print(tree)     tree.draw()</pre>	 <pre> graph TD     Start([Start]) --&gt; Loading[loading the nltk module]     Loading --&gt; Creating[Creating a CFG grammar]     Creating --&gt; Incoming[Incoming text]     Incoming --&gt; Create[Create a ChartParser object: parser = nltk.ChartParser(rule)]     Create --&gt; Parsing[Parsing a sentence: for tree in parser.parse(speech)]     Parsing --&gt; Print[Print the tree to the console: print(tree)]     Print --&gt; Visualize[Visualize the tree: tree.draw()]     Visualize --&gt; Termination([Termination])     </pre>
	

### 3. Defining the Sentence and Parsing

```
sentence = ['Sotuvchi', 'mevani', 'bozorda', 'sotdi']
```

- sentence: This is a list representing a sentence. Each element corresponds to a terminal word that matches the defined grammar rules.
- The ChartParser algorithm is used to parse the sentence:

```
parser = nltk.ChartParser(grammar)

for tree in parser.parse(sentence):
    print(tree)
    tree.draw()
```

- nltk.ChartParser: This algorithm parses the given sentence based on the defined CFG rules. It stores partial parsing results in a structure called a "chart", allowing step-by-step reconstruction of the syntactic structure.
- For loop: If multiple parsing trees exist (e.g., if multiple syntactic structures are valid under the given grammar), the loop iterates through and displays each one.
- tree.draw(): This function visualizes the parse tree in a graphical format (if a graphical environment is available).

#### 4. ChartParser Algorithm

The ChartParser algorithm operates as follows:

- **Initialization:** The algorithm starts by scanning the first word of the sentence, searching for matching terminal rules, and adding them to a data structure called a chart.

- **Intermediate Results:** At each step, grammar rules (productions) are applied to expand the existing partial results. If a non-terminal's left-hand side matches a sequence of terminals or other non-terminals, it is processed as a single unit.

- **Final Result:** Once the end of the sentence is reached, if the start symbol (S) forms a complete parse tree, the full syntactic structure of the sentence is recognized.

This method is particularly efficient for complex or ambiguous grammatical rules, as it stores intermediate results and prevents redundant computations, ensuring optimized parsing performance.

#### Conclusion

This study focuses on developing a parsing algorithm based on Context-Free Grammar (CFG) for the syntactic analysis of simple sentences in the Uzbek language. The paper provides an in-depth examination of syntactic analysis stages within Natural Language Processing (NLP), particularly analyzing the structural components of a sentence, their relationships, and grammatical roles.

Considering the agglutinative nature of Uzbek, its free word order, and morphological complexity, a specialized model was developed using Chomsky's context-free grammar. The study presents examples of simple sentences, illustrating their structure explicitly, including subject (E), predicate (K), modifier (A), object (T), and adverbial phrase (H). The paper also provides tables and practical examples to clearly demonstrate grammatical constructions and parsing results, making it valuable for both theoretical and applied research.

Additionally, the application potential of this model in grammar checking, machine translation, and NLP systems has been thoroughly explored. This approach enables automatic syntactic analysis while accounting for the unique linguistic features of the Uzbek language. The results indicate that the developed parsing algorithm effectively identifies syntactic structures in simple sentences and opens up new opportunities in natural language processing.

In summary, this paper not only proposes an effective approach for syntactic analysis in the Uzbek language but also serves as a foundation for further research in linguistics and NLP. The findings of this study will be instrumental in advancing Uzbek machine translation, grammar analysis, and other language processing systems. Moreover, by deeply analyzing the language's complexity and unique characteristics, the study contributes to developing more precise and efficient linguistic models and grammar.

This research introduces 49 CFG rules, which can be utilized in artificial intelligence models for Uzbek language processing.

#### References:

- [1] Raxmonova Mohira Abdusattor qizi, "O'zbek tilidagi sodda gaplar uchun sintaktik parsing modeli," Toshkent, 2023.





- [2] Sharipov M. and Sobirov O. “Development of a Rule-Based Lemmatization Algorithm Through Finite State Machine for Uzbek Language,” in *CEUR Workshop Proceedings*, 2022, pp. 154 – 159.
- [3] DÖNMEZ İ. and ADALI E., “Contex Free Grammer For Turkish,” *Süleyman Demirel Üniversitesi Fen Bilimleri Enstitüsü Dergisi*, vol. 22, № 2, Jul. 2018, p. 552. DOI: 10.19113/sdufbed.34562.
- [4] Harun Reşit ZAFER “A generic syntactic parser for turkic languages,”
- [5] Sharipov M.S., Adinaev H.S., and Kuriyozov E.R., “Rule-Based Punctuation Algorithm for the Uzbek Language,” in *International Conference of Young Specialists on Micro/Nanotechnologies and Electron Devices, EDM*, 2024, pp. 2410 – 2414. DOI: 10.1109/EDM61683.2024.10615061.
- [6] Sharipbay A., Yergesh B., Razakhova B., Yelibayeva G., and Mukanova A. “Syntax parsing model of Kazakh simple sentences,” in *ACM International Conference Proceeding Series*, Association for Computing Machinery, Dec. 2019. DOI: 10.1145/3368691.3368745.
- [7] Maksud S., Elmurod K., Ollabergan Y., and Ogabek S., “UzbekVerbDetection: Rule-based Detection of Verbs in Uzbek Texts,” in *2024 Joint International Conference on Computational Linguistics, Language Resources and Evaluation, LREC-COLING 2024 - Main Conference Proceedings*, 2024, pp. 17343 – 17347.
- [8] Chomsky N. “Three Models for the Description of Language,” *IRE Transactions on Information Theory*, 1956.



## MODERN PROBLEMS OF PEDAGOGY AND PSYCHOLOGY

UDC: 37, 37.09, 378, 9

### STAGES OF ORGANIZING STUDENTS' INDEPENDENT EDUCATION IN GEOGRAPHY

**Abdimurotov Oybek Uralovich**

*Associate Professor, Doctor of Philosophy Pedagogical science (PhD), Head of the Geography Department at Chirchik State Pedagogical University*  
[o.abdimurotov@cspu.uz](mailto:o.abdimurotov@cspu.uz)

**Аннотация.** Ushbu maqola mustaqil ta'limni tashkil etish jarayonini va uning asosiy bosqichlarini ta'riflaydi. Maqolada ta'lim jarayonining samarali amalga oshirilishiga yo'l qo'yadigan muhim bosqichlar - maqsadni belgilash, topshiriqlarni ishlab chiqish, o'quv jarayonini tashkil etish, faoliyatni nazorat qilish, natijalarni tahlil qilish va yakunlash haqida batafsil ma'lumot berilgan. Har bir bosqichning ahamiyati, talabalar uchun bilimlarni mustahkamlash, yangi ko'nikmalarni o'zlashtirish va o'rganish jarayonini mustaqil ravishda boshqarish imkoniyatlarini yaratishdagi roli ko'rsatilgan.

**Калит so'zlar:** *Mustaqil ta'lim, ta'lim jarayoni, geografiya fani, ta'lim bosqichlari, maqsadni belgilash, izlanish, faoliyatni nazorat qilish, mustaqil izlanishlar, ko'nikmalarni rivojlantirish, tahlil qilish, ta'lim samaradorligi.*

**Аннотация.** Эта статья описывает процесс организации самостоятельного обучения и его основные этапы. В статье подробно рассматриваются важнейшие этапы, способствующие эффективной реализации учебного процесса, такие как постановка целей, разработка заданий, организация учебного процесса, контроль за деятельностью, анализ результатов и завершение. Описана роль каждого этапа в укреплении знаний студентов, освоении новых навыков и создании возможностей для самостоятельного управления процессом обучения.

**Ключевые слова:** *Самостоятельное обучение, учебный процесс, география, этапы обучения, постановка целей, исследование, контроль за деятельностью, самостоятельные исследования, развитие навыков, анализ, эффективность обучения.*

**Abstract.** This article describes the process of organizing independent education and its key stages. The article provides detailed information about important stages that ensure the effective implementation of the educational process: goal setting, developing assignments, organizing the educational process, monitoring activities, analyzing results, and concluding. The importance of each stage and its role in strengthening students' knowledge, acquiring new skills, and providing opportunities to manage the learning process independently are highlighted.

**Keywords:** *Independent education, educational process, geography, educational stages, goal setting, research, activity monitoring, independent research, skills development, analysis, educational effectiveness.*

## Introduction

The modern education system, including higher education in Uzbekistan, is undergoing significant changes. In particular, the credit-module system, which has been widely implemented in recent years, is playing an important role in managing and assessing students' academic activities. One of the main objectives of this system is to provide students with the opportunity to organize their education in a timely, efficient, and independent manner. Through the credit-module system, the educational process is individualized, which expands the opportunities for students to independently learn and develop their knowledge. The subject of geography, being a broad and practical natural science, requires the effective organization of students' independent education and its evaluation based on modern requirements. This system requires assessing students' knowledge not only theoretically but also practically, including fieldwork, cartographic and statistical analysis, and scientific research. Therefore, the issue of how to assess students' independent education in the field of geography based on specific criteria within the credit-module system is one of the current and urgent topics.

## Literature Review

Research related to general approaches for organizing the educational process under the credit-module system is reflected in the studies of scholars such as B. Sh. Usmonov, R. A. Habibullayev, and G. A. Nazarqulov [1]. The organization of independent education has been studied by scientists such as M. L. Boltayeva, S. B. Ibragimova, M. Murodova, N. R. Saitkulova, and K. S. Rakhmonberdiyeva. Specifically, in the field of geography teaching methodology, research has been conducted by scholars such as O. Mo'minov, R. Qurbonniyozov, O. Safarov, X. Nikadamboyeva, F. Khamroyeva, F. Saydamatov, O. Abdimurotov, M. Qo'ldasheva, X. Amanov, F. Rajabov, H. Shodiyev, and D. Abdullayeva [2]. These scientific works provide detailed information on the methodology of teaching geography, ways to effectively organize students' independent education, and modern approaches.

## Research Methodology

Deductive, analytical, comparative, distinguishing, and generalizing the main idea.

## Analysis and Results

Organizing independent education aims to develop students' self-management skills in acquiring knowledge by defining the key stages for the successful implementation of the educational process. The stages of organizing independent education create the necessary conditions for students to consolidate their knowledge, acquire new skills, and achieve effective results in the learning process. The thorough planning of each stage plays a crucial role in ensuring the effectiveness of the educational process and helps in the development of students' independent education skills. The stages of organizing independent education serve as the foundation for the successful implementation of the independent education process, enhancing students' ability to self-study, work independently, and consolidate their knowledge. Each stage of this process is aimed at achieving specific goals, supporting students' independent activities, and helping them acquire new skills. Considering the specifics of the

geography subject and the needs of students, special attention should be given to the following stages for the effective organization of independent education:

1. Goal setting: The first stage of independent education is setting clear and measurable goals for the educational process. In geography, this stage involves determining the scientific knowledge, practical skills, and competencies that students need to acquire. The goals should not only focus on theoretical knowledge but also aim to develop students' skills in analyzing geographical problems, conducting scientific research, and solving problems. During the goal-setting process, necessary resources, scientific sources, and educational materials are identified, and students are provided with opportunities to study geographical areas, apply modern scientific methods, and use information systems effectively to support their independent work. Additionally, considering students' individual needs, interests, and the unique characteristics of the geography subject, their educational process is effectively planned. Successfully organizing this stage helps students enhance their self-improvement skills and establish an effective educational path.

2. Task development: After setting the goals, it is very important to develop specific, goal-oriented tasks to carry out independent education. In geography, these tasks provide students with the opportunity to apply their knowledge in practice, analyze various geographical issues, and learn new scientific methods. The tasks offer students the chance to conduct independent research in various areas of geography, such as analyzing the ecological state of a specific region, studying climate change or the distribution of natural resources, or analyzing geographical data using information technology. These tasks help students deepen their knowledge, consolidate existing knowledge, develop new skills, and learn how to apply geographical methods. Moreover, when developing tasks, the difficulty level for students should be appropriately chosen, meaning the tasks should align with their knowledge and skills, enabling them to successfully carry out their activities. At this stage, students not only acquire new knowledge but also develop skills in independent education and applying the learned knowledge in practice.

3. Organizing the educational process: Effectively organizing the educational process is crucial for the successful implementation of independent education. At this stage, students are provided with the necessary educational materials, scientific resources, technological tools, and methodological approaches. In the study of geography, applying modern methods and technologies enhances the effectiveness of education, as interactive learning materials, digital resources, and information systems help students expand their knowledge. Students are given opportunities to manage their time efficiently and conduct independent work by searching and analyzing scientific sources. Additionally, using the specific methods of geography, such as cartography, GIS (Geographic Information Systems), and climate analysis, helps develop students' research skills. In organizing the educational process, it is also important to support students in self-assessment and in developing effective learning strategies. At this stage, students are provided with the conditions necessary to expand their knowledge, develop new skills, and engage in independent education. This approach to organizing the education process encourages students to engage in scientific research, analyze their knowledge, and apply it in practice.

4. **Monitoring activities:** Monitoring activities play an important role in assessing the students' knowledge acquisition process and achievements in independent education. At this stage, the tasks, research, and practical investigations completed by students are analyzed, and their achievements and shortcomings are identified through evaluation. During the monitoring process, students are encouraged to self-assess, analyze their level of knowledge and results, and work to improve their activities. In geography, this process helps students not only assess their knowledge but also analyze their research and scientific work. The constructive feedback and recommendations from the teacher assist students in correcting their mistakes and improving their work. This process allows students to think independently and apply their knowledge in practice, further developing their scientific and practical skills. Additionally, accurate and effective feedback from the teacher helps students improve their results and succeed in future tasks.

5. **Analyzing results:** As the final stage of the independent education process, the analysis of results involves evaluating students' knowledge, practical skills, and competencies. At this stage, the effectiveness of the educational process is analyzed, and the students' progress is measured. The analysis of results helps assess students' success in the education process and determine their level of knowledge and competencies. Through self-assessment, students set new goals to expand their knowledge and study more deeply. During this process, teachers also have the opportunity to analyze their activities and improve the effectiveness of the education process by developing new methods and approaches. The analysis process also helps students set future educational goals, contributing to the improvement of the education process. At this stage, the conclusions about students' results and their education process create a strong foundation for their future development.

6. **Conclusion:** The final stage of independent education involves evaluating students' acquired knowledge and skills, identifying their achievements, and providing recommendations for further education. At this stage, students analyze the results they have achieved during the independent education process and assess their education. Additionally, they set new goals and prepare for the next educational processes. Concluding the independent education process helps students plan their future educational activities by self-assessing and applying their knowledge. This process strengthens their interest in education, helps them solve new problems, and develops the skills necessary to plan their future education effectively.

### **Conclusion/Recommendations**

The stages of organizing independent education are crucial processes that help students effectively acquire knowledge and provide opportunities for developing new competencies. These stages foster students' ability to self-manage, conduct independent research, and apply knowledge in practice. Properly planning and systematically implementing each stage enhances the effectiveness of the education process. Stages such as setting goals, developing assignments, organizing the education process, monitoring activities, analyzing results, and concluding actively engage students in the education process and increase their interest in education.



The following recommendations are proposed for effectively organizing independent education:

- Creating personalized education pathways: Each student should be provided with education pathways tailored to their personal needs, interests, and current level of knowledge. This includes providing various resources, sources, and education materials, as well as customizing the education process to help students succeed in independent education. Personalized education pathways encourage students to set their own goals and expand their knowledge.

- Creating interactive and collaborative education opportunities: To make independent education more effective, students should be engaged in interactive and collaborative activities. For example, group discussions, exchanging ideas, or conducting joint research enhances knowledge sharing among students and helps develop self-management skills. Using online platforms or digital tools encourages students to share their knowledge with others.

- Providing continuous assessment and self-analysis opportunities: In the independent education process, students need the opportunity to assess their own knowledge and activities. Through continuous assessment and self-analysis, students can improve their education, set new goals, and independently manage the education process. During this process, teachers should support students with constructive feedback and recommendations.

#### References:

- [1] Abdimurotov O.U. "Project method in organizing independent education of future geography teachers under creditmodule system," *American journal of education and learning*. Volume-3, Issue-3, 2024, pp. 151-158.
- [2] Abdimurotov O.U. "The importance of using information technologies in geography education within the conditions of the credit module system," *Proceedings of International Conference on Educational Discoveries and Humanities*, Volume 3, 2022, pp. 262-267.
- [3] Abdimurotov O.U. "Kredit-modul tizimi sharoitida bo'lajak geografiya o'qituvchilarining mustaqil ta'limini tashkil etish shakllari," *"Pedagogika" ilmiy-nazariy va metodik jurnal*. 4-son, 2023, pp. 289-293.
- [4] Abdimurotov O.U. "Geografiya darslarida mustaqil ta'limni tashkil etishda modulli ta'lim texnologiyasidan foydalanish metodikasi," *"Муғаллим ҳам ўзликсиз билимлендируй" илимий-методикалық журнал*. 6/4-сан. 2023, pp. 72-81.
- [5] Abdimurotov O.U. "Kredit-modul tizimi sharoitida bo'lajak geografiya o'qituvchilariga mustaqil ta'limni samarali tashkil etish vositalari," *FAN va JAMIYAT ilmiy-uslubiy jurnal*. №5/2-son. 2024, pp. 56-59.
- [6] Abdimurotov O.U. "Kredit-modul tizimi sharoitida bo'lajak geografiya o'qituvchilariga mustaqil ta'limni tashkil etish dolzarb pedagogik muammo sifatida," *"Ta'lim, fan va innovatsiya" jurnali* 6-son, 2023, pp. 106-110.
- [7] Rajabov F.T., Abdimurotov O.U. "Methods and means of effective organization of independent education in geography under credit-module system," *International Multidisciplinary Research in Academic Science (IMRAS)* Volume. 7, Issue 11, November. 2024, pp. 156-162.
- [8] Rajabov F.T., Abdimurotov O.U. "Geografiya ta'limida mustaqil ta'limni tashkil etish bo'yicha xalqaro tajribalar," *"Geografiya - nazariyadan amaliyotga" mavzusidagi xalqaro ilmiy-amaliy konferensiya materiallari to'plami*. Qo'qon. 25-noyabr, 2024, pp. 393-398.
- [9] Murodova M. "Kredit-modul tizimida mustaqil ta'lim," O'quv-uslubiy qo'llanma. Toshkent: "Fan ziyosi" nashriyoti, 2023.



- [10] Nazarqulova G.A. “Kredit-modul tizimida bo`lajak boshlang`ich sinf o`qituvchilarining mustaqil ta`lim olish imkoniyatlarini takomillashtirish,” *Dissertatsiya*. – T.: 2023, p. 152.
- [11] Raxmonberdiyeva K.S. “Talabalarga chet tili o`qitishda mustaqil ta`limni tashkil etish metodikasini takomillashtirish texnologiyalari (nofilologik yo`nalishlar misolida),” *Dissertatsiya*. – T.: 2023, p. 135.
- [12] Ibragimova S.B. “Mustaqil ta`lim jarayonida talabalarning xorijiy tilni o`zlashtirish ko`nikmasini rivojlantirish texnologiyasi (kredit-modul tizimidagi iqtisodiyot yo`nalishi talabalari misolida),” *Dissertatsiya*. – T.: 2024. –148 b.

UDC: 37, 377, 796.01

## ETHICAL COMPETENCES AND THEIR PEDAGOGICAL ANALYSIS

**Rakhmonov Sunnatillo Mavlonovich**

*Professor, Uzbekistan State World*

*Languages University*

[sunnat.rahmonov@inbox.ru](mailto:sunnat.rahmonov@inbox.ru)

**Annotatsiya.** Mazkur maqolada axloqiy kompetensiyalar va uning pedagogik tahlili aks ettirilgan. Kompetensiya tushunchasi muayyan sohada faoliyat olib boradigan mutaxassisning samarali, nazariy va amaliy tayyorgarligiga qo`yiladigan talablardir. Axloqiy kompetensiya mezonlarining muhim tarkibiy qismlaridan biri vatanparvarlikdir. Vatanparvarlik so`zining negizini ona Vatanga bo`lgan muhabbat tashkil etadi.

**Kalit so`zlar:** kompetensiya, kompetentlik, tayanch kompetensiyalar, kasbiy kompetenyesiya.

**Аннотация:** В данной статье отражены моральные компетенции и их педагогический анализ. Понятие компетентности – это требования к эффективной, теоретической и практической подготовке специалиста, работающего в определенной области. Одной из важных составляющих критериев моральной компетентности является патриотизм. В основе слова патриотизм лежит любовь к Родине.

**Ключевые слова:** компетентность, компетентность, базовые компетенции, профессиональная компетентность.

**Abstract:** This article reflects moral competences and its pedagogical analysis. The concept of competence is the requirements for the effective, theoretical and practical training of a specialist working in a certain field. One of the important components of the criteria of moral competence is patriotism. The basis of the word patriotism is love for the Motherland.

**Keywords:** competence, competence, basic competences, professional competence.

### Introduction

Today's rapid development once again demonstrates that education cannot be separated from upbringing, and upbringing from education. Only if education and

upbringing are organized on a harmonious, continuous basis can we cultivate young cadres who have mature moral qualities, are highly spiritually mature, and at the same time are knowledgeable, intelligent, spiritually and physically healthy, have a broad worldview, are patriotic, and can meet the requirements of the time. In this, the formation of moral competencies in students plays an important role.

The term competence is derived from the Latin word “competere”, which means “to achieve, to be in accordance with, to be suitable”, and is a type of ability that embodies a set of certain knowledge, skills, and abilities acquired by people [1]. Competence in a broad sense is the ability to apply existing knowledge and skills in practical experience in complex situations. Therefore, competence can also be called the ability to apply acquired knowledge, skills, and abilities in practice.

## Literature Review

The term competence began to be widely used in scientific research in the 60s-70s of the 20th century. More precisely, in linguistic research, the term “competence” was first noted as a set of knowledge, skills, and abilities aimed at activity in the process of using a particular language [2].

Another study defines competence as “a specific area of activity in which an individual demonstrates a highly developed strategy for success. This strategy is a set of strategies, skills, and practical knowledge that have emerged on the basis of existing knowledge and regular self-improvement. Therefore, competence is the ability to function effectively through the development of strategies for success [3].

The concept of “competence” is a concept that emerged from pedagogical research and is understood as how a person behaves in unconventional situations, engages in free communication, and has a new style and plan of action in interpersonal relationships.

The introduction of a competency-based approach in the education system of our country, particularly in higher education, has led to the improvement of the requirements of state educational standards, as well as the improvement of curricula at all stages of the education system.

The concept of competence is a scientific term for the requirements for effective, theoretical, and practical training of a specialist working in a particular field. In particular, the term competence is used in relation to scientific or professional training for effective work in the field of pedagogy. For example, the formation of moral competencies in students leads to their ability to apply the acquired knowledge, skills, and qualifications in their personal, professional, and social activities. As a result, students develop such characteristics as initiative, independent thinking, active citizenship, rational use of modern technologies, independent choice of profession, and choice of a healthy lifestyle.

Pedagogical competencies formed in the modern educational process can be classified into the following groups:

- professional competence;
- special competence;
- spiritual and moral competence;
- basic competence, etc.

Professional competence – is the acquisition of knowledge, skills and competencies necessary for the implementation of professional activities by a particular specialist and the ability to apply them in practice. Professional competence is a process that involves not the acquisition of separate knowledge and skills, but the mastery of integrative knowledge and actions in each area. Also, professional competence is the ability to constantly enrich one's knowledge in a particular specialty, to learn, process and effectively apply new information in one's activities.

Special competence– is formed on the basis of professional competence, excellent organization of professional and pedagogical activities, rational solution of professional and pedagogical tasks, objective assessment of the results of the activities of pupils or students, consistent development of knowledge, skills and qualifications. On the basis of special competence, such qualities as psychological, methodological, informational, creative, innovative and communicative competence are also formed.

Spiritual and moral competence -It is the ability of students to reflect their high level of preparedness, competence, cultural and spiritual-moral level, and universal and national values in their activities. Universal cultural competence is a process that helps students comply with the rules of etiquette established in society, develop themselves, manage their emotions, and improve their ability to acquire knowledge, study, and learn.

Another important component of the criteria for moral competence is fairness. Fairness is a process that mainly expresses the positive, humane impact of a person on a particular society or state based on legal and moral norms. Fairness is closely related to the concept of justice, and the legal and moral well-being of individuals or social groups in society is ensured and brought to a single standard precisely on the basis of justice.

As moral competencies are formed in students, they lead to the formation of an independent worldview, the unity of word and deed, and the formation of qualities of concern not only for personal but also for the benefit of society. The specific moral thinking, moral virtue, moral attitude, and moral actions formed in students are formed as a set of moral competencies, which serve their striving for perfection, that is, to become a perfect person.

## **Analysis and Results**

In today's developing society, the issue of paying special attention to the upbringing of the younger generation at all stages of the education system is gaining special importance. Therefore, under the slogan of praising the Motherland, it is becoming one of the important tasks of professional educators to deeply convey to modern youth that there is no greater wealth for a person than the Motherland, that the Motherland is the hearth of culture, spirituality, literature, art, science in which a person lives, and that, as stated in the hadiths, "Loving the Motherland is part of faith." After all, the Motherland is these vast fields, the children of this land, their life, lifestyle, faith, customs and millennial traditions and customs, monuments built by the hands of that people, the rich material and spiritual heritage of their ancestors, language, history and state symbols. Therefore, one of the spiritual and moral requirements of today's modern youth is to provide them with deep theoretical and practical knowledge, as well

as to form important professional qualifications and skills, to teach them to react correctly to all events in social life, and to educate them in the spirit of love for the Motherland, to inherit the invaluable spiritual heritage created by their ancestors, to preserve and enrich it, and to strive to lead their country to modern development. After all, a generation with a well-formed spiritual and moral outlook understands the qualities of spiritual and moral knowledge, spiritual and moral thinking, spiritual and moral feelings, and spiritual and moral perception, while forming spiritual perception and moral will in itself, and improving its personal life with its knowledge and skills.

Social competence is the ability to act in a society, taking into account the views of other people, while socio-cultural competence is the process of acting in accordance with one's own and others' cultures, using universal etiquette, cultural identity, and legal knowledge [4].

Spiritual and moral competencies are one of the most important areas of competence, through which qualities such as loyalty to the Motherland, entrepreneurship, willpower, ideological immunity, kindness, responsibility, tolerance, legal culture, innovative thinking, and hard work are formed.

In today's developed society, the increasing activity of various gadgets and social networks leads to the lack of formation or insufficient development of such mobility characteristics as setting ambitious goals, striving for study and research, as well as willpower, perseverance and diligence in some young people, which also harms the quality of education. As a result, differences are manifested in the formation of loyalty to the Motherland, duty and responsibility, initiative qualities, and moral upbringing among today's young people. This creates a number of problems in finding their place in life for today's young people who are entering an independent life. Therefore, today, we should pay special attention to the formation of spiritual and moral educational competencies in educating young people.

One of the important components of the criteria for moral competence is patriotism. The basis of the word patriotism is love for the Motherland. Etymologically, the word homeland is derived from the Arabic language and means "the place where the umbilical cord blood was shed, the land". The homeland is as unique and sacred as the mother is. A sense of duty and responsibility to the homeland is a characteristic of every mature person. Love for the homeland is inherent in patriotism manifestation will be [5].

Core competencies include communicative competence, information literacy, self-development competence, socially active citizenship competence, and national and general cultural competencies. In addition, subject-specific competencies have been developed for all subjects.

Communicative competence based on core competencies is of particular importance, and it is understood that a person must perfectly master a specific language in order to communicate in society, be able to use it effectively in communication, be able to clearly and understandably express his or her thoughts orally and in writing, be able to logically direct and answer questions, adhere to a culture of communication in communication, have his or her own position, be able to control himself in various conflict situations, and be able to make necessary, constructive decisions in resolving problems and disagreements.



The competence of working with information based on core competencies includes the ability to rationally use existing information sources, more precisely, social networks, Internet resources, mass media, telephone, computer, and e-mail. After all, in today's era of information attacks, it is a complex analytical process for students to search for the necessary information from media, sort it, process it, analyze it, and use it in a culture that ensures their own safety.

The competence of self-development as a person based on core competencies is understood as the ability of a person to constantly strive for self-development, to strive for both physical and spiritual and intellectual perfection, to systematically develop their knowledge and experience, to be able to control themselves, and to embody truly human qualities such as honesty and integrity.

Socially active citizenship competence based on core competencies is understood as the formation of abilities in students that form a sense of involvement in events, phenomena, and socio-political processes taking place in society, that enable them to know and adhere to their active civic position and duty, that enable them to have a universal and legal culture in labor and civic relations, and that enable them to serve the interests of society and their family.

Being loyal to the homeland, being equally kind to all people, remaining faithful to universal and national values, following a healthy lifestyle, respecting universal values, customs, rituals, and national and cultural traditions, being kind and generous to others, respecting everyone regardless of religious beliefs, national and ethnic origin, preserving one's historical, spiritual, and cultural heritage, and most importantly, strictly adhering to the norms of etiquette established in society are components of moral competence. Indeed, as research has emphasized, in today's era, when the interaction of peoples, languages, and cultures is unprecedentedly widespread, ensuring tolerance towards other cultures, arousing interest and respect for them, and finding positive solutions to emerging problems are among the most fundamental universal principles [6].

## **Conclusion**

In conclusion, any subject or education aimed at the formation of competencies in higher education institutions becomes education that guides students to apply the acquired knowledge, skills, and qualifications in their activities. As a result, in addition to all the necessary competencies listed above, students also develop specific competencies based on the content of a particular subject in the process of mastering this subject. That is why, in order to ensure the consistency of the content of education in our country, basic competencies are distributed and instilled at all stages of the education system based on the content of each subject.

Today's development in the education system requires, first of all, fundamental changes in the professional potential and thinking of the teacher in order to implement innovative ideas, in which the teacher, along with the knowledge contained in modern textbooks, becomes a supplier of knowledge about moral competence to students. Because only a teacher with perfect moral education can prepare a person with socio-moral competence.

## **Reference:**



- [1] Rakhmonov S. "Pedagogical and educational significance of the scientific heritage of Jalaluddin Rumi (on the example of Masnavii and spiritual)," Samarkand: SamDCHTI, 2024, p. 123.
- [2] Galskova N.D. "Intercultural learning: the problem of goals and content of teaching foreign languages," *Foreign languages at school*. № 1, M.: 2004.
- [3] Milrud R.P. "Scientific dialogue," № 2 (14): *Pedagogy*. M.: – 2013.
- [4] Ilyasov D.F. "Formation of professional competence of future teachers in the context of creative activity of students," Collection of scientific papers and conference materials - Formation of professional competence of primary school teachers. Samara: GP "Perspektiva"; OOO "Ofort," - Part 2, 2003.
- [5] "Qomus info.," Ensiklopediya. <https://qomus.info/encyclopedia/cat-v/vatan-uz/>
- [6] Khutorskoy A.V. "Technology of designing key and subject competencies," *Internet magazine "Eidos"*. December 12, 2005.

UDC 37, 37.01/.09, 37.04

## IN HIGHER EDUCATION NEXT GENERATION TEXTBOOKS AND THEIR REQUIREMENTS

**Norboyev Zafar Abdumuminovich**

*Head of the department, Uzbekistan State*

*World Languages University*

[z.norboyev88@gmail.com](mailto:z.norboyev88@gmail.com)

**Annotasiya.** Mazkur maqolada oliy ta'lim muassasalarida yangi avlod darsliklari va ularga qo'yilgan talablar yoritilgan. Yangi avlod darsliklarining sifati talabalarda kompetentlikni shakllantirishga qaratilgan bo'lib u darslik mazmuni bilan baholanadi. Yangi avlod darsliklarining oldiga qo'yiladigan eng asosiy talablardan biri uning strukturasi va mazmunini muayyan fanning namunaviy dasturi mavzulariga to'liq moslashtirishdir.

**Kalit so'zlar:** yangi avlod darsliklari, innovatsion ta'lim, interaktiv yondashuv, kreativlik, kompetensiya.

**Аннотация.** В данной статье описаны учебники нового поколения и требования к ним в высших учебных заведениях. Качество учебников нового поколения направлено на формирование компетентности учащихся и оценивается содержанием учебника. Одним из основных требований к учебникам нового поколения является полная адаптация его структуры и содержания к темам типовой программы конкретного предмета.

**Ключевые слова:** учебники нового поколения, инновационное образование, интерактивный подход, креативность, компетентность.

**Abstract.** This article discusses new generation textbooks and the requirements for them in higher education institutions. The quality of new generation textbooks is aimed at building competence in students and is assessed by the content of the textbook. One of the most important requirements for new generation textbooks is

to fully align their structure and content with the topics of the standard curriculum for a particular subject.

**Keywords:** *next generation textbooks, innovative education, interactive approach, creativity, competence.*

## **Introduction**

Since special attention is paid to the in-depth study of foreign languages in our country, a number of reforms are also being implemented to create a new generation of textbooks for teaching languages. As our president noted, “New textbooks should be prepared so perfectly that we will not have to go back to this later. Today’s education will speak about us in forty years” [1]. The creation of new generation textbooks in the higher education system should include aspects such as the formation of a common approach to the study of science, adherence to sequence in the content of educational materials, a common approach in determining methodological directions, the selection of illustrative materials, and commonality in the style of textbooks.

## **Literature Review**

New generation textbooks for undergraduate programs in the higher education system should be created based on the following requirements:

- textbook topics, content, and texts should not repeat each other;
- the working curriculum and subject programs are structured in accordance with the content; taking into account the age and psychophysiological characteristics of students, the topics are focused on developing students' creative abilities, and they are interested in independent learning;
- educational materials should be understandable for students;
- using technologies that encourage students to think and find solutions to problems, along with generally accepted ideas in the textbook;
- to focus the content of educational materials on specific practical skills to form and develop the necessary competencies in students;
- providing educational literature with problem questions, assignments, exercises, and projects of a professional nature and designed for independent work;
- creating learning situations that require active practical work and increasing the effectiveness of learning materials;
- Students should be provided with references and citations that can be read in detail on the theoretical presentation of each topic [2].

The quality of new generation textbooks is aimed at forming competence in students and is assessed by the content of the textbook, the motivation of students, mastery of knowledge, skills and qualifications, and the formation of competencies. Also, when creating new generation textbooks, the level of complexity of the topic, its theoretical or practical features, the role and importance of the topic in the student's future activities, and the importance of independent learning in mastering the topic are taken into account. In a word, new generation textbooks should direct students not only to in-depth study of a particular language, but also to scientific research and conduct research on topical topics in their specialty.

The concept of new generation textbooks is applied to publications that modernize education and are prepared in accordance with state educational standards. The main



value of educational literature created for higher education institutions is not in the completeness of its content or the detail of its text but in how the student can work with this resource [3]. Therefore, when developing new educational literature, it should be maximally equipped with technologies, developed to the extent that it encourages students to engage in two-way communication, and reflect the content of training students in a specific direction or specialty in traditional and distance forms of education.

### **Research Methodology**

This study employs a qualitative research approach to examine the development of new-generation textbooks for foreign language education in Uzbekistan, with a focus on Arabic language instruction.

### **Analysis and Results**

The main educational reform of today's New Uzbekistan strategy As the issue of updating and developing the educational and methodological bases of educational institutions in the country is gaining urgent importance, conducting new research on the increase in new generation textbooks and covering the education system with new generation textbooks is one of the issues that has risen to the level of state policy. After all, the theory of creating new generation textbooks has a positive impact on the dynamics of the development of the education sector to a certain extent, identifying achievements and shortcomings at all stages of development, as well as creating opportunities for assessment based on criteria.

If we pay attention to the composition of the new educational literature, the composition of educational literature consists of textbooks and study guides, methodological instructions, and lecture texts [4]. When creating new educational literature, first of all, it is necessary to adapt it to a specific academic discipline, that is, if the new educational literature is intended for the subject of the Arabic language, then adapt it to the Arabic language, and pay attention to the analysis of lectures, seminars and practical classes containing textbooks based on the teaching of the Arabic language. Lectures on teaching the Arabic language summarize theoretical aspects such as the theory of the language, grammar by language levels, lexicology, stylistics, comparative typology of the Arabic language and the Uzbek language. By effectively teaching students the theoretical aspects of the Arabic language, their Arabic language skills are developed. Seminar sessions focus on reinforcing the topics covered in lectures, while practical sessions focus on developing students' Arabic language skills.

In accordance with modern requirements, the educational and methodological support of the subject, along with traditional textbooks and study guides, should also consist of digital educational resources or only electronic textbooks. The Resolution of the Cabinet of Ministers of the Republic of Uzbekistan № 816 "On providing higher educational institutions with educational literature", adopted on October 10, 2018, reflects the general requirements for all educational literature, and also defines the forms and types of educational literature, the procedure for their creation and publication, and the principles of creating electronic educational literature [5].

One of the main requirements for new-generation textbooks is the full compliance of their structure and content with the topics of the standard program of a particular

subject. In particular, in higher educational institutions of the philological direction, the technology of creating new-generation textbooks using the CEFR criteria creates a certain difference from textbooks in terms of both volume and correspondence of topics in the subject program and the work program in the language section. That is, if this textbook specializes in the Arabic language, the degree of correspondence of the topics specified in the subject program and the work program in the textbook is evaluated in percentages, which determines the teacher's skills in creating textbooks.

## Conclusion

Today, textbooks and study guides prepared by professors and teachers are usually discussed at department, faculty, and university councils and, after receiving positive conclusions, are sent to leading higher education institutions for final conclusions in accordance with their field and specialty, with the recommendation of the coordinating council. After the professors and teachers with scientific potential at the base higher education institutions review the textbooks and study guides based on certain requirements, if this textbook or study guide meets the established requirements, it is recommended for publication by giving a positive conclusion. It should also be noted that textbooks that do not meet certain requirements are not recommended by the coordinating council and are not published. Therefore, the process of creating a textbook is a complex one, and in the preparation of new educational literature being created today, in particular in higher educational institutions of the philological direction, it is advisable that the technology for creating new generation textbooks (in the case of Arabic) through SEFR criteria be in line with the above-mentioned criteria, and that new generation textbooks used in teaching Arabic as a second foreign language be created based on international experience for use in classes.

## Reference:

- [1] "The cornerstone of development is science and education," *President Shavkat Mirziyoyev opened an exhibition of modern textbooks on the theme "Improving the quality of education is the only correct path to the development of a new Uzbekistan!"* on December 29 at the International Congress Center. 29.12.2022. [https://uza.uz/uz/posts/taraqqiyotning-tamal-toshi-ilm-fan-va-talim-tarbiyada\\_440242](https://uza.uz/uz/posts/taraqqiyotning-tamal-toshi-ilm-fan-va-talim-tarbiyada_440242)
- [2] Tursunov K., Normamatova N. "Modern methodological requirements for the structure of the textbook," *Public Education magazine*, issue 2, 2015.
- [3] Djuraev R.Kh., Nematov Sh.Kh. "Historical development of textbooks and their place in the educational process today," T.: *Sano-Standard*, 2010.
- [4] Osmolovskaya I.M. "New generation textbooks: search for didactic solutions," *Domestic and foreign pedagogy*, № 4(19), 2014.
- [5] "On providing higher educational institutions with educational literature," Resolution № 816 of the Cabinet of Ministers of the Republic of Uzbekistan, 11.10.2018.