



# ACTUAL PROBLEMS OF MODERN SCIENCE, EDUCATION AND TRAINING

**KHOREZMSCIENCE.UZ**





## CONTENTS

<b>Section 1. ACTUAL PROBLEMS OF MATHEMATICS, PHYSICS AND MECHANICS.....</b>	<b>4</b>
ADIZOVA AZIZA JO'RAQULOVNA, MAVLANOV TULKIN /// THE METHOD OF CALCULATION AND ANALYSIS OF THE OBTAINED RESULTS IS BASED ON NUMERICAL MODELING OF THE DEFORMATION PROCESSES OF TEXTILE THREADS.....	4
JURAKULOV TOLIB, ISROILOVA LOLA, SADULLAYEVA MAFTUNA /// INNOVATIVE APPROACH TO MATHEMATICAL MODELING OF LEARNING PROCESSES AS AN OBJECT OF DIGITAL TECHNOLOGY (using advanced training as an example).....	10
ALIJON RAZZOKOV, MAXBUBA SOTIMOVA /// PECULIARITIES OF $(\text{Ge}_2)_{0,02}(\text{ZnSe})_{0,03}(\text{GaAs})_{0,95}$ SOLID SOLUTIONS PREPARATION AND THEIR PHOTOELECTRIC PROPERTIES.....	15
BEKCHANOV SHUKURLA KURBANBAYEVICH /// AUTOMATIC SUMMARIZATION OF TEXT IN UZBEK LANGUAGE USING KEYWORDS.....	20
AMIN SAIDOV, SHUKRULLO USMONOV, SHAHZOD MASHARIPOV, UMIDA ASATOVA, DADAJON SAPAROV /// FIRST PRINCIPLE STUDIES ON STRUCTURAL AND ELECTRONIC PROPERTIES OF GALLIUM PHOSPHIDE AND SOLID SOLUTION $(\text{Si}_2)_x(\text{GaP})_{1-x}$ .....	26
<b>Section 2. MODERN PROBLEMS OF TECHNICAL SCIENCES.....</b>	<b>33</b>
MATCHANOV RAFIK DOSCHANOVICH, YULDASHEV AZAMAT ISMAILOVICH /// CALCULATION OF THE MAIN DESIGN PARAMETERS OF A FAN SPRAYER WITH A DOUBLE NOZZLE.....	33
KHOLIQOV MUKHRIDDIN MARDIKULOVICH, DJURAEV KHAYRULLO FAYZIYEVICH /// THE EFFECTIVENESS OF TECHNOLOGY FOR DRYING FRUITS AND VEGETABLES PASTILLA.....	40
NARZIEV SHOVKIDDIN MURTOZAEVICH, SULAYMANOV SUNNATILLA /// FULFILLMENT OF THE REQUIREMENTS OF LEGAL-NORMAL-TECHNICAL DOCUMENTS OF LABOR PROTECTION MANAGEMENT IN PHYSICAL EDUCATION AND SPORTS.....	45
<b>Section 3. ACTUAL PROBLEMS OF HISTORY, PHILOSOPHY AND SOCIOLOGY.....</b>	<b>51</b>
KASIMOV ABDUMAVLON /// ANALYSIS OF THE RESULTS OF SOCIOLOGICAL RESEARCH ON ISSUES OF IMPLEMENTING DEPUTY CONTROL OVER THE EXECUTION OF THE LOCAL BUDGET.....	51



<b>ZIYAEVA KHALIDA AMONKUL KIZI /// UNIVERSAL METHODS OF CLASSIFICATION OF VIOLENCE AGAINST PEOPLE WITH DISABILITIES.....</b>	<b>56</b>
<b>TAGIEVA GULSUM GAFUROVNA /// THEORICAL APPROACHES OF THE SOCIAL SUPPLY SYSTEM TO THE EASTERN SOCIAL THOUGHT.....</b>	<b>61</b>
<b>Section 4. ACTUAL PROBLEMS IN MODERN ART AND ARCHITECTURE..</b>	<b>70</b>
<b>DADAEV AKHMATJON SHAKARIMOVICH /// DARVESH ALI CHANGI'S OPINIONS ABOUT COMPOSERS.....</b>	<b>70</b>
<b>KHUDAYBERGANOV SAMANDAR KUZIEVICH /// FROM THE HISTORY OF KHOREZM MAQAMS.....</b>	<b>74</b>
<b>Section 5. MODERN PROBLEMS OF TOURISM AND ECONOMICS.....</b>	<b>79</b>
<b>MOHIGUL ASRONOVA MUSABOYEVNA /// GENERAL AND SPECIAL CHARACTERISTICS OF ECONOMIC DISCOURSE.....</b>	<b>79</b>
<b>OLIMOV OLIMBOY DJALALADDIN UGLI /// CHINA AND UZBEKISTAN: A NEW ERA OF ECONOMIC COOPERATION AND INVESTMENT.....</b>	<b>83</b>
<b>Section 6. MODERN PROBLEMS OF PEDAGOGY AND PSYCHOLOGY.....</b>	<b>91</b>
<b>IBRAGIMOVA NAZOKAT MUXTAROVNA /// DEVELOPMENT OF SOCIOLINGUISTIC COMPETENCE IN PEDAGOGICAL PRACTICE.....</b>	<b>91</b>
<b>Section 7. ACTUAL PROBLEMS OF NATURAL SCIENCES.....</b>	<b>97</b>
<b>AMINOV BEKHZOD BAKHRAM UGLI /// IMPACT OF CLIMATE CHANGE ON LANDSCAPES OF KHOREZM REGION.....</b>	<b>97</b>
<b>NIYAZMETOV AZAMAT RAHMATJONOVICH /// BROMATION REACTIONS OF 2-ARYLQUINOLINE DUBAMINE.....</b>	<b>101</b>





UDC: 677, 531, 531-1/-9, 531.3, 534.1

**THE METHOD OF CALCULATION AND ANALYSIS OF THE OBTAINED RESULTS IS BASED ON NUMERICAL MODELING OF THE DEFORMATION PROCESSES OF TEXTILE THREADS**

**Adizova Aziza Jo‘raqulovna**

*Senior Lecturer, Department of Fundamentals of Mechanics, Bukhara Engineering Technological Institute*  
[aziza\\_adizova@mail.ru](mailto:aziza_adizova@mail.ru)

**Mavlanov Tulkin**

*Doctor of Technical Sciences, Professor, Department Mechanics and Computer Modeling, Tashkent Institute of Irrigation and Agricultural Mechanization Engineering, National Research University*

**Annotatsiya.** Tajriba natijalarni hisoblash va tahlil qilish usullarini yaratish zamonaviy kompyuterlarda deformatsiya jarayonlarini raqamli modellashtirish uchun dasturiy ta‘minot to‘plamining samaradorligini sezilarli darajada oshiradi. Ushbu ishda to‘qimachilik iplarining deformatsiya jarayonlarini raqamli modellashtirish asosida olingan natijalarni hisoblash va tahlil qilish usuli taklif etiladi. Muammoni shakllantirishda qovushqoq-elastiklikning matematik nazariyasi va dinamikaning variatsion prinsiplaridan foydalanilgan.

**Kalit so‘zlar:** munosabat, deformatsiya, deformatsiya, tizim, ob‘ekt, damping, tezkor-elastik, algoritm, funktsiya, elastiklik, erkinlik darajasi

**Аннотация.** Создание экспериментальных методов расчета и анализа результатов значительно повышает эффективность программного комплекса для численного моделирования деформационных процессов на современных компьютерах. В данной работе предложен метод расчета и анализа результатов, полученных на основе цифрового моделирования процессов деформации текстильных нитей. При постановке задачи использовались математическая теория вязкоупругости и вариационные принципы динамики.

**Ключевые слова:** соотношение, деформация, деформация, система, объект, затухание, упруго-проявленный, алгоритм, функция, упругость, степень свободы

**Abstract.** The creation of experimental methods for calculating and analyzing the results significantly increases the efficiency of the software package for numerical simulation of deformation processes on modern computers. In this paper, a method for calculating and analyzing the results obtained on the basis of digital modeling of the deformation processes of textile yarns is proposed. The mathematical theory

of viscoelasticity and variational principles of dynamics were used in the formulation of the problem.

**Keywords:** *relationship, strain, deformation, system, object, damping, prompt-elastic, algorithm, function, elasticity, degree of freedom*

## Introduction

It is evident that obtaining accurate analytical solutions to dynamic problems of viscoelasticity of textile threads is impossible, and therefore the only possibility of engineering implementation is to build numerical and numerical-analytical calculation algorithms with subsequent computer-based simulation [1].

The creation of methods for calculating and analyzing the results obtained significantly increases the efficiency of the software package for numerical simulation of deformation processes on modern computers.

The device of the mathematical theory of viscoelasticity and variation principles of dynamics are involved in the formulation of the problem. The integral terms in ancestral relations are small compared to the prompt-elastic terms, which in particular leads to the following physical relations [2]:

$$\begin{aligned}\sigma_{ij} &= \lambda_n \varepsilon_{kk} \delta_{ij} + 2\tilde{\mu}_n \varepsilon_{ij}, \quad (n = 1, 2 \dots, s); \\ \tilde{\lambda}_n &= \lambda_n [1 - \Gamma_{n\mu}^c(\omega_R) - i\Gamma_{n\mu}^s(\omega_R)]; \\ \tilde{\mu}_n &= \mu_n [1 - \Gamma_{n\mu}^c(\omega_R) - i\Gamma_{n\mu}^s(\omega_R)]; \quad \tilde{\omega} = \omega_R + i\omega_1,\end{aligned}$$

The most general linear theory, which most fully reflects almost all the features of the quasi-static and dynamic behavior of viscoelastic materials, is the Boltzmann-Voltaire theory, according to which the relationship between stresses and strains has the form:

$$\sigma(t) = E[\varepsilon(t) - \int_0^t R(t-\tau)\varepsilon(\tau)d\tau] \quad (1)$$

where  $\sigma$  is the stress,  $\varepsilon$  is the strain,  $t$  is observation time,  $0 \leq \tau \leq t$  is intermediate moment,  $E$  is Young's prompt modulus,  $R$  is memory function or relaxation kernel.

The type of the core  $R$  largely separates both the behavior of the material model [3] and the possibility of using certain methods for solving problems for materials modeled using relation (1). If the function  $R$  has the form of an exponent or a sum of exponents, then relations (1) are reduced to differential relations, the order of which is equal to the number of exponents in the indicated sum. The most adequate description of the behavior of viscoelastic materials is weakly singular heredities, of which we note the kernel of Bronsky A.P. [4]:

$$\sigma(t - \tau) = \frac{\alpha \lambda e^{-(t-\tau)\alpha}}{(t-\tau)(t-\tau)^{1-\alpha}}, \quad 0 < \alpha < 1$$

Power kernel

$$K(t - \tau) = \frac{\beta}{(\alpha)(t-\tau)^{1-\alpha}}, \quad 0 < \alpha < 1$$

## Research Methodology

In order to solve the problems posed in this work, the kernel of Koltunov M.A. and Rzhantsyn A.P. has been used:

$$\tau(t - \tau) = \frac{Ae^{-\beta(t-\tau)}}{(t-\tau)^{1\alpha}} \quad (2)$$

which, on the one hand, very satisfactorily reflects both the quasi-static and dynamic behavior of materials, on the other hand, is most convenient when carrying out quasi-static and dynamic calculations and determining mechanical vibrations.

For a material with a finite long-term modulus of elasticity [4], a four parametric kernel is used with the feature

$$K(t - \tau) = \frac{Ae^{-\beta(t-\tau)}}{T^q(t-\tau)^p}, \quad (3)$$

which will be uses in solving problems of the dynamics of viscoelastic threads.

The corresponding relaxation kernel has the form

$$R(t - \tau) = \left(\frac{e^{-\beta(t-\tau)}}{t - \tau}\right) \sum_{j=1}^{\infty} (-1)^{j+1} \left[\frac{A\Gamma(q)^j \left(\frac{t-\tau}{T}\right)^{qj}}{A\Gamma(jq)}\right]$$

For a constant load, we have

$$\varepsilon(t) = \left(\frac{\sigma}{E}\right) \left(1 + \left(\frac{A}{T^q}\right) \int_0^t \frac{e^{-\beta(t-\tau)}}{(t-\tau)^p d\tau}\right) = \left(\frac{\sigma}{E}\right) \left(1 + \frac{A\gamma(\beta t, p)}{(T\beta)^q}\right) \quad (4)$$

where  $\gamma(\beta t, p)$  is an incomplete gamma function. At  $t \rightarrow \infty$

$$\varepsilon(\infty) = \left(\frac{\sigma}{E}\right) \left[1 + \frac{A\Gamma(q)}{(T\beta)^q}\right]$$

The problem of vibrations of viscoelastic systems is reduced to a system of integral-differential equations (differential in coordinates and integral-differential in time). The system of equations contains partial derivatives in the case of systems with distributed parameters and ordinary derivatives in the case of systems with a finite number of degrees of freedom. Statements of problems of the theory of viscoelasticity as quasi-static are presented with exhaustive completeness in monographs [1]. Dynamic problems with an infinite number of degrees of freedom with the help of any approximate method (Bubnov-Galerkin, Ritz, finite elements) can be reduced to a system of a finite number of differential or integral-differential equations in time [5].

From the point of view of mechanics, this means replacing a system with an infinite number of degrees of freedom by a system with lumped parameters or, at the same time, imposing an infinite set of additional constraints on the original system [6]. In this way, the vast majority of problems in the nonlinear and linear theory of viscoelasticity have been solved. The main difficulty that arises along this path is the choice of the basis coordinate functions in which the desired solution is expanded.

These functions are quite simple in the case of bodies with a simple shape.

It is for such objects that the vast majority of solutions known of dynamic viscoelasticity problems have been obtained [7]. In the case of a body of a more or less complex shape, the choice of the system of basis coordinate functions of the projection method, which reduces the original system to a system with a finite number of degrees of freedom, is a difficult problem [8, 9].

## Analysis and Results

As an example, let us consider the longitudinal oscillations and the tension of the threads in the process of beating on a loom. We consider that one end of the thread is fixed on a rock, and a beating is made on the other end. Let the end of the main thread

at the edge be connected with the reed, so the speed of this end during the beating is equal to the speed of the reed, and this speed can be considered linear,  $v = v_0 - \beta t$ , where  $\beta = v_0 / t_{i0}$ ;  $t_{i0}$  is beating time. In contrast to, we will consider the thread to be viscoelastic [10, 11]. Then the integral-differential equation of motion of the thread will be written as follows:

$$a^2 \frac{\partial^2 u}{\partial x^2} = \frac{\partial^2 u}{\partial t^2} + a^2 \int_0^t R(t-\tau) \frac{\partial^2 u}{\partial x^2} d\tau \quad (5)$$

Boundary and initial conditions must be added to this system of equations:

$$u(0,t) = 0, \quad u(l,t) = v_0 t - 0.5 \beta t^2, \quad u(x,0) = 0, \quad \dot{u}(x,0) = 0 \quad \text{at } 0 \leq x < l \quad \text{and} \quad \dot{u}(x,0) = v_0 \quad \text{at } x = l.$$

Therefore, the mathematical model of the task has been built, and now we need to write a program that implements it.

According to, the solution to equation (5) for all  $t \geq 0$  will be close to the solution

$$u(x,t) = (x/l)(v_0 t - 0.5 \beta t^2) + (b/6la^2)x(l^2 - x^2) + \sum_{n=1}^{\infty} \exp(-0.5 \varepsilon Gc(t) \lambda(n)t) ((-1)^n (2bl^2 (an\pi)^{-3} \cos(1 - 0.5 \varepsilon Gc(t) \lambda(n)t) - (-1)^n 2v_0 l (a^{-1} (n\pi)^{-2} \sin(1 - 0.5 \varepsilon Gc(t) \lambda(n)t) \sin \lambda(n) x a^{-1} \quad (6)$$

where

$$\lambda(n) = \pi n a l^{-1}; \quad Gc(t) = \int_0^t A \exp(-\beta(t-s)) ((t-s)^{\alpha-1}) \cos \lambda(n)s \, ds;$$

$$Gs(t) = \int_0^t A \exp(-\beta(t-s)) ((t-s)^{\alpha-1}) \sin \lambda(n)s \, ds.$$

As can be seen from the function  $u(x,t)$ , it exponentially decreases in time and characterizes damped oscillations. Thus, the process of propagation of a perturbation in a thread consists of the motion of the particles of the thread, which leads to an increase in deformations and a damping of the amplitude of its free oscillations.

The program and calculation results are shown in Figures 1-5, respectively. In this case, the “Mathcad” software package has been used.

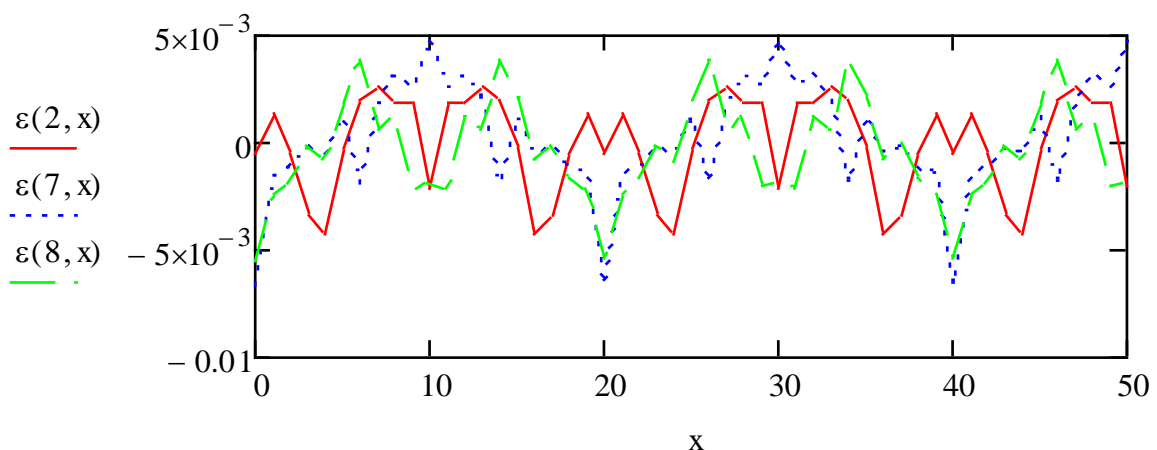

**Figure 1.** Change in deformation depending on the x coordinate for fixed values of t.

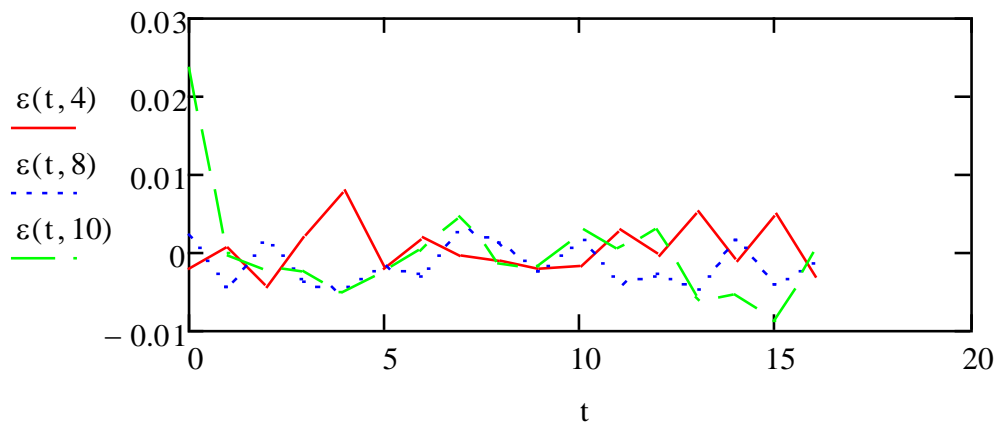

**Figure 2.** Change of deformation depending on time  $t$  for fixed values of coordinate  $x$ .

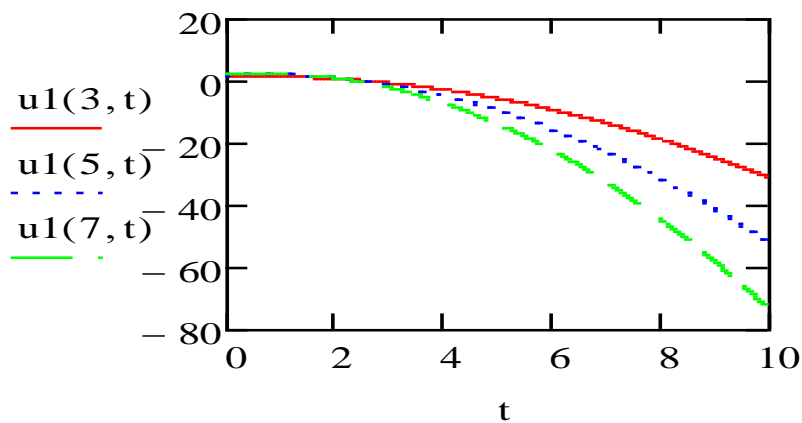

**Figure 3.** Change of displacement  $u_1(x, t)$  depending on the time  $t$  for fixed values of coordinate  $x$ .

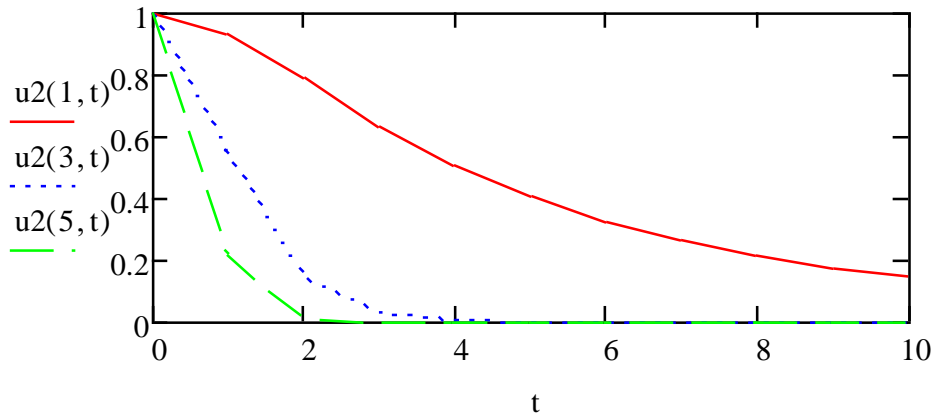

**Figure 4.** Changes in displacement  $u_2(x, t)$  depending on time  $t$  for fixed values of  $x$ .

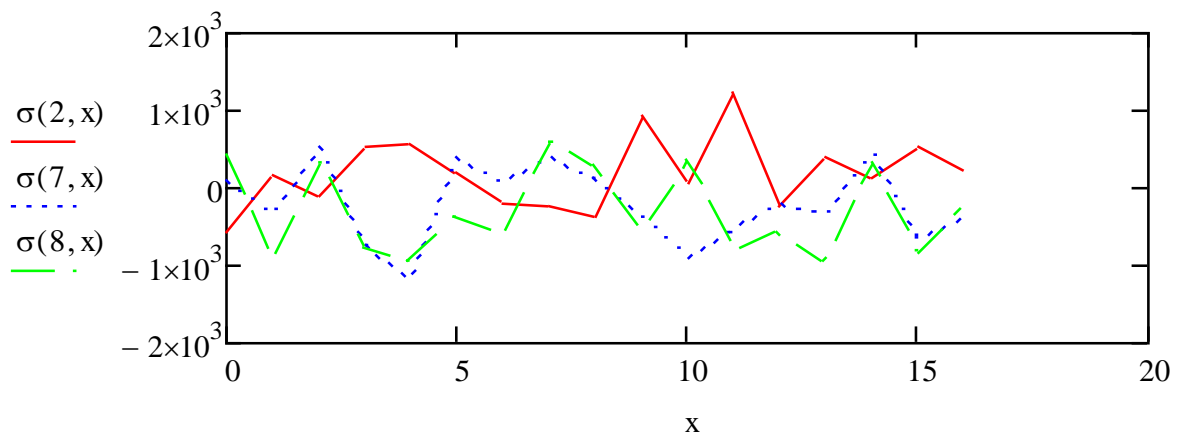

**Figure 5.** Change in voltage depending on the  $x$ -coordinate for fixed values of time  $t$ .





## Conclusions

1. The main relations of the classical theory of viscoelasticity were given.
2. Graphs that characterize changes in displacement, strain, and stress as a function of time for fixed values of the coordinate  $x$  were constructed.
3. Graphs that characterize changes in displacement, deformation and stress depending on  $x$  for fixed values of time  $t$  were constructed
4. The results obtained allow calculating the values of displacement, strain and stress for an arbitrary moment of time  $t$  and coordinate  $x$ .

## References:

- [1] Mavlanov T. "Development of methods and algorithms for calculating shell structures taking into account structural heterogeneity and interaction with various environments," *Tashkent* 2020, p. 200.
- [2] Abdieva G., Adizova A., Mavlanov T., Rakhimova D. "Modeling the process of deformation of viscoelastic textile materials," *Academica. An International Multidisciplinary Research Journal*, Vol. 11, Issue 4, April 2021, pp. 322-327.
- [3] Adizova A., Abdieva G., Mavlanov T. "Modeling the process of deformation of viscoelastic threads," *Scopus "AIP Conference Proceedings"*, Vol. 2402, Issue 1, 2021, p. 070034.
- [4] Adizova A.J. "Determination of tension characteristics of composite materials under static and dynamic loading," *Scientist of the xxi century, International scientific journal*, № 5-1 (86), 2022, pp. 4-5.
- [5] Salimov Sh.M., Yusupov G.U., Abdiyeva G.B. "Computer modeling of strain process of flexible rods with nonlinear and viscoelastic characteristics," *International Scientific Conference, Construction Mechanics, Hudraulics and Water Resources Engineering CONMECHYDRO*, 2020.
- [6] Adizova A.J. "Solution of problems of linear theory of thermoviscoelasticity," *Scientist of the xxi century, International scientific journal*, № 5-1 (86), 2022, pp. 6-8.
- [7] Mavlanov T. and Khudainazarov Sh. "Calculation of structural-inhomogeneous multiply connected shell structures with viscoelastic elements," *E3S Web of Conferences* 97, 04054, 2019, p. 9.
- [8] Abdieva G.B. "Deformation of viscoelastic thread with nonlinear characteristics," *International scientific-educational electronic journal, Education and science in the XXI century* 2021.
- [9] Adizova A., Abdieva G., Mavlanov T. "Computer modelling of dynamics of the thread in technological process," *Journal of Physics: Conference Series*, Vol. 2373, №-2, December 2022, p. 022060.
- [10] Adizova A.J. "Mechanical properties of textile materials with various manifestations of deformation over time," *Scientist of the xxi century, International scientific journal*, № 9 (80), 2021, pp. 8-10.
- [11] Adizova A.J. "Vibration impact processing of machine parts," *Scientist of the xxi century, International scientific journal*, № 12-2(71), 2020, pp. 13-16.



UDC:004.41, 004.42, 004.45, 164, 6, 378

**INNOVATIVE APPROACH TO MATHEMATICAL MODELING OF  
LEARNING PROCESSES AS AN OBJECT OF DIGITAL TECHNOLOGY  
(using advanced training as an example)**

**Jurakulov Tolib**

*Teacher, Navoi state pedagogical  
institute*

[jurakulov89@inbox.ru](mailto:jurakulov89@inbox.ru)

**Isroilova Lola**

*PhD, Navoi state pedagogical institute*

[lola.isroilova.90@mail.ru](mailto:lola.isroilova.90@mail.ru)

**Sadullayeva Maftuna**

*Student, Navoi State Pedagogical  
Institute*

[maftunasadullayeva302@gmail.com](mailto:maftunasadullayeva302@gmail.com)

**Annotatsiya.** Ushbu maqolada o'quv jarayonida raqamli texnologiyalarning qo'llanilish muammosi OTM misolida ko'rib chiqilgan. Masalaning matematik modeli tizimli tahlil va to'plamlar nazariyasi elementlaridan foydalangan holda ishlab chiqilgan. Muammoni yechish uchun hisoblash algoritmi tuzilagan hamda amaliy tavsiyalar berilgan.

**Kalit so'zlar:** tizim, tizimli yondashuv, o'quv jarayoni, obyekt, predmet, mutaxassis o'qituvchi, matematik model, to'plam, kichik to'plam, kesishish, birlashma, axborot matritsasi, algoritm, hisoblash tajribasi.

**Аннотация.** В статье рассматривается прикладной задачи цифровой технологии процесса обучения, на примере ВУЗ. Разработана математическая модел задачи с применением системного анализа и элементы теории множеств. Создан вычислительный алгоритм решения задачи, даются практические рекомендации.

**Ключевые слова:** система, системный подход, процесс обучения, объект, субъект, специалист-преподаватель, математическая модель, множество, подмножество, пересечение, объединение, информационная матрица, алгоритм, вычислительный эксперимент.

**Abstract.** The article considers the applied problem of digital technology of the learning process, using the example of a university. A mathematical model of the problem has been developed using system analysis and elements of set theory. A computational algorithm for solving the problem has been created, and practical recommendations are given.

**Keywords:** system, systems approach, learning process, object, subject, specialist teacher, mathematical model, set, subset, intersection, union, information matrix, algorithm, computational experiment.



## Introduction

Modeling of the processes under study from the perspective of a systems approach, as socio-economic and biological systems, led to the emergence of the concept of a complex control system with a given hierarchical structure and led to the formulation of a number of applied problems of systems analysis specific to these systems [1, 2].

For this purpose, issues related to the study of processes of mathematical modeling and information support in complex systems are considered. Since when choosing any control law, three main tasks are solved: obtaining information about the object under study, transforming it for the purpose of synthesizing the control law and issuing it to the object. Note that the division of a complex control system into subsystems is due to the large dimensionality of such systems and the resulting difficulties associated with the collection and processing of information about their state when choosing control actions [1, 2].

The socio-economic sectors of the country as a continuously developing system and they can be represented as a complex management system. One of the subsystems of this system are the higher educational institutions (HEI) of the country.

## Research Methodology

As the complexity of systems increases, problems arise that are less related to the consideration of the properties and laws of functioning of elements, and more related to the choice of the best structure, the optimal organization of the interaction of elements, the determination of optimal modes of their functioning, taking into account the influence of the external environment, etc. [1-3]. Therefore, it is advisable to use a systems approach when solving applied problems of analysis and synthesis of learning processes in higher education institutions. The systems approach of control theory is based on the creation of a control structure and mathematical modeling using similarity theory, the theory of scientific experiment, set theory, mathematical statistics, the theory of algorithms and a number of other fundamental classical theories. At the same time, in the field of designing modern information and control systems and computer software, the so-called object-oriented approach is increasingly used in the analysis and synthesis of complex systems [4-6].

Thus, the main purpose of an abstract description in design is to construct a meaningful description of the processes of functioning of the object of study. A meaningful description in verbal expression concentrates information about the tasks solved during the functioning of the control object, about the subsystems included in the developed system and the subtasks solved by them, about the degree and nature of interaction between subsystems in the general process of functioning of the system as a whole, about the criteria taken into account in design, about the parameters determining the functioning of both subsystems and the system as a whole, about external disturbing effects and about restrictions on both some criteria and on the parameters of the system, etc [7, 8] .

In the social sphere (branch) of management, as a higher education institution, the management structure is organized in a hierarchical form of functioning, i.e. a centralized management system. To create a mathematical model of the management processes of improving the qualifications of specialist teachers, as a subsystem of a

complex management system, the principle of the system approach of management theory with elements of the theory of sets of functional analysis is used [3]. As the objects of management under study, we can consider a higher education institution, as  $n$  subjects of the country. The mathematical designation of these objects can be formulated as follows  $A_1, A_2, A_3, \dots, A_l$ . Through  $A_k$  designated university  $k$  – industry [9, 10]. Here  $A_k, k = \overline{1, l}$  is the union of a finite number of non-self-intersecting sets, i.e. the following holds:

$$A = \bigcup_{k=1}^l A_k, A_i \cap A_{i+1} = \emptyset.$$

A bunch of  $A$  consists of subsets  $A_1, A_2, A_3, \dots, A_l$  the elements of these subsets are

$$B_{i,j}^k, (k = \overline{1, l}, i = \overline{1, m}, j = \overline{1, n}),$$

these elements mean that  $j$  – oh university  $i$ - th ministry and department in  $k$ - m region (or area).

A bunch of  $A_k$  is defined as follows

$$A_k = \bigcup_{i,j} B_{i,j}^k, (k = \overline{1, l}, i = \overline{1, m}, j = \overline{1, n}).$$

and so many  $A_k$  consists of unions of a finite number of subsets

$$B_{i,j}^k, (k = \overline{1, l}, i = \overline{1, m}, j = \overline{1, n}).$$

As is known, in each university, in each department, there are many specialist teachers. In this case, the elements of the lower level of the hierarchy can be designated as follows:

$$B_{i,j}^k = \bigcup_{\alpha,\beta} C_{\alpha,\beta}^j, (j = \overline{1, n}, \alpha = \overline{1, s1}, \beta = \overline{1, s2})$$

here  $C_{\alpha,\beta}^j$  –  $\beta$  teacher, by specialty  $\alpha$ ,  $j$  - go university.

Information about the level of knowledge, qualifications and skills of each specialist-teacher of the university is always of interest to management personnel at the highest levels of the hierarchy.

Constant study and monitoring of information about the level (high, good, average, low) of knowledge of a specialist teacher is a necessary source of information for management specialists at the highest level of the hierarchy.

The functional task of this system is to form sources of information, collect and continuously process existing information, analyze this information and promptly transmit it to the first requests of management specialists at the highest level of the hierarchy.

In the work [9, 10] the concept of an information matrix is introduced, a definition is given and the general form of this matrix is presented..

$$C_{\alpha,\beta}^j = \|\sigma_{\alpha,\beta}\|, (\alpha = \overline{1, s1}, \beta = \overline{1, s2}).$$

Elements of the information matrix  $\sigma_{\alpha,\beta}$  is information about the knowledge of specialist teachers, which is formed at low levels of the management hierarchy and is constantly stored in a database organized at higher levels of the hierarchy.

For each  $\sigma_{\alpha,\beta}$  an information matrix is filled in, the row elements of which are sections (or parts) of individual theoretical knowledge, and the column elements are the numbers of questions in these sections or parts.

Elements of matrices  $C_{\alpha,\beta}^j$  are formed as follows [9]:



$$\sigma_{1,\beta} = \|a^{(1)}i, j\|, \sigma_{2,\beta} = \|a^{(2)}i, j\|, \dots, \sigma_{s1,\beta} = \|a^{(s1)}i, j\|, i = \overline{1, m_1}, j = \overline{1, n_1}.$$

Preparation of information is carried out in the following sequence.

For all  $\sigma_{\alpha,\beta}$ , elements  $a_{i,j}$  is formed as the sum of the numbers 1 and 0 and the condition is checked

$$\sum_{i=1}^{m_1} a^{(1)}i, j < K \quad j = \overline{1, n_1} \quad (1)$$

( $K$  given, constant value), if the condition is met, then  $\sigma_{1,\beta} = 0$ , otherwise  $\sigma_{1,\beta} = 1$  goes to the next line, and condition (1) is checked and executed  $\sigma_{2,\beta} = 1$  or  $\sigma_{2,\beta} = 0$ , etc.  $\sigma_{s,\beta} = 1$  or  $\sigma_{s,\beta} = 0$ , are formed as elements of rows and columns of the information matrix. For each specialist-teacher for each job position, an information matrix is formed on the degree and knowledge and experience for the job position.

### Analysis and Results

An information matrix consisting of elements is filled in and an analysis of the computational experiment is carried out. Filled information matrices consisting of data analysis information at low levels of the hierarchy are re-analyzed at the middle and highest levels of the hierarchy. As a result of the conducted analyses of statistical data processing, plans are created for improving the qualifications of specialist teachers for the new academic year, from each university. And a decision is made on planning advanced training related to the issues of what number of specialist teachers, for what period of time should be sent for advanced training [11, 12].

To form elements of information matrices, it is advisable to conduct computational experiments of statistical data at low levels (at faculty levels) of the hierarchy in the following sequence:

- the information matrix is filled in and the data is saved in the database;
- an organization is created for the time of testing the specialist-teacher on which specialists, for what period, and this plan is drawn up by the corresponding order of the human resources department of the university;
- for all specialties of a separate faculty, groups of experts prepare testing assignments (tests);
- the tasks of analysis are solved using an information matrix created (formed) as a result of testing specialist teachers;
- Experts classify (or group) according to the results of the analysis of the results of testing on the knowledge and skills of specialist teachers.

After carrying out the above sequences according to specific plans, the experts transmit information to the ministry and department about sending a specialist teacher to advanced training courses.

The given sequence of formation of elements of information matrices using computational experiments can be applied in most socio-economic systems.

The head of the university makes a decision on improving the qualifications of teaching specialists for the academic year and the prepared statistical data is transferred to the personnel department of the Ministry of Education and Science and the department.



## Conclusions

The developed system of management of advanced training of specialists of the higher educational institution is an open system, since the structure of the system can be continuously supplemented with additional elements and adjusted for application to other classes of production and social objects of management, in particular continuous professional development of teachers of specialists, where advanced training of specialists (or employees) is required.

## References:

- [1] Moiseev N.N. “Elements of the theory of optimal systems,” Moscow: *Nauka*, 1975, p. 526.
- [2] Moiseev N.N. “Mathematical problems of systems analysis,” Moscow: *Nauka*, 1981, p. 488.
- [3] Samarsky A.A., Mikhailov A.P. “Mathematical modeling: Ideas. Methods. Examples,” Moscow: *Fizmatlit*, 2001, p. 343.
- [4] Mikhalevich V.S., Volkovich V.L. “Computational methods for studying and designing complex systems,” Moscow: *Nauka*, 1982, p. 287.
- [5] Buslenko N.P. “Modeling of complex systems,” Moscow: *Nauka*, 1968, p. 356.
- [6] Shannon R. “Simulation Modeling of Systems – Art and Science,” trans. from English. Moscow: *Mir*, 1978, p. 302.
- [7] Peregudov F.I., Tarasenko F.P. “Introduction to systems analysis,” M.: *Higher school*, 1989, p. 367.
- [8] Dvoretzky S.I., Muromtsev Yu.L., Pogonin V.A. “Modeling of systems,” Moscow: *Publishing center “Academy”*, 2009, p. 320.
- [9] Suvonov O.O., Juraklov T.T. “Mathematical model and algorithm of calculation of the management processes of professional development in industries,” VII International scientific specialized conference. *International scientific review of the technical sciences, mathematics and computer science*, Boston, USA. 12 November 2018.
- [10] Suvonov O.O., Jurakulov T.T. “Mathematical model and algorithm for calculating the management processes of advanced training of specialists in the mining industry,” Problems of optimization of complex systems. *Proceedings of the XIV International Asian School-Seminar*. Part 2, 2018.
- [11] Suvonov O.O., Juraklov T.T. “On one problem of mathematical modeling of learning processes as an object of management,” *Electronic journal of actual problems of modern science, education and training*. June-III, 2020. ISSN 2181-9750.
- [12] Suvonov O.O., Juraklov T.T. “Mathematical Modeling of Learning Processes Based on the Theory of Control,” *Central Asian journal of mathematical theory and computer sciences*, Vol. 03, Issue 04, Apr. 2022, ISSN: 2660-5309.



UDC:548.5, 549, 57.04

## PECULIARITIES OF $(\text{Ge}_2)_{0,02}(\text{ZnSe})_{0,03}(\text{GaAs})_{0,95}$ SOLID SOLUTIONS PREPARATION AND THEIR PHOTOELECTRIC PROPERTIES

**Alijon Razzokov**

Doctor of Science (DSc), Department of Physics, Urgench State University

**Maxbuba Sotimova**

Master student, Department of Physics, Urgench State University

[satimovamahbuba@gmail.com](mailto:satimovamahbuba@gmail.com)

**Annotatsiya.** Yangi qattiq qorishmalar  $(\text{Ge}_2)_{0,02}(\text{ZnSe})_{0,03}(\text{GaAs})_{0,95}$  epitaksial qatlamlarining fotoelektrik xossalarini va ular asosida suyuq fazali epitaksial usulda olingan strukturalarni o'rganish natijalari keltirilgan. Fotosezgirlik  $1.38 \div 2.58$  eV spektral diapazonda kuzatiladi, bu  $(\text{Ge}_2)_{0,02}(\text{ZnSe})_{0,03}(\text{GaAs})_{0,95}$  qatlamda Ge donor energiya zonasi va elektron-teshik juftlarining n-p o'tishda ichki zona kaskad fotogeneratsiyasini ko'rsatadi.

**Kalit so'zlar:** kristallanish, o'zgaruvchan oraliq, qattiq qorishma, epitaksial qatlam.

**Аннотация.** Представлены результаты исследований фотоэлектрических свойств эпитаксиальных слоев новых твердых растворов  $(\text{Ge}_2)_{0,02}(\text{ZnSe})_{0,03}(\text{GaAs})_{0,95}$  и структур на их основе, полученных методом жидкофазной эпитаксии. Фоточувствительность наблюдается в спектральном диапазоне  $1.38 \div 2.58$  eV, что свидетельствует об образовании донорной энергетической зоны Ge и внутризонной каскадной фотогенерации электронно-дырочных пар в слое  $(\text{Ge}_2)_{0,02}(\text{ZnSe})_{0,03}(\text{GaAs})_{0,95}$  n-p перехода.

**Ключевые слова:** кристаллизация, градиентный зазор, твердый раствор, эпитаксиальные слои.

**Abstract.** The results of studies of photoelectric properties of epitaxial layers of new solid solutions  $(\text{Ge}_2)_{0,02}(\text{ZnSe})_{0,03}(\text{GaAs})_{0,95}$  and structures based on them obtained by liquid-phase epitaxial method are presented. Photosensitivity is observed in the spectral range of  $1.38 \div 2.58$  eV, indicating the formation of Ge donor energy band and interzone cascade photogeneration of electron-hole pairs in  $(\text{Ge}_2)_{0,02}(\text{ZnSe})_{0,03}(\text{GaAs})_{0,95}$  layer of the n-p transition.

**Keywords:** crystallization, graded-gap, solid solution, epitaxial layers.

### Introduction

By smoothly changing the composition of the solid solution, it is possible to control the main electrophysical and optical parameters of the material - the width of the forbidden zone, the spectral photosensitivity region, lattice parameters, etc. On the other hand, the proximity of the lattice parameters of the solid solution components is of great importance for obtaining a high-quality solid solution suitable for the creation of devices [1-3]. In this regard, the solid solution consisting of components GaAs, ZnSe and Ge is of undoubted interest, since the sum of covalent radii of atoms of molecules of these

semiconductors is very close ( $r_{\text{Ga}+\text{As}}=0.244$  nm,  $r_{\text{Zn}+\text{Se}}=0.245$  nm and  $r_{\text{Ge}+\text{Ge}}=0.244$  nm), and the values of forbidden zone widths in them ( $E_g$ ) differ significantly ( $E_{g\text{GaAs}} = 1.43$  eV,  $E_{g\text{ZnSe}} = 2.68$  eV and  $E_{g\text{Ge}} = 0.67$ eV) [4, 5].

The formation of the donor energy zone of narrow bandgap semiconductor compound  $A_2$  and AB in the forbidden zone of concentrated solid solution compounds of the  $(A_2)_x(\text{CD})_{1-x}$  and  $(\text{AB})_x(\text{CD})_{1-x}$  type at  $X=0.01\div 0.05$  was substantiated earlier [6].

The presence of the donor zone causes interzone cascade electron transitions from the donor zone to the permeability zone and from the valence zone to the donor zone. Therefore, the photo sensitivity of will cover the spectral range  $E_{gA_2}-E_{Gcd}$  hence, the realization of electronic transitions in would serve as a basis for the development of more efficient solar cells and photovoltaic cells of thermophotovoltaic converters. As an example, in [6] the  $(\text{Ge})_x(\text{GaAs})_{1-x}$  CTRS was considered.

To indirectly experimentally verify the formation of transitions, we determined the photosensitivity of several n-GaAs-p- $(\text{Ge}_2)_{0,02}(\text{ZnSe})_{0,03}(\text{GaAs})_{0,95}$  structures in the development of the studied n-GaAs-p- $(\text{Ge}_2)_{1-x}(\text{ZnSe})_x$  , structures in [7,8].

The possibility of the formation of a solid solution of molecular substitution between the GaAs, Ge and ZnSe components was estimated based on the generalized atomic moment ( $m^*$ ). When considering the generalized moment of the atom of a chemical element, geometric factors, the shell structure of the atom and the effective nuclear charge were taken into account.

The generalized moment as an important characteristic that takes into account the dimensional and energy parameters of atoms is of great importance in the formation of substitutional solid solutions.

The proximity of the generalized moments of the molecules of the components of the solid solution promotes the formation of more perfect solid solutions by molecular substitution.

The generalized moments of molecules of binary compounds are  $m^* = 86.29 \cdot 10^2$  C/m for GaAs,  $m^* = 76.32 \cdot 10^2$  C/m for ZnSe and  $m^* = 78.26 \cdot 10^2$  C/m for Ge. Their difference is less than 13%. This indicates that they can form a substitutional solid solution of the form  $(\text{Ge}_2)_{0,02}(\text{ZnSe})_{0,03}(\text{GaAs})_{0,95}$ . To grow such a solid solution between GaAs, Ge and ZnSe, thermodynamic conditions were created, which were achieved on the basis of the model of a liquid phase with molecular components proposed by Saidov.

According to this model,  $A^{III}B^V$  and  $A^{II}B^{VI}$  semiconductor compounds, as well as elementary semiconductors such as Ge and Si, when dissolved in metallic solvents at temperatures much lower than the melting point of the corresponding substances, are mainly in the form of molecules (Figure 1). The solubility of the binary compounds GaAs and ZnSe, as well as the atomic substances Ga, As, Zn, and Se, in tin at various temperatures was studied

The validity of this model for the selected Sn–GaAs–ZnSe system is confirmed by the fact that the binary compounds GaAs and ZnSe in tin have a very low solubility (Figure 2).

At the same time, their individual components, i.e., atomic substances Ga, As, Zn and Se, have unlimited or very high solubility in tin at the same temperatures. This result confirms that the binary compounds gallium arsenide and zinc selenide dissolved in tin



(Figure 3 and Figure 4) at 750 °C do not decompose into individual Ga and As atoms but, like Zn and Se, are in the form of GaAs and ZnSe molecules [7, 8].

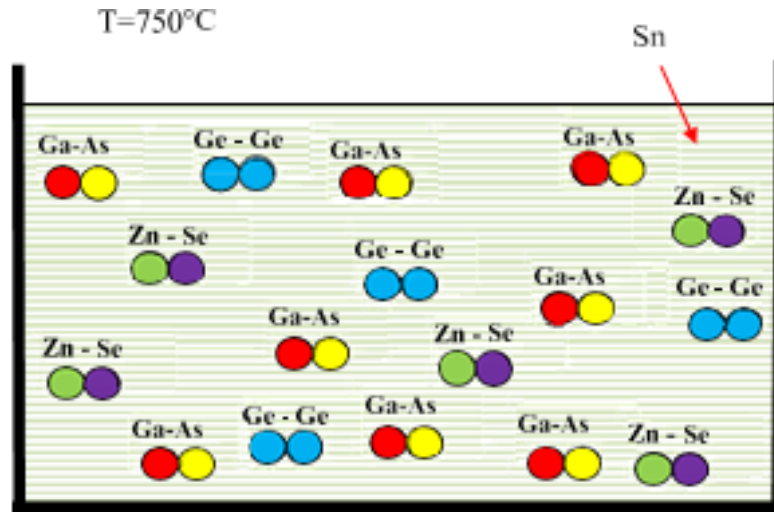

**Figure 1.** Dissolved molecules of GaAs, ZnSe and Ge<sub>2</sub> in tin at a temperature of 750 °C.

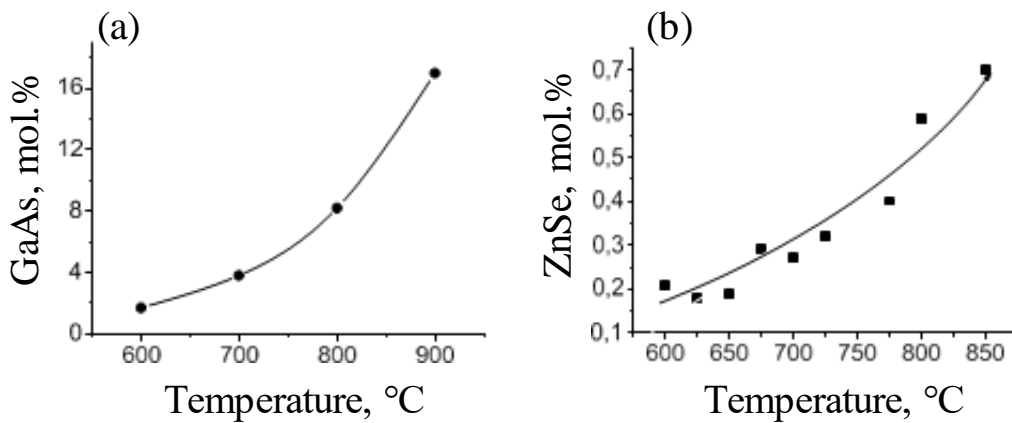

**Figure 2.** Temperature dependence of GaAs (a) and ZnSe (b) solubility in Sn.

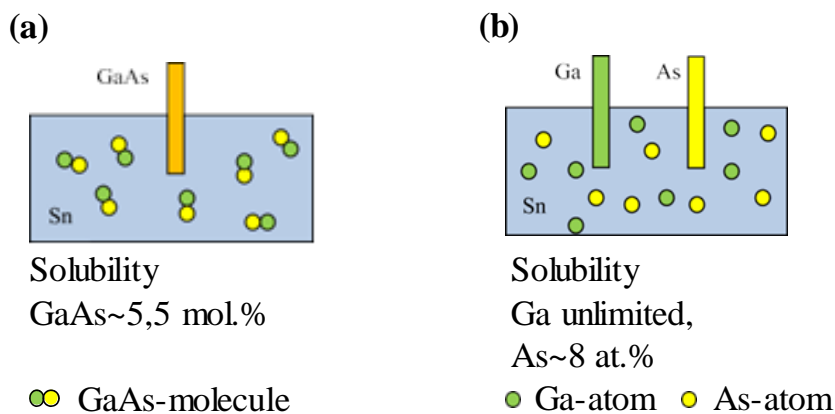

**Figure 3.** Dissolution of gallium arsenide in the form of GaAs molecules (a), as well as gallium and arsenic in the form of individual Ga and As atoms (b) in tin at a temperature of 750 °C.

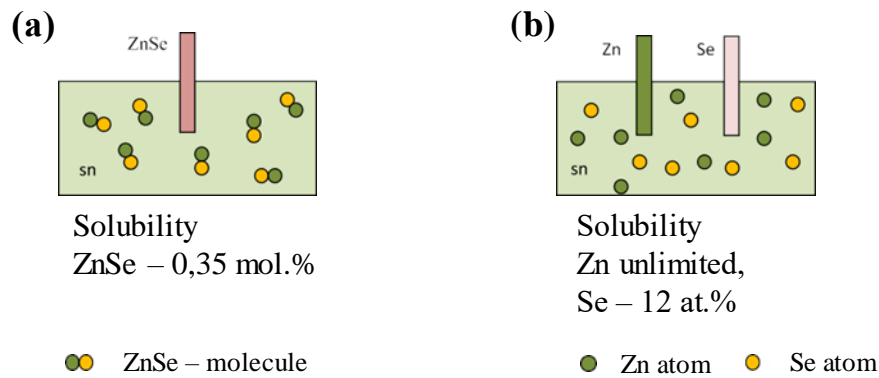

**Figure 4.** Dissolution of zinc selenide in the form of ZnSe molecules (a) and zinc and selenium in the form of individual Zn and Se atoms (b) in Tin at a temperature of 750 °C.

Epitaxial layers of solid solutions  $(\text{Ge}_2)_{0,02}(\text{ZnSe})_{0,03}(\text{GaAs})_{0,95}$  was grown by forced cooling from a tin melt solution confined to two horizontally arranged GaAs substrates oriented along the (100) directions. The composition of the Sn-GaAs-Ge-ZnSe melt solution was determined from preliminary solubility experiments. The epitaxy onset temperature was 700÷750 °C.

The thickness of epitaxial layers varied in the range of 4÷10  $\mu\text{m}$  depending on the thickness of the gap between the substrates and the growth mode depending on the thickness of the gap between the substrates and the growth mode. Assessment of epitaxial layers surface composition by X-ray microanalyzer of “Cameca” type is presented below in Table 1 [9, 10]:

**Table 1.** Elemental compositions taken from the surface of the samples.

Samples	Se	Ge	Ga	Zn	As
1	1,41	1,91	49,13	1,54	45,32
2	1,53	2,07	48,76	1,47	46,04
3	1,51	1,98	47,96	1,39	47,24

The perfection of the obtained epitaxial layers indicates that they are a solid solution of  $(\text{Ge}_2)_{0,02}(\text{ZnSe})_{0,03}(\text{GaAs})_{0,95}$  As expected, the crystalline perfection, other things being equal, significantly depended on the state of homogeneity of the melt solution at the moment of substrates immersion into it.

Raster patterns on characteristic X-ray emission of  $\text{Ka}(\text{Ge})$ ,  $\text{Ka}(\text{As})$ ,  $\text{Ka}(\text{Zn})$ ,  $\text{Ka}(\text{Se})$ , taken from epitaxial layers grown from molten solution without preliminary homogenization, showed their imperfection.

Sufficiently perfect epitaxial layers were obtained by preliminary annealing of Sn-Ge-GaAs-ZnSe melt-solution for 4 h at 750÷800°C

The obtained epitaxial layers had hole permeability type with hole concentration  $10^{17}\div 10^{18} \text{ cm}^{-3}$  and mobility  $15\div 20 \text{ V s/cm}^2$  at 300K. The electron concentration in the n-GaAs substrate was  $5 \cdot 10^{17} \text{ cm}^{-3}$ . Gold ohmic contacts were applied to the structures by vacuum sputtering and then their photoelectric properties were measured.

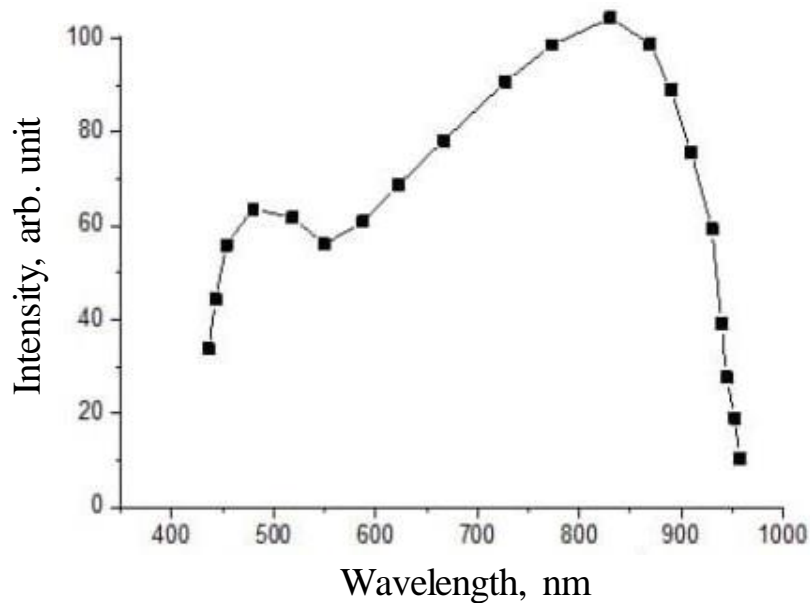

**Figure 5.** Spectral dependence of photocurrent n-GaAs-p-(Ge<sub>2</sub>)<sub>0.02</sub>(ZnSe)<sub>0.03</sub> structures measured in photodiode mode.

The photosensitivity of the nGaAs-p(Ge<sub>2</sub>)<sub>0.02</sub>(ZnSe)<sub>0.03</sub>(GaAs)<sub>0.95</sub> structure was measured in photodiode mode at 300 K and is shown in Fig.5. As can be seen, the photosensitivity is observed in the spectral range of 1.38÷2.58 eV, indicating the formation of Ge donor energy band and intrazone cascade photogeneration of electron-hole pairs in (Ge<sub>2</sub>)<sub>0.02</sub>(ZnSe)<sub>0.03</sub>(GaAs)<sub>0.95</sub> layer of the n-p transition.

#### References:

- [1] Suprun S.P., Sherstyakova V.N. "Epitaxy of ZnSe on GaAs as a Source of the ZnSe Compound," *Physics and Technology of Semiconductors*, Vol. 43, № 11, 2009, pp. 1570-1575.
- [2] Wang L. G., Zunger A. "Dilute nonisovalent (II-VI)-(III-V) semiconductor alloys: Monodoping, codoping, and cluster doping in ZnSe-GaAs," *Physical Review B*. Vol. 68, № 12, 2003, p. 125211.
- [3] Balch J.W., Anderson W.W. "Liquid phase epitaxy of gallium arsenide on zinc selenide," *Journal of Crystal Growth*, Vol. 15, № 3, 1972, pp. 204-210.
- [4] Saidov A.S. et al. "Structural Studies of the Epitaxial Layer of a Substitutional Solid Solution (GaAs)<sub>1-x</sub>(ZnSe)<sub>x</sub> with Nanocrystals," *Advances in Materials Science and Engineering*, 2019, pp. 1-9.
- [5] Saidov A.S. et al. "Features of liquid-phase epitaxy of new solid solutions of (GaAs)<sub>1-y-z</sub>(Ge<sub>2</sub>)<sub>y</sub>(ZnSe)<sub>z</sub> and their photoelectric properties," *International Journal of Modern Physics B*. Vol. 37, № 14, 2023, p. 2350132.
- [6] Saidov M.S., Saidov A.S., Razzakov A.Sh. "Liquid phase epitaxy photoluminescence and photoelectrical properties of variband (Ge<sub>2</sub>)<sub>1-x</sub>(ZnSe)<sub>x</sub> layers," *Proceedings of SPIE-The International Society for Optical Engineering*, 2000, pp. 3975-3976.
- [7] Saidov M.S., Saidov A.S., Razzakov A.Sh. "Liquid Phase Epitaxy Photoluminescence and Photoelectrical Properties of Variband (Ge<sub>2</sub>)<sub>1-x</sub>(ZnSe)<sub>x</sub> Layers," *Tenth International Workshop on Physics of Semiconductor Devices*. India, December 14-18, 1999, pp. 1424-1427.



- [8] Saidov A.S. et al. "Features of liquid-phase epitaxy of new solid solutions of  $(\text{GaAs})_{1-y-z}(\text{Ge}_2)_y(\text{ZnSe})_z$  and their photoelectric properties," *International Journal of Modern Physics B*. Vol. 37, № 14, 2023, pp. 2350132.
- [9] Yim W. M. "Solid Solutions in the Pseudobinary (III-V)-(II-VI) Systems and Their Optical Energy Gaps," *Journal of Applied Physics*. Vol. 40, № 6, 1969, pp. 2617-2623.
- [10] Andreev V.M., Dolginov L.M., Tretyakov D.N. "Jidkoctnaya epitaksiya v texnologii poluprovodnikovyx priborov," M, *Izdatelctvo Sovetskoe radio*. 1975, pp. 35-44.

UDC: 004.04, 004.42, 681.5

## AUTOMATIC SUMMARIZATION OF TEXT IN UZBEK LANGUAGE USING KEYWORDS

**Bekchanov Shukurla Kurbanbayevich**  
*Lecturer at the Department of Computer  
Science, Urgench State University*  
[Shukurla15@gmail.com](mailto:Shukurla15@gmail.com)

**Annotatsiya.** Matni xulosalashtirish - bu tabiiy tilning soʻzlashishdagi vazifasi boʻlib, u berilgan matnning zichlashtirilgan versiyasini yaratish uchun kompyuterdan foydalanishni oʻz ichiga oladi. Tuzilgan natija xulosa sifatida maʼlum boʻlib, u butun matnning adolatli qayta koʻrinishi boʻlishi kerak, yaʼni u asl matndan eng muhim tafsilotlarni oʻz ichiga olishi kerak. Katta maʼlumot mazmuni kabi maʼlumotlarning boshqa shakllarini ham umumlashtirish mumkin. Matni umumlashtirish ushbu maqolaning asosiy mazmunidir. Bunday holda, matnli kalit soʻzlarni oʻz ichiga olgan jumlar matn jamlovchisining asosiy qismini tashkil qiladi.

**Kalit soʻzlar:** *TF-IDF, matn xulosalovchi, kalit soʻzlar, n grammlar, nomuhim soʻzlar.*

**Аннотация.** Суммаризация текста — это задача в обработке естественного языка, которая включает использование компьютера для создания сжатой версии заданного текста. Полученный результат известен как резюме, и он должен быть справедливым представлением всего текста, то есть он должен включать наиболее важные детали из исходного текста. Другие формы данных, такие как Скак большой объем информации, также могут быть резюмированы. уммаризацией текста является основной темой данной статьи. В данном случае предложения, содержащие текстовые ключевые слова, составляют большую часть суммаризация текста.

**Ключевые слова.** *TF-IDF, суммаризация текста, ключевые слова, n-граммы, стоп-слова.*





**Abstract.** Text summarization is a task in natural language processing that involves using a computer to create a condensed version of a given text. The result that is produced is known as a summary, and it ought to be a fair representation of the entire text—that is, it ought to include the most crucial details from the original text. Other forms of data, such as large information content, can also be summarized. Text summarization is the main topic of this thesis. In this instance, sentences containing textual keywords make up the majority of the text summarizer.

**Keywords:** *TF-IDF, text summarizer, keywords, n grams, stop words.*

## Introduction

The process of identifying relevant words or phrases within a given text in order to determine the text's topic is known as keyword extraction in natural language processing, and it is related to summarization in that both require the identification of semantic connections within the text; the more accurate the semantic representation of the text, the more accurate the summary, as it does not depend only on identifying relevant whole sentences but also on their essential meaning, which enables the combination of sentences to produce a higher-quality summary.

Text must be converted into numbers, a format that computers can comprehend, in order to be presented to a computer. Text encoding must be done before using any type of model, whether it is machine learning-based or numerical. There are several methods for doing this.

Text is often divided into words and then sentences. We refer to this process as text segmentation. It may be accomplished in two ways: simply using regular expressions, or more sophisticatedly with machine learning models. The primary idea is to break up the original text into smaller, easier-to-manage chunks, like words.

The following stage involves converting words into integers or, more frequently, vectors that the model will use to represent them. This is a challenging undertaking that falls under the umbrella of natural language processing. To achieve this, there are several methods. Among the most often used techniques are word embeddings and TF-IDF.

## Literature Review

Automatic inference of the text was originally the result of research by Hans Peter Luhn in the 1950s. For the first time, Luhn created a model for inference of scientific and technical articles [2]. Inspired by his work, many other studies have been done. For example, those who have developed an automatic inference system using methods for selecting and removing sentences [3]. The Uzbek language belongs to the family of agglutinative languages, and most of the methods of concluding the text for reflective languages cannot be directly applied to the Uzbek language. In recent years, research has been conducted on the process of processing natural languages in the example of the Uzbek language is presented [4]. A syntactic analysis of the sentence to the study of the process of natural language processing of the Uzbek language [5]; accuracy of stop words [6]; assimilation and lemmatization of the Uzbek language [7] are cited in such research work. Recent growth trends in the production of NLP-related research work

and resources, including machine transliteration tools [8], sensory analysis datasets, and analyzer models [9] are observed in Uzbek. It is also cited in the work of the semantic assessment dataset [10]. The article [11] examines the complex task of automating the transformation of dialect word forms into their standard literary analogs in the Uzbek language. This is a serious problem because the Uzbek language has a wide range of dialects, each with its own unique linguistic features. These dialectal variations can create barriers to communication and standardization of language, which are critical for effective linguistic and academic purposes. The authors developed a morphological analysis algorithm that uses a dictionary approach using two specialized databases. These databases contain words from the North Oguz and South Khorezm dialects of the Uzbek language and their corresponding standard literary forms. The algorithm works by comparing dialect word forms against these databases to find their standard equivalents. This process involves complex morphological analysis and conversion of word forms, largely dependent on the completeness and accuracy of the databases. This approach is designed to bridge the gap between dialects and the literary language, expanding the communicative and research capabilities of the Uzbek language. Devoted to automated inference from Uzbek texts using the TF-IDF approach [12]. This article presents a text summarization model and an approach based on the TF-IDF (Term Frequency-Inverse Document Frequency) algorithm, as part of the second approach to automatically summarize texts in Uzbek [13].

A significant drawback of the proposed solution is its strong dependence on databases. The algorithm shows high accuracy for words present in the database, but its performance drops noticeably for words not included in the database. This limitation suggests the need to continually update and expand databases to cover a wider range of dialect words.

### **Research Methodology**

There are more sophisticated approaches that capture the frequency of word occurrence in text, which is a significant and informative characteristic. This method of encoding words is restricted. One such technique creates a vector by combining two scores: term frequency, which counts the number of times a word appears in a document, and document frequency, which counts the number of documents the word appears in. This score is greater for more precise, highly significant terms and lower for frequent words like stop words since a word is deemed less relevant if it appears in multiple texts. Because popular words exist in most papers, if not all of them, and often at that, finding the right balance when grading terms based on their frequency of occurrence can be challenging. However, words that are reflective of the text topic also frequently appear. Stop words are typically eliminated from texts because of this.

Word embeddings, which are usually real-valued vectors that represent words so that words closest to each other in meaning are represented by vectors that are closer to each other in the embedding space, are a more complex approach to represent words with vectors. Closeness is formalized since the resultant embedding space may be seen as a subset of  $R^n$ .

Let the text be given. The text contains sentences,  $u_1, u_2, \dots, u_n$  ( $n$  is the number of sentences in the text), where  $n$  is the text's total number of sentences.  $u_{ij}$  ( $i$ -sentences, words inside the  $j$ -sentence) is used to express the words in the sentences. We create a dictionary of distinct terms from each of the text's  $u_{ij}$  words. Through  $a_k$ , we speak for them. We compute the value of the words TF-IDF at  $a_k$ .

$$TF(a_i) = \frac{k_j}{h_j},$$

where  $h_j$ - is the number of words in the  $j$  document.  $k_j - a_i$ - is the number of repetitions of a word in document  $j$ .

Reverse document frequency IDF (Inverse Document Frequency) is defined as the number of texts (documents) being viewed and the presence of a given word in selected texts documents:

$$IDF(a_i) = \ln\left(\frac{M}{m}\right),$$

where  $M$  is the total number of documents,  $m$  is the number of documents containing  $a_i$ .

To calculate the weight of each word, we multiply the TF values by the IDF values, respectively, and get the middle arithmetic for the total documents:

$$TF - IDF(a_i) = \frac{1}{n} \sum_{j=1}^n TF_j(a_i) * IDF(a_i) \quad (1)$$

Through this, it is determined whether each word is important or imperfect depending on its weight, but this is not always true. In the course of the research, it became clear that by normalizing the TF-IDF value of all words in the text, we can clearly say that they are important or stop words. We calculate it using the formula:

$$p_k = \frac{TF-IDF(a_i)}{\sum_{j=1}^n TF-IDF(a_i)} \quad (2)$$

Unlike our previous article [12], stop words are determined for the given text. then we can extract up to 10 keywords from the text. They (2) are mainly calculated according to the following formulas:

$$E = \sum_{k=1}^m k * p_k \quad \text{the mathematical expectation of the words,}$$

$$D = \sum_{k=1}^m (k - E)^2 * p_k \quad \text{– dispersion of the words,}$$

$$\sigma = \sqrt{D} \quad \text{– standard deviation of the words,}$$

$$E_t = \sum_{k=1}^m p_k * k^t \quad \text{– k-th raw moments of the words,}$$

$$\mu_3 = E_3 - 3 * E_1 * E_2 + 2 * E_1^3 \quad \text{– third central moment of the words.}$$

(1) and (2) we mainly cite the algorithm of the method of inference of the Uzbek text.

Based on the above, we can distinguish the  $c_1, c_2, \dots, c_{10}$  keywords. We find sentences with keywords extracted from the main text and bring a new text2. We create a text summarizer by applying n-gramms to text 2.

## Analysis and Results

The described values extracted from the text are presented in Table 1.

**Table 1.** Basic statistical properties extracted from the text.

$E$	$D$	$\sigma$	$\sigma^3$	$E_1$	$E_2$	$E_3$	$\mu_3$
23310,74	23310,74	13623,72	2,52864E+12	23310,74	728996416,52	25687931167881,50	41266663785,91

The stop words are distributed along the axis (not grouped at one part of the axis); represented by orange dots in Figure 1.

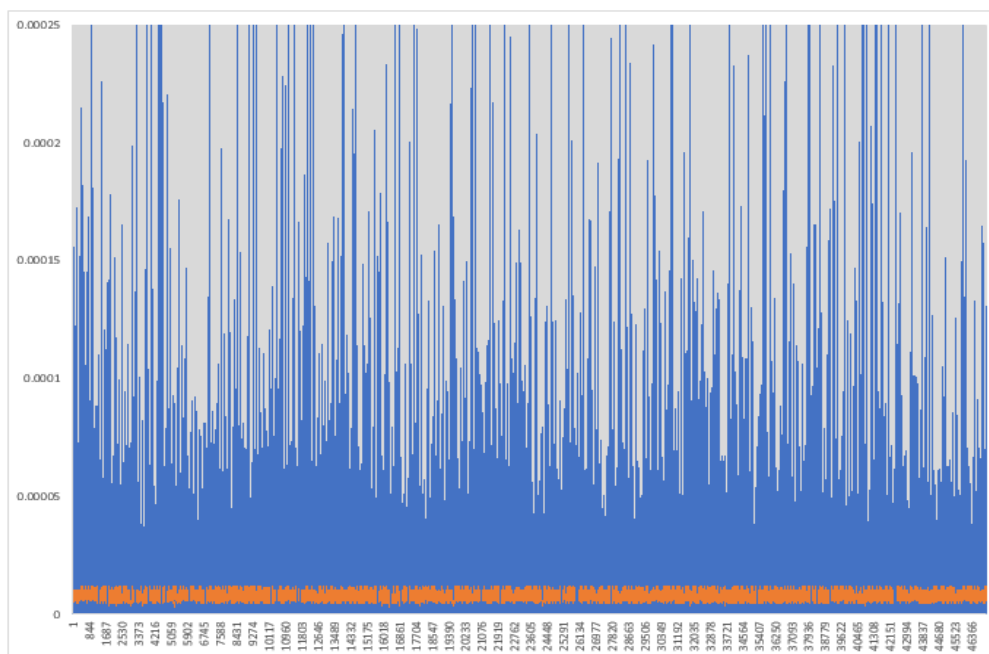

**Figure 1.** The orange dots indicate the positions of stop words along with the text.

## Conclusions

The selected model is applied as the last stage in creating a summary. For this goal, proven methods are presented in this thesis. Machine learning is a great alternative to the traditional numerical models because it can handle complex tasks including natural language, which cannot be well explained by a limited set of rules.

## References

- [1] Torres-Moreno J. “Automatic text summarization,” London, UK : Hoboken, NJ: ISTE Ltd ; *John Wiley & Sons, Inc.* 2014.
- [2] Luhn H.P. “The Automatic Creation of Literature Abstracts,” *IBM Journal of Research and Development*, 1958, pp. 159-165.
- [3] Edmundson H. & Wyllys R. “Automatic abstracting and indexing—survey and recommendations,” *Commun. ACM*, 4(5), 1961, pp. 226–234.
- [4] Madatov K., Bekchanov S., & Vičić J. “Dataset of stopwords extracted from Uzbek texts,” *Data in Brief*, 43, 2022.





- [5] Matlatipov G., Vetulani Z. “Representation of Uzbek Morphology in Prolog. In: Marciniak, M., Mykowiecka, A. (eds) Aspects of Natural Language Processing,” Springer, Berlin, Heidelberg, *Lecture Notes in Computer Science*, Vol. 5070, 2009.
- [6] Madatov K., Bekchanov S., & Vičič J. “Accuracy of the Uzbek Stop Words Detection: a Case Study on School Corpus,” *CEUR Workshop Proceedings*, 3315, 2022, pp. 107 – 115.
- [7] Sharipov M., Sobirov O. “Development of a rule-based lemmatization algorithm through Finite State Machine for Uzbek language,” *CEUR Workshop Proceedings*, 3315, 2022.
- [8] Salaev U., Kuriyozov E., & Gómez-Rodríguez C. “SimRelUz: Similarity and Relatedness scores as a Semantic Evaluation Dataset for Uzbek Language,” 1<sup>st</sup> Annual Meeting of the ELRA/ISCA Special Interest Group on Under-Resourced Languages, SIGUL 2022 - held in conjunction with the International Conference on Language Resources and Evaluation, *LREC 2022 - Proceedings*, pp. 199 – 206.
- [9] Matlatipov S., Rahimboeva H., Rajabov J., & Kuriyozov E. “Uzbek Sentiment Analysis Based on Local Restaurant Reviews,” *CEUR Workshop Proceedings*, 3315, 2022, pp. 126 – 136.
- [10] Salaev U., Kuriyozov E., & Gómez-Rodríguez C. “A Machine Transliteration Tool Between Uzbek Alphabets,” *CEUR Workshop Proceedings*, 3315, 2022, pp. 42 – 50.
- [11] Mengliev D.B., Abdurakhmonova N., Hayitbayeva D., and Barakhnin V.B. “Automating the Transition from Dialectal to Literary Forms in Uzbek Language Texts: An Algorithmic Perspective,” 2023 IEEE XVI International Scientific and Technical Conference, *Actual Problems of Electronic Instrument Engineering (APEIE)*, Novosibirsk, Russian Federation, 2023, pp. 1440-1443.
- [12] Bekchanov Sh.K. “Automated summarizing of the uzbek text,” *Electronic journal of actual problems of modern science, education and training*, May-5, 2024, pp. 98-102.
- [13] Madatov K.A. and Bekchanov S.K. “The Algorithm of Uzbek Text Summarizer,” 2024 IEEE 25<sup>th</sup> International Conference of Young Professionals, *Electron Devices and Materials (EDM)*, Altai, Russian Federation, 2024, pp. 2430-2433.



UDC: 53, 53.01/.09, 538.9, 537.5

## FIRST PRINCIPLE STUDIES ON STRUCTURAL AND ELECTRONIC PROPERTIES OF GALLIUM PHOSPHIDE AND SOLID SOLUTION $(\text{Si}_2)_x(\text{GaP})_{1-x}$ .

**Amin Saidov**

*Professor (DSc), Academy of Sciences  
Tashkent, Physical-Technical Institute  
Uzbekistan  
[amin@uzsci.net](mailto:amin@uzsci.net)*

**Shukrullo Usmonov**

*Professor (DSc), Academy of Sciences  
Tashkent, Physical-Technical Institute  
Uzbekistan  
[sh\\_usmonov@rambler.ru](mailto:sh_usmonov@rambler.ru)*

**Shahzod Masharipov**

*PhD, Department of Physics, Urgench  
State University,  
[shahzodbekmasharipov6@gmail.com](mailto:shahzodbekmasharipov6@gmail.com)*

**Umida Asatova**

*PhD, Department of Physics, Urgench  
State University,  
[umida72@rambler.ru](mailto:umida72@rambler.ru)*

**Dadajon Saparov**

*PhD, Academy of Sciences Tashkent,  
Physical–Technical Institute Uzbekistan  
[dada@uzsci.net](mailto:dada@uzsci.net)*

**Annotatsiya.** Bu ishda galliy fosfidi (GaP) va  $(\text{Si}_2)_x(\text{GaP})_{1-x}$  qattiq qorishmaning strukturaviy va elektron xossalari zichlik funksional nazariyasi (Density functional theory(DFT)) yordamida modellashtirilgan. Bu usul yarimo'tkazgich materiallarning ayrim parametrlarini hisoblashning samarali va aniq usuli hisoblanadi. Gibrid funktsional almashinuv korrelyatsiyasi Heyd-Scuceria-Ernzerhof (HSE) taqiqlangan zona kengligini kam baholanishini tuzatish uchun ishlatilgan. Ushbu ishda GaP va  $(\text{Si}_2)_x(\text{GaP})_{1-x}$  qattiq qorishmaning panjara parametrlari, taqiqlangan zona kengligi hisoblab chiqilgan va tajriba qiymatlari bilan taqqoslangan.

**Kalit so'zlar:** zichlik funktsional nazariyasi (DFT), qattiq qorishma, panjara parametri, taqiqlangan zona kengligi.

**Аннотация.** В данной работе структурные и электронные свойства фосфида галлия (GaP) и твердого раствора  $(\text{Si}_2)_x(\text{GaP})_{1-x}$  были смоделированы с использованием теории функционала плотности (Density functional theory(DFT)). Этот метод является эффективным и точным методом расчета

некоторых параметров полупроводниковых материалов. Гибридный функциональный обмен-корреляция Heyd-Scuseria-Ernzerhof (HSE) использовался для коррекции недооценки ширины запрещенной зоны. В данной работе были рассчитаны параметры решетки и ширина запрещенной зоны GaP и твердого раствора  $(\text{Si}_2)_x(\text{GaP})_{1-x}$  и сравнены с экспериментальными значениями.

**Ключевые слова:** теория функционала плотности (DFT), твердый раствор, параметр решетки, ширина запрещенной зоны.

**Abstract.** In this work, the structural and electronic properties of gallium phosphide (GaP) and  $(\text{Si}_2)_x(\text{GaP})_{1-x}$  solid solution were modeled using the density functional theory (DFT). This method is an efficient and accurate method for calculating some parameters of semiconductor materials. The hybrid functional exchange-correlation Heyd-Scuseria-Ernzerhof (HSE) was used to correct the underestimation of the band gap. This work calculated and compared the lattice parameters and band gap of the GaP and  $(\text{Si}_2)_x(\text{GaP})_{1-x}$  solid solution with the experimental values.

**Keywords:** density functional theory (DFT), solid solution, lattice parameter, band gap.

## Introduction

The synthesis of solid solutions based on elementary semiconductors and chemical compounds is of interest to the development of modern semiconductor material science since the solid solution combines the advantages of each of the components. Firstly, this is due to the fact that for the production of high-quality but inexpensive semiconductor devices, it is necessary to grow epitaxial films of expensive semiconductor compounds  $A^3B^5$ , in particular GaP, on cheap Si substrates. Secondly, by smoothly changing the composition of the solid solution, it is possible to control the main parameters of the solid solution, such as the width of the forbidden zone, the lattice parameter, and so on. For example, if a solid solution consisting of gallium phosphide and silicon is synthesized, it will have values between the lattice parameters and the widths of the forbidden zones of the components of this solid solution. Also, in this case, the spectral sensitivity region of the synthesized solid solution is expanded than silicon p-n junctions and can be used to expand the spectral sensitivity region of silicon photoconverters, and this is important for the creation of LEDs, photodetectors, and high-temperature electronics devices.

## Literature Review

The temperature expansion coefficients for Si and GaP are  $2.6 \times 10^{-6}$  and  $4.65 \times 10^{-6} \text{ K}^{-1}$  [1] respectively. Due to the large difference in thermal expansion coefficients and lattice parameters of the Si substrate and the GaP film, film growth is technically difficult. To eliminate this drawback, a buffer layer is used. The buffer layer consists of a substitution solid solution  $(\text{Si}_2)_x(\text{GaP})_{1-x}$  ( $0 \leq x \leq 1$ ), whose composition smoothly changes from pure Si to GaP as the film grows.

The authors of the work [2] theoretically investigated the possibilities of forming continuous substitution solid solutions of the class  $(C_2^4)_x(A^3B^5)_{1-x}$  based on the

generalized moments of mutually substituting components and developed a technology for growing continuous solid solutions  $(C_2^4)_x(A^3B^5)_{1-x}$  from the liquid phase [3, 4].

In the work [5], the author synthesized a metastable graded-gap substitution solid solution  $(Si_2)_x(GaP)_{1-x}$ . In the work [6], epitaxy layers of solid solution  $(ZnSe)_{1-x-y}(Si_2)_x(GaP)_y$  ( $0 < x < 0.03$ ,  $0 < y < 0.09$ ) were grown up from the limited volume of tin solution-melting by method of liquid phase epitaxy. Profiles of distribution of components Si, Se, Zn, P, and Ga in grown up epitaxy layers are defined. In spectrum of the photoluminescence of surface of the solid solution at 5 K 2 peaks of radiation are found out. They are probably caused by compounds  $Si_2$  (1.67 eV) and GaP (2.21 eV). It has been shown that covalent coupling Si-Si and Ga-P cause impurity levels laying in the forbidden zone of the solid solution  $(ZnSe)_{1-x-y}(Si_2)_x(GaP)_y$ .

The main objective of this work is to compare the experimentally obtained results with the results calculated from first principles based on the density functional theory (DFT) to study the structural and electronic properties of the solid solution  $(Si_2)_x(GaP)_{1-x}$ .

### Research Methodology

The density functional theory (DFT) method is one of the most popular approaches in theoretical physics and quantum chemistry for calculating the electronic structure of multi-electron systems. In DFT calculations, the electron wave functions are represented as a sum of plane waves. Each plane wave has a certain kinetic energy, depending on its wave vector. The parameter *ecutwfc* sets an upper limit on the kinetic energy of plane waves that are included in the calculation. Wave functions with kinetic energy above this threshold are not taken into account. The parameter *ecutwfc* sets an upper limit for the kinetic energy of plane waves that are included in the calculation. Wave functions with kinetic energy above this cutoff are not taken into account. Convergence with respect to *ecutwfc* means choosing a cutoff energy value at which the calculation results (e.g., the system energy, lattice parameters, forces, and other physical quantities) cease to change significantly with increasing *ecutwfc*.

Various approximations are necessary for the practical use of DFT since the exact function describing the electron density is unknown.

Combining **GGA-PBEsol** (Generalized Gradient Approximation - PBEsol) and **HSE** (Heyd-Scuseria-Ernzerhof Hybrid Functional) in Density Functional Theory (DFT) calculations is a strategy used to leverage the strengths of both approaches for specific types of materials and properties. GGA-PBEsol (Generalized Gradient Approximation - PBEsol) is a variant of the Perdew-Burke-Ernzerhof (PBE) functional, specifically optimized for solid-state systems. HSE (Heyd-Scuseria-Ernzerhof Hybrid Functional) improves the accuracy of electronic structure calculations, in particular, band gaps in semiconductors and insulators, which are often underestimated by standard GGA functionals such as PBE or PBEsol.

GGA-PBEsol can be used to calculate structural parameters or for the system's primary geometry optimization, as it gives good results for the bulk properties of solids. After the structure is optimized, HSE can be used to calculate the electronic structure more accurately, including the calculation of the band gap and other electronic

properties, where conventional GGA functionals may be less accurate. This combined approach allows one to obtain reliable structural parameters using PBEsol and then use HSE to accurately describe the electronic structure and related properties.

All convergence and optimization calculations have been performed for primitive unit cells of GaP by using norm-conserving (NC) pseudopotentials in conjunction with the PBEsol exchange-correlation functional in density functional theory (DFT) calculations. Norm-conserving pseudopotentials are used to replace the core electrons in DFT calculations, allowing for more efficient and accurate simulations of electronic structure without explicitly treating the core electrons. PBEsol, as mentioned earlier, is a functional design that improves the description of solid-state properties in DFT calculations, making it suitable for studying materials such as semiconductors and insulators [6].

## Analysis and results

*Crystal Structure Properties.* The convergence test for GaP, shown in the graph, demonstrates the relationship between the plane-wave cutoff energy ( $ecutwfc$ ) and the total energy of the system. As  $ecutwfc$  increases from 20 to around 50 Ry, the total energy decreases significantly, indicating improved accuracy. Beyond 50 Ry, the total energy stabilizes, showing the minimal change with further increases in  $ecutwfc$ . This suggests that a cutoff energy of 50-60 Ry is sufficient to achieve a well-converged total energy for GaP, balancing computational efficiency with accuracy (Figure 1).

Determining the converged k-point mesh is a critical step in DFT calculations. It ensures that your computational results are accurate and that you're not using more computational resources than necessary. The process involves systematically increasing the k-point density until your results no longer change significantly with additional k-points (Figure 2).

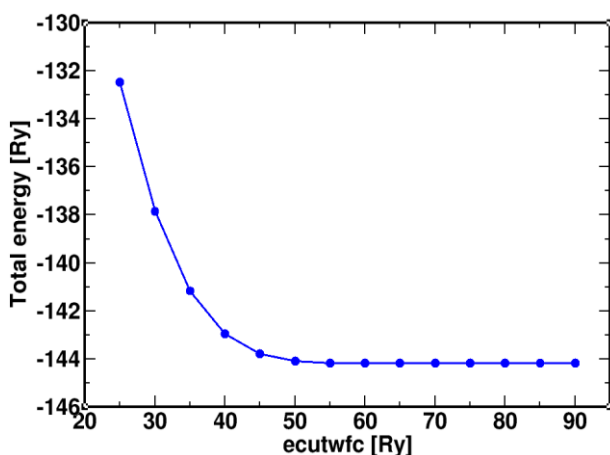

**Figure 1.** Convergence of total energy and plane waves cutoff (ecut).

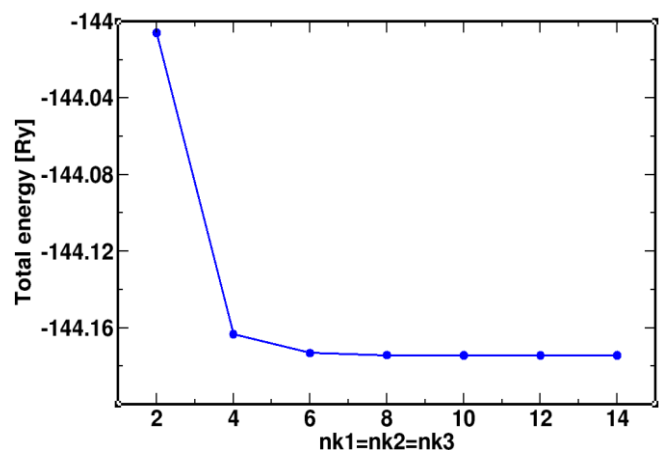

**Figure 2.** Convergence of total energy and BZ sampling (k-point).

A convergence that the properties of the material (such as total energy, electronic structure, or band gap) do not change significantly when the number of k-points is increased. This ensures that the calculation is accurate and reliable. The converged k-point for GaP crystal is  $nk1=nk2=nk3=8$ .



Gallium phosphide crystallizes in a cubic zinc blend-type structure. To determine the lattice parameter of the solid solution, we used a  $2 \times 2 \times 1$  supercell. This has 16 Ga and 16 P atoms. Out of this, we have substituted 1 Ga atom and 1 P atom with 2 Si atoms. This implies 6.25% doping.

The lattice constant of  $1 \times 1$  cell was taken to be the DFT optimized one, i.e., 5.4303 Å (exp T=0 K, 5.448 Å [7], 5.450 Å [8]) based on the graph shown in Figure 3.

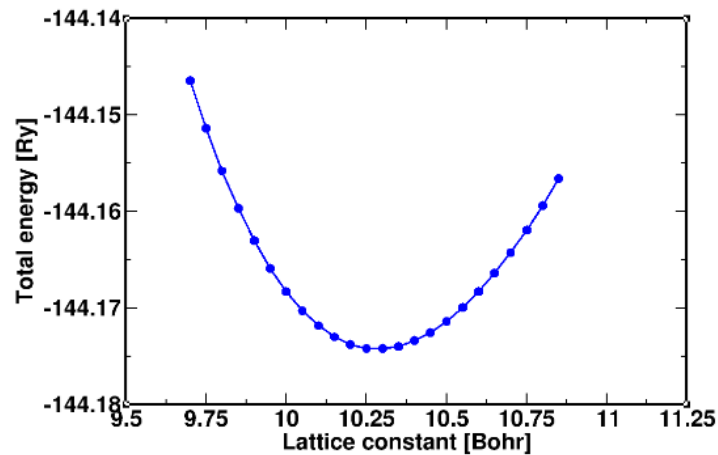

Figure 3. Optimization of total energy and lattice constant.

Then, we did a “vc-relax” calculation with the 6.25%  $\text{Si}_2$  doped  $2 \times 2 \times 1$  supercell of GaP. Figures 4 and 5 are shows the conventional unit cell of GaP and the  $2 \times 2 \times 1$  supercell for the solid solution  $(\text{Si}_2)_x(\text{GaP})_{1-x}$ .

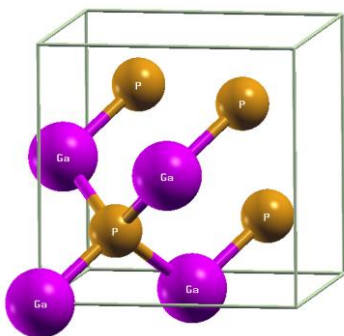

Figure 4. The optimized conventional unit cell of GaP crystal.

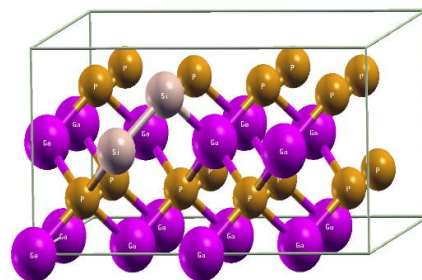
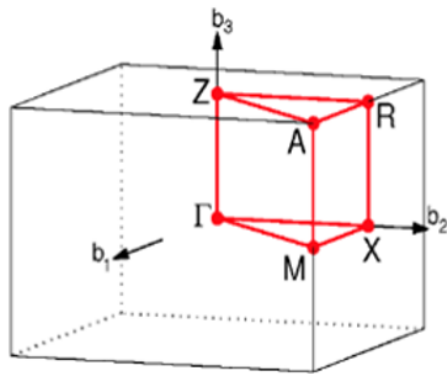

Figure 5. The relaxed crystal structure of solid solution  $(\text{Si}_2)_x(\text{GaP})_{1-x}$  ( $x=6.25\%$ ).

*Electronic properties.* The electronic properties of a material depend upon band structure (BS).

For the tetragonal Bravais lattice in real space, the k-path is given in Figure 6. Band Structure is calculated along this path  $\Gamma$ -X-M- $\Gamma$ -Z-R-A-Z. The coordinates of the high-symmetry points along the k-path are written here in  $2\pi/\text{alat}$  units. Otherwise, the coordinate of the Z point should have been within the 1<sup>st</sup> BZ and come as some fraction. We must write it in crystal coordinates so that when we choose the k-path from *xcrysden* for some different Si concentration (maybe some different supercell is used for that particular concentration), we can select the same points in terms of  $b_1$ ,  $b_2$ ,  $b_3$ .



High Symmetry Point	Coordinates in terms of $b_1, b_2, b_3$
Gamma	0.0, 0.0, 0.0
X	0.0, 0.5, 0.0
M	0.5, 0.5, 0.0
Gamma	0.0, 0.0, 0.0
Z	0.0, 0.0, 0.5
R	0.0, 0.5, 0.5
A	0.5, 0.5, 0.5
Z	0.0, 0.0, 0.5

**Figure 6.** The k-path for the tetragonal Bravais lattice in real space.

Here, the band-structure calculation was done with just 200 k-points along this k-path. The band structures of GaP and solid solution  $(\text{Si}_2)_x(\text{GaP})_{1-x}$  are illustrated in Figures 7 and 8. The figures show that they have an indirect band gap. The valence band maximum (VBM) lies at  $\Gamma$  point of high-symmetry points and the conduction band minimum (CBM) at X.

When we used the GGA-PBESol with HSE exchange correlation in our calculations, the band gap was 2.3458 eV for pristine GaP ( $E_g = 2.35$  eV [9]), and the band gap was 2.06 eV for solid solution  $(\text{Si}_2)_x(\text{GaP})_{1-x}$  ( $x=6.25\%$ ).

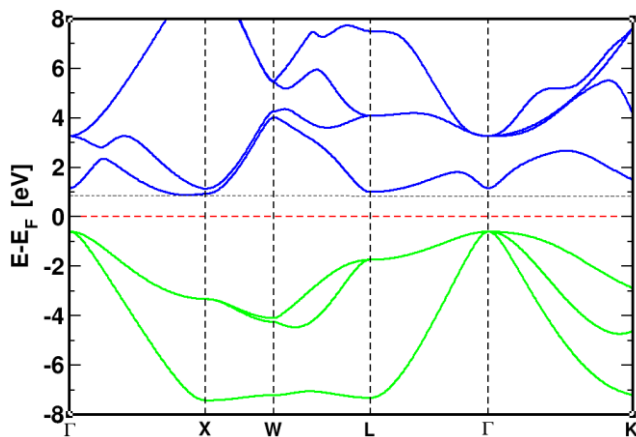

**Figure 7.** The band structure of a pristine GaP. DFT calculated band gap is 1.4814 eV.

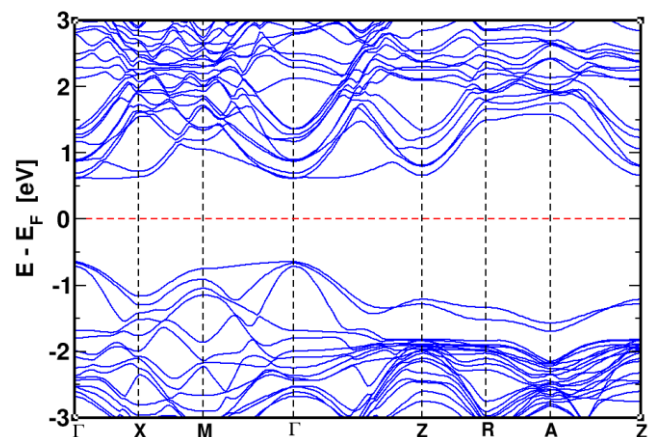

**Figure 8.** The band structure of solid solution  $(\text{Si}_2)_x(\text{GaP})_{1-x}$  ( $x=6.25\%$ ). DFT calculated band gap is 1.2548 eV.

## Conclusions

The results of the calculations showed that the lattice parameter and the band gap of GaP found as a result of calculations in this work are consistent with the calculations and experimental values of other authors. There is insufficient information in the literature about some characteristics of the solid solution  $(\text{Si}_2)_x(\text{GaP})_{1-x}$ . In this study, the band structure of the solid solution  $(\text{Si}_2)_x(\text{GaP})_{1-x}$  was calculated for the first time.



### References:

- [1] Loshkarev I.D., Vasilenko A.P., Trukhanov E.M., Kolesnikov A.V., Putyato M.A., Esin M.Yu., Petrushkov M.O. Structural state of GaP epitaxial films of different polarities on deflected Si(001) substrates. Letters to ZhTF, 2017, volume 43, issue. 4.pp. 64-71
- [2] Saidov M. S., Koshchanov E. A., Saidov A. S., Taking into account the electronic structure of ions and atoms when assessing the generalized moment of elements. Izvestiya ANU SSR. Ser. fiz-mat.nauk. 1981. No. 3. pp. 47.
- [3] Saidov A. S., Saparov D., Kholikov K. Obtaining  $(\text{Si}_2)_{1-x}(\text{GaSb})_x$  on silicon substrates by liquid-phase epitaxy. Proceedings of the international conference "Nonequilibrium processes in semiconductors and in semiconductor structures". Tashkent. 2007. pp. 130-131.
- [4] Saidov A.S. Liquid-phase epitaxy of solid solutions  $(\text{IV}_2)_{1-x}(\text{A}_3\text{B}_5)_x$ . UFZ 1993.№ 4 pp.48-51.
- [5] Saidov A.S. Liquid-phase epitaxy of metastable graded-gap solid solutions  $(\text{Si}_2)_{1-x}(\text{GaP})_x$ . DAN UzSSR, 1,14, 1990 pp. 78-81.
- [6] Saidov A. S., Usmonov Sn. N. & Rakhmonov U. Kh. Multicomponent Solid Solutions  $(\text{ZnSe})_{1-x-y}(\text{Si}_2)_x(\text{GaP})_y$ . Journal of Materials Science Research. Vol. 1, No. 2; April 2012, pp.150-156.
- [7] Nguyen Tuan Hung, Ahmad R. T.Nugraha, Riichiro Saito, Quantum Espresso Course for Solid State Physics. 2023. Jenny Stanford publishing, pp. 361
- [8] Schimka L, Harl J and Kresse G, Improved hybrid functional for solids:The HSEsol functional, J. Chem. Phys., **134**, 2011, pp. 024116(1-11)
- [9] <https://www.semiconductors.co.uk/properties-of-iiiv-semiconductors.htm#-GaP,GaAs,GaSb>.
- [10] Badal Mondal, Marcel Kröner, Thilo Hepp, and Kerstin Volz, Accurate first-principle bandgap predictions in strain-engineered ternary III-V semiconductors, Supporting Information, 2023, pp.1-13.



## MODERN PROBLEMS OF TECHNICAL SCIENCES

UDC: 62, 62-1/9, 57.04, 581.2,

### CALCULATION OF THE MAIN DESIGN PARAMETERS OF A FAN SPRAYER WITH A DOUBLE NOZZLE

**Matchanov Rafik Doschanovich**  
*Professor (DSc), Honored Worker of  
Agriculture of the Republic of  
Karakalpakistan, Corresponding  
Member of the Uzbek Academy of  
Agricultural Sciences. Institute of JV  
LLC "Agrixim" Deputy Director of  
Science and Technology.*

**Yuldashev Azamat Ismailovich**  
*Production Director, Institute of JV  
LLC "Agrixim"  
[agrixim@mail.ru](mailto:agrixim@mail.ru)*

**Annotatsiya.** O‘simliklarni kam hajmda purkash uchun qo‘shaloq nozulli ventilyator purkagichning asosiy konstruktiv parametrlarini hisoblash natijalari, shuningdek uning dala sinovlari ko‘rsatkichlari keltirilgan.

**Kalit so‘zlar:** purkagich, ventilyator, puflovchi nay, ishchi suyuqlik, mahsuldorlik, paxta.

**Аннотация.** Приведены результаты расчетов основных конструктивных параметров вентиляторного опрыскивателя с двухсопловой насадкой для малообъемного опрыскивания растений, а также показатели его полевых испытаний.

**Ключевые слова:** Опрыскиватель, вентилятор, дутьевая насадка, рабочая жидкость, производительность, хлопок.

**Abstract.** The results of calculations of the main design parameters of a fan sprayer with a double nozzle for low-volume spraying of plants, as well as the indicators of its field tests, are presented.

**Keywords:** Sprayer, fan, blowing nozzle, working fluid, productivity, cotton.

### Introduction

Leading global manufacturers of agricultural machinery produce a full range of spraying equipment, which allows timely, high-quality, and environmentally friendly protection of agricultural crops from pests and diseases [1, 2]. With widely adopted energy-saving technologies in agriculture, for the efficiency of high-quality product production, plant chemical protection is important [3, 4]. Improving the spraying quality

indicators can be achieved by controlling and regulating the application rate and reducing the loss of the preparation by switching to low-volume and ultra-low-volume spraying [5]. Low-volume spraying allows reducing the application rates of preparations by 25-30%, which can increase the productivity of units by 40% and reduce the level of environmental pollution [6, 7].

Low-volume spraying of crops with a tall stem or dense foliage (cotton, corn, potatoes) has its own features when they need to be sprayed over the entire height or when the leaves need to be covered with liquid on both sides [8]. Low-volume sprayers atomize the working fluid of high concentration into droplets 50-250  $\mu\text{m}$  in size and at rates of 10-200 l/ha for field crops and 100-500 l/ha for orchard crops [9].

The following optimal droplet sizes are recommended for attacking various targets: flying insects 10-15  $\mu\text{m}$ ; insects on the surface 30-150  $\mu\text{m}$ ; plant diseases 30-150  $\mu\text{m}$ ; weeds 100-300  $\mu\text{m}$  [10, 11].

The designs of plant protection machines are widely described in the literature [12-15]. The spraying device of a fan sprayer is called a working body consisting of liquid-atomizing nozzles and special pipelines through which the air flow from the fans passes [16]. The spraying devices should provide good quality spraying (coverage) of the treated crop, contribute to increasing the productivity of the sprayer.

The currently used fan and boom sprayers have inherent disadvantages [17], which are eliminated in the sprayer proposed by us [18].

The aim of the work is to determine the main design parameters of a fan sprayer with a double nozzle for low-volume spraying of chemical preparations on the surface of plants.

## Research Methodology

In this work, the basics of pneumatics, higher mathematics, GOSTs, and reference materials are used. Field tests of the sprayer were carried out according to GOST O‘z DSt 3203-2017 “Tests of agricultural machinery. Sprayers and dusters. Test methods”.

## Analysis and Results

The selection of the fan is carried out by the usual method [16]. In this case, it is necessary to proceed from the size of the fan, the conditions of its installation on the sprayer, the power that can be used for its drive, and the parameters that the air flow must possess. Mainly, this is the total pressure  $P$ ,  $\text{kg}/\text{m}^2$ , the productivity  $Q$ ,  $\text{m}^3/\text{s}$ , and the speed  $n$ , rpm. For specific conditions, the optimal combinations of these values are selected. The selected  $P$ ,  $Q$ , and  $n$  can be obtained with different design shapes and sizes of the fan. In our case [18], the air flow created by the fan is divided into two flows, left and right nozzles.

We set the required power for the fan drive at  $N = 22$  HP. The average speed of the air-droplet flow in the left ( $V_l$ ) and right ( $V_r$ ) nozzles was determined experimentally:



$V_l=46,7$  m/s,  $V_r=58,5$  m/s. The difference in the speed values is explained by the fact that part of the air from the left nozzle is consumed by the rear additional nozzles. The dynamic pressure in this case is determined by the formula

$$\rho_d = \frac{V_{sp}P}{2}, \quad (1)$$

where  $\rho$  - the mass density of air, equal to  $0.122$  (kg·s<sup>2</sup>)/m<sup>4</sup>.

The dynamic pressure is determined separately in the left and right nozzles.

Substituting the average velocities in the left and right nozzles into formula (1), we get:

$$P_{dl} = 134 \text{ kg/m}^2; P_{dr} = 208.7 \text{ kg/m}^2$$

We assume that the air losses in the left spraying device (nozzle) are 55%, in the right 45% of the total pressure in the nozzle.

The total pressure developed by the fan is determined by the formula

$$P_o = P_{dl} + 0.55P_{dl} + P_{dr} + 0.45P_{dr} \quad (2)$$

We obtain  $P_o=509.6$  kg/m<sup>2</sup>.

Let's establish the possible performance of the fan  $Q$  as following:

$$Q = (3600 \cdot 75 \cdot N \eta) / P_o \quad (3)$$

where  $N$  is the power for driving the fan,  $\eta = 0.55$  (fan efficiency).

Substituting the established parameters into formula (3), we get  $Q = 1.78$  m<sup>3</sup>/s.

Based on the determined parameters, we select a high-pressure centrifugal fan: Flexigum 50S.

Let's assume the fan pressure coefficient  $P_{ok}=0.9$  and calculate the circumferential speed of the impeller at the blade tips using the formula

$$V_b = \sqrt{(P_o / (\rho \cdot P_{ok}))} \quad (4)$$

We get  $V_b=68.06$  m/s. Assuming the impeller speed of the fan is  $n=2700$  rpm, we determine its outer diameter using the formula

$$d_f = (60 \cdot V_b) / (\pi \cdot n) \quad (5)$$

Substituting the established parameters into formula (5), we get  $d_f = 0.48$  m. We assume  $d_f = 0.45$  m. We determine the fan performance coefficient:

$$Q_p = Q / ((\pi d_f^2) / 4 \cdot V_b) \quad (6)$$

which is equal to 0.165.

The inner diameter of the impeller is determined by the formula:

$$d_{fn} = 1.194 d_f \sqrt{(3 \sqrt{Q_p})} \quad (7)$$

Performing the calculations, we get  $d_{fn} = 0.29$  m. Let's take  $d_f = 0.3$  m.

Let's perform a verification calculation of the power for the drive of the installed fan. For the determined parameters

$$N = (Q P_o) / 75 \eta = (1.78 \cdot 509.6) / (75 \cdot 0.55) = 21.98 \text{ hp}$$

The power we have adopted is sufficient for the effective operation of the developed sprayer. Usually, for high-pressure fans [16]:

$$d_{fn} / d_f = 0.6-0.8$$

In our case, it turned out to be 0.666.

The working flow formed by the nozzles is composed of air and a mass of the finest particles of the working fluid, atomized in it.

After leaving the nozzle, the working flow expands evenly as it moves away from the outlet. Its mass gradually increases as particles of the surrounding air are drawn into it, and the speed, on the contrary, decreases in a certain dependence on the distance. In the initial section of the flow (jet), at the exit from the nozzle, the speed of the flow core will be the highest. It is determined by the pressure inside the spraying device. Further, in the main section, the flow velocity decreases. From the axis of the flow to the boundaries of the jet, the speed also decreases and becomes zero at the boundary of the jet [16].

Let's establish the main parameters of the air flow for high-quality treatment of cotton bushes. Based on the effective width of the sprayer coverage with a double nozzle of 25m [19] and the width of the sprayer body of 1.99 m, we will set the distance from the outlet nozzle to the middle of the outermost treated bushes in height ( $x = 11.5$  m). We assume the inlet air flow velocity into the outermost treated bushes  $V_x = 8$  m/s. We specify the nozzle diameter  $d = 0.22$  m. Then the axial flow velocity  $V_o$ , coming out of the nozzle, is determined by the formula:

$$V_o = (V_x (ax/d + 0.145))/0.48 \quad (8)$$

where  $a = 0.06$  is the turbulence coefficient of the flow.

Substituting the accepted parameters into formula (8), we get  $V_o = 54.6$  m/s. Then  $V_{avg} = 0.875 \cdot 54.6 = 48$  m/s (0.875 is the coefficient for a round pipe).

To calculate the nozzle diameter, we determine the area of its outlet cross-section:

$$F = Q/V_{avg} \quad (9)$$

where  $Q = 1.78$  m<sup>3</sup>/s is the maximum fan performance.

Knowing the outlet cross-sectional area of the nozzle and the average air flow velocity, we determine the diameter of the sprayer nozzle, which is 0.212 m.

Let's clarify the value of the flow velocity entering the outermost treated bushes:

$$V_x = (0.48V_{avg})/(ax/d + 0.145) = (0.48 \cdot 48)/((0.06 \cdot 11.5)/0.212 + 0.145) = 7 \text{ m/s.}$$

The design scheme of the fan sprayer with a double nozzle is shown in Figure 1: a-rear view, b-top view.

The sprayer with a double nozzle contains a frame 1, on which a fan 2 with a duct 3 is mounted, oppositely directed left 10 and right 14 air ducts with atomizing nozzles 6 and 18, a drive connected to the power take-off shaft of the tractor. The oppositely directed air ducts 10 and 14 are offset relative to each other in the horizontal plane in the direction of movement of the unit and at the point of articulation form a housing 11, in the lower part of which inclined rear atomizing nozzles 13 and blowing nozzles 21 are fixed. At the bottom of the air ducts, there are left 4 and right 19 inclined blowing

nozzles, which are equipped with atomizing nozzles 5 and 20 and are located at an angle relative to the field surface.

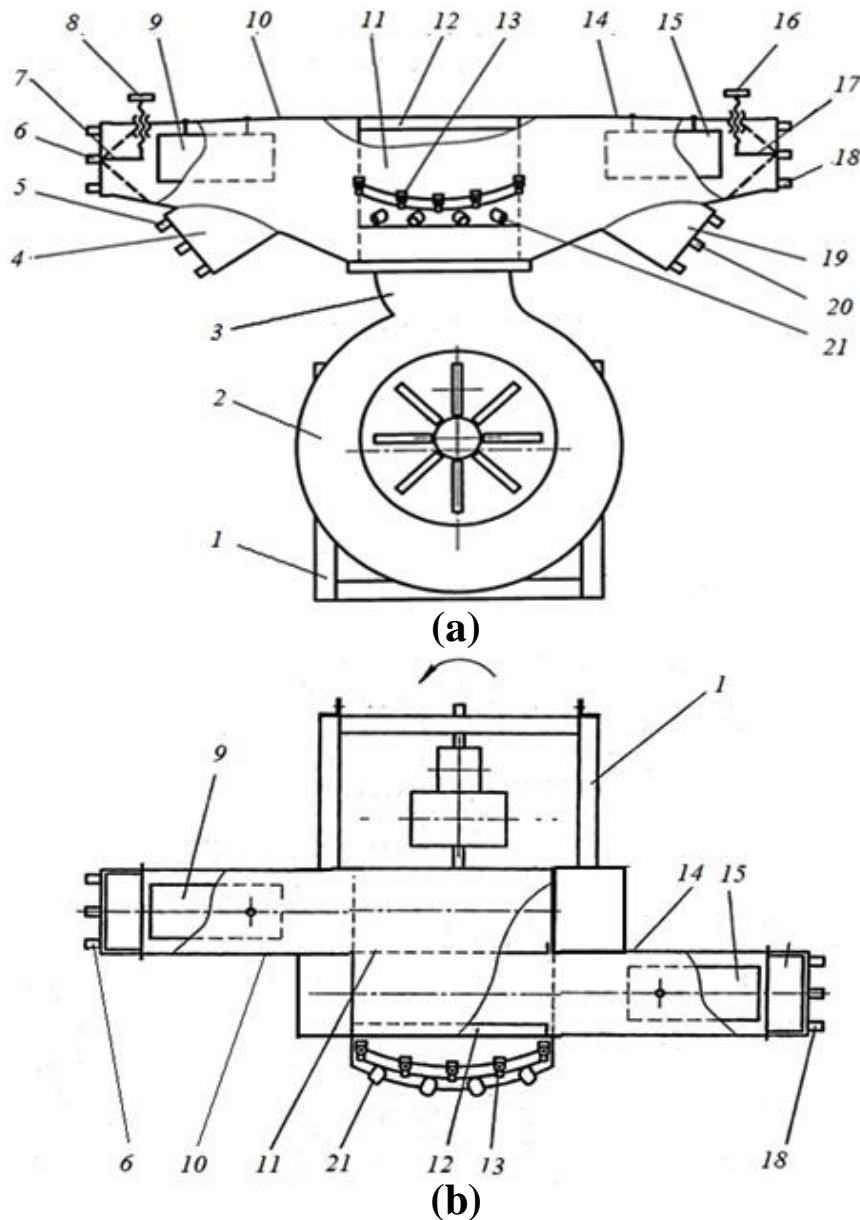

**Figure 1.** Fan sprayer with a double nozzle: (a) - rear view; (b) - top view. 1 - frame; 2 - fan; 3 - duct; 4 and 19 - inclined blowing nozzles; At the ends of the air ducts, 5, 6, 13, 18 and 20 - atomizing nozzles (sprayers); the left 7 and right 17 air flow guides are placed, the position of which is adjusted by the screw mechanisms 8 and 16. Inside the blowing air ducts, the left 9 and right 15 hollow cylinders are installed.

The prototype of the fan sprayer with a double nozzle has undergone field tests for defoliation of cotton [19]. The unit operated at a working speed of 3.9 km/h, treated cotton with a working width of 25 m. Figures 2 and 3 show, respectively, the graphs of the distribution of the quantitative deposition of the liquid by the bush tiers and the effect of the distance from the blowing outlet on the air flow velocity. At the same time, the

distribution of droplets with a coating density of more than 20 pcs/cm<sup>2</sup> - 81.5% at the top of the leaf (according to AIT at least 80%), and 57.6% at the bottom of the leaf (according to AIT at least 60%) was ensured, which corresponds to agrotechnical requirements. The median-mass diameter of the droplet traces averaged 201 μm at the top of the leaf and 239 μm at the bottom of the leaf (according to AIT not more than 125-200 μm ±10%).

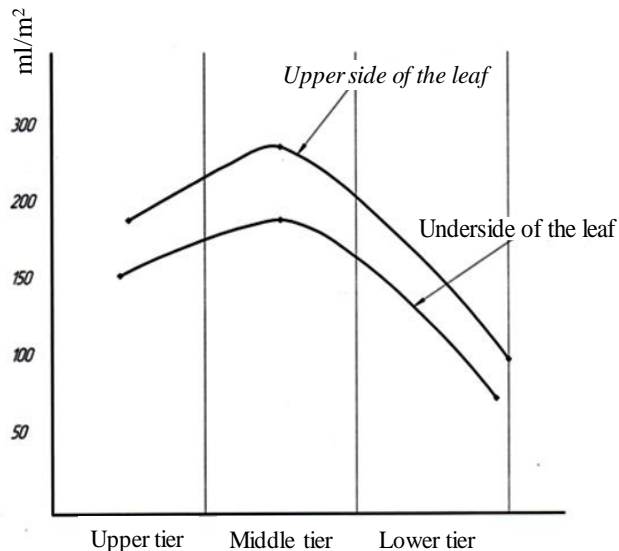

**Figure 2.** Graphs of the distribution of the quantitative deposition of the liquid by the bush tiers

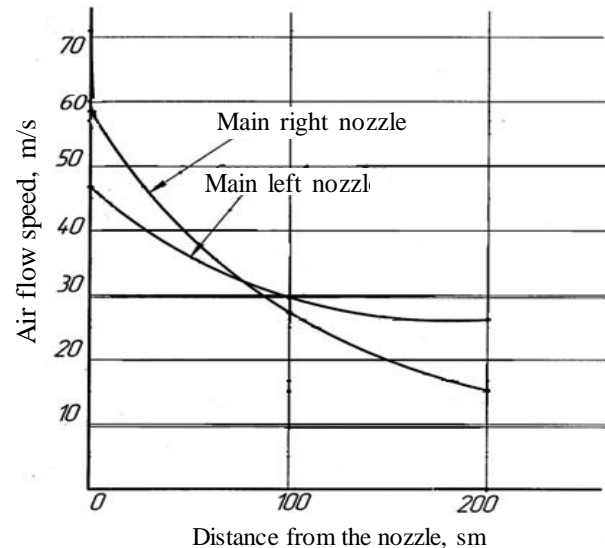

**Figure 3.** The effect of the distance from the blowing outlet on the air flow velocity

## Conclusions

The established design and technological parameters of the fan sprayer with a double nozzle allow for high-quality chemical treatment of cotton bushes in accordance with the requirements. The air flow created by the fan allows sufficiently covering the cotton bushes in height and width, including the upper and lower surfaces of the leaves, with the working fluid.

## References:

- [1] Chernoiyanov V.I., Ezhevsky A.A., Fedorenko V.F. "Global Trends in Machine and Tractor Support for Intelligent Agriculture," *Scientific Analytical Review*, Moscow, FGBNU "Rosinformagrotech", 2010, p. 292.
- [2] Chernoiyanov V.I., Ezhevsky A.A., Fedorenko V.F. "Intelligent Agricultural Machinery," Moscow, FGBNU "Rosinformagrotech", 2014, p. 124.
- [3] Milyutkin V.A., Tolpekin S.A. "Priority Design and Technological Features of Sprayers for Plant Protection in the Technical Reequipment of Agricultural Enterprises," Samara, "Niva Povolzhya", № 1(46), 2018, pp. 97-101.
- [4] Milyutkin V.A. "Integrated Use of Chemicalization Means as a Condition for Minimizing Soil Tillage," participated authors V.A. Milyutkin, A.P. Tsirulev, L.P. Tsiruleva, *Agro-Inform*, № 11-12, 2005, p. 85.



- [5] Belogorsky V.P. et al. “Improving Technologies and Technical Means of Spraying Plants,” Voronezh, “*Istoki*”, 2005, 88 p.
- [6] Kapustin V.P., Biryukova E.V. “Improving the Spraying Devices of Sprayers,” Tambov, *Bulletin of TSTU*, Volume 14, № 2, 2008, pp. 384-391.
- [7] Maslov G.G., Borisova S.M., Malashikhin N.V. “Using an Ultra-Low Volume Sprayer for Treating Orchards and Vineyards,” Krasnodar, *Scientific Journal of KubSAU*, № 149(05), 2019, pp. 1-13.
- [8] Alimuhamedov S.N. “Advanced Methods of Cotton Protection from Pests, Diseases and Weeds,” Collection of reports “Further Development of Cotton Growing in the USSR”, Moscow, “*Kolos*”, 1979, pp. 428-431.
- [9] Khalansky V.M., Gorbachev I.V. “Agricultural Machinery,” Moscow, “*Kolos*”, 2006, pp. 215-228.
- [10] Egurazdova A.S., Isaeva L.I. “Ways to Improve the Efficiency of Spraying Agricultural Crops with Pesticides,” Moscow, *VNIITEI traktoroselkmash*, 1987, pp. 24-30.
- [11] Mathews G.A. “Pest management,” *London and New York*, 1984, pp. 113-131.
- [12] “Plant Protection Mechanization,” Handbook, Moscow, VO “*Agropromizdat*”, 1992, pp. 12-15.
- [13] Kuteynikov V.K., Losev N.P. et al. “Mechanization of Work in Horticulture,” Moscow, “*Kolos*”, 1983, pp. 181-186.
- [14] “Handbook of the Mechanizer-Agrochemist,” Minsk, “*Urozhay*”, 1985, pp. 218-250.
- [15] “Handbook of Machines for Pest and Disease Control of Agricultural Crops,” Moscow, “*Kolos*”, 1967, pp. 3-20.
- [16] “Handbook of the Designer of Agricultural Machinery,” Moscow, “*Mashgaz*”, Vol. 2, 1961, p. 862.
- [17] Yuldashev A.I. “Development of Design and Justification of Parameters of a Sprayer with a Double Nozzle for Chemical Treatment of Agricultural Crops,” *Dissertation of the Doctor of Philosophy (PhD)*, Tashkent, 2022, p. 154.
- [18] Matchanov R.D., Kazarez L.A., Gussardi P., Yuldashev A.I., Artemiev V.P. Patent IAP 05658. *Sprayer*.
- [19] Research Report I-BV-2019-28 “Development of a Basic Set of Technical Means for Forming the Agrofond of a Cotton Field and One-Time Mechanical Harvesting of Raw Cotton on a Cluster Basis,” and “Development of Technology and a Combined Technical Means for Chemical Treatment, Defoliation and Desiccation with Simultaneous Electrostimulation of Cotton Plants,” Tashkent, SP LLC “*Agrikhim*”, 2021, p. 74.





UDC: 62, 66, 66.04, 635

## THE EFFECTIVENESS OF TECHNOLOGY FOR DRYING FRUITS AND VEGETABLES PASTILLA

**Kholiqov Mukhriddin Mardikulovich**

*Doctorate student, Navoi State Pedagogical  
Institute*

[muxri0770@gmail.com](mailto:muxri0770@gmail.com)

**Djuraev Khayrullo Fayziyevich**

*Professor, Bukhara Institute of Engineering  
Technology*

[xayrullo.djurayev@mail.ru](mailto:xayrullo.djurayev@mail.ru)

**Annotatsiya.** Ushbu maqolada meva va sabzavotlar pastillasini quritish texnologiyasini samaradorligi to'g'risida ma'lumotlar yoritilgan. Quritilgan mevalarning shifobaxsh xususiyatlari mavjudligi ham ko'rsatilgan. Quritilgan mahsulotlarni foydali biologik moddalari, ularni qadoqlash usullari, yurtimizda quritilgan meva sabzavotlar va dorivor o'simliklarga bo'lgan talab hamda bu talabni doimiy ravishda bartaraf etishda amalga oshirilayotgan ishlar o'rganilgan. Mahalliy mevalarni qayta ishlash usullari va uning ahamiyati to'g'risidagi ma'lumotlar ham keltirib o'tilgan. Mevalarni quritish texnologiyalar, tabiiy quritish usullari, zamonaviy-kimyoviy usulda quritish va energiya tejamkor texnik vositalar yordamida quritish texnologiyasi haqida so'z yuritiladi.

**Kalit so'zlar:** meva, sabzavot, saqlash, ombor, quritish, texnologiya, mahsulot, jarayon, xo'jalik.

**Аннотация.** В данной статье представлена информация об эффективности технологии сушки фруктовых и овощных гранул. Также было доказано, что сухофрукты обладают целебными свойствами. Изучены полезные биологические вещества сушеных продуктов, способы их упаковки, спрос на сушеные фрукты и овощи и лекарственные растения в нашей стране и проводимая работа по устранению этого спроса. Также дается информация о местных методах переработки фруктов и ее важности. Обсуждаются технологии сушки фруктов, естественные способы сушки, современная химическая сушка, а также технология сушки с использованием энергоэффективных технических средств.

**Ключевые слова:** фрукты, овощи, хранение, склад, сушка, технология, продукт, процесс, экономика.

**Abstract.** This article provides information on the efficiency of fruit and vegetable pellet drying technology. Dried fruits have also been shown to have healing properties. Useful biological substances of dried products, methods of their packaging, the demand for dried fruits and vegetables and medicinal plants in our country and the ongoing work to eliminate this demand have been studied. Information about local fruit processing methods and its importance is also given.

Fruit drying technologies, natural drying methods, modern chemical drying, and drying technology using energy-efficient technical means are discussed.

**Keywords:** *fruit, vegetable, storage, warehouse, drying, technology, product, process, economy.*

## Introduction

In the gardens and fields of our country, the peak period of ripening coincides with the summer season. In the summer season, the fruits ripen one after the other. Harvesting this ripening crop without destroying it requires great responsibility from our gardeners and entrepreneurs. Fruits that ripen in summer, such as peaches, plums, and grapes, cannot be stored for a long time. That is why the fruits that are overused are dried.

One of the most important problems of today is to ensure the food security of the population through the development and improvement of the agricultural and agrarian sector and the delivery of high-quality marketable agricultural products. In particular, creating a reserve of fruits and vegetables, drying them while maintaining their useful coefficient, and providing them with fruit vitamins necessary for human health is one of the urgent issues of today [1]. In this article, we talk about the methods and technologies of fruit and vegetable processing, and show that the effectiveness and importance of the technology of drying fruits and vegetables are today's requirements.

The climatic conditions of our republic have high temperature, low air humidity, and it is favorable for drying fruits in the sun. Sun-dried products are highly valued in terms of quality compared to artificially dried ones. In order to obtain high-quality fruit and vegetable products, it is necessary to create conditions that ensure their quick and good drying.

## Literature Review

It is known that agricultural products are grown in a certain season of the year, therefore it is impossible to solve the issue of providing the population with various products throughout the year without organizing their long-term storage and processing. As the production of agricultural products increases, it is necessary to design enterprises for their storage, modern materials, and place all the technological and technical equipment necessary for their construction. Improvement of processing of grape products based on innovative requirements requires the construction of new modern warehouses [2].

The main task of storing grapes is to preserve their physical and chemical composition, that is, their appearance, color, taste, nutritional value and other properties. For this reason, scientific research work was carried out to solve the problem of storing grapes in cold storage and organizing their processing on a correct and scientific basis to provide the population with these products throughout the year [3].

Among the foreign scientists on improving the technologies of fruit and vegetable storage, K.A. Fikiin, D.M. Barrett, L.P. Somogyi, H. Ramaswamy, M.G. Skite, S.A. Rayye, K.A. Andjell, Erdeli L., Almaty E., Sharoy T., Averin G.D., Juravskaya N.K., Kaukhcheshvili E.I. Antonov A.A., Wenger K.P., Wenger K.P., Antonov A.A. G.A. Belozarov, M.A. Dibirasulayev, V.N. Koreshkov, one of the scientists of our country Z.S. Salimov, A.A. Artikov, O.F. Safarov, H.S. Nurmuhamedov, J.M. Kurbanov, H.F.

Jorayev, Q.O. Dodayev, S.G. Zakirov, U.V. Mannonov and others conducted scientific research.

### **Research Methodology**

To dry fruits and vegetables in the sun, it is necessary to prepare specially equipped drying areas in the open. The correct selection of drying areas affects the reduction of product costs and the improvement of product quality. Drying stations are organized near fruit and vegetable plants. The level of the drying area depends on the type of fruit to be dried, the amount placed per square meter. For example, if 10 tons of products are received for drying every day and 10 kilograms per square meter are placed for drying, 10,000 square meters or drying area is required for this amount of products during the whole season.

A variety of high-quality fruits and vegetables are grown in our republic. The chemical composition of these fruits and vegetables, i.e. their sugar content and vitamin content, are much higher than the fruits and vegetables of the northern regions. Fruits and vegetables are important for the human body. The abundance of easily digestible sugars, organic acids, vitamins and minerals in them indicates how important fruits and vegetables are for the human body. We do not have the time and opportunity to store fruits and vegetables for a long time and to send them to other distant places. If there is an opportunity, fruits and vegetables can be stored in special warehouses for a maximum of 5-6 months. The quality of such stored fruits and vegetables decreases, their physical weight decreases. That is why it is important to dry fruits and vegetables. Dried products are very convenient to load - unload, store, and at the same time, these products are quality products for various expeditions and passengers.

Agricultural products, fruits and vegetables are the main part of daily life needs. Extensive reforms are being implemented in our country to constantly fill this need. Decisions, decrees and programs aimed at the development of this sector are being adopted. As a result of these large-scale and continuous reforms, great achievements and milestones are being achieved in the field of agriculture. Agricultural products grown in our country have always been famous and popular due to their naturalness, richness in vitamins, and unique taste. Therefore, the demand for fruits and vegetables grown in Uzbekistan is high in the world market.

### **Analysis and Results**

The process of dehydrating wet products using a drying agent is called drying. In this process, moisture passes from the solid phase to the gas (or steam) phase by evaporation. It is important to organize the process of drying wet fruits in the industry. First of all, dried fruits contain medicinal vitamins necessary for human health, they have more safe and useful aspects than fruits stored in refrigerators and various chemical methods. Transportation of dried products becomes cheaper, their medicinal properties are improved, they are less affected by microbes, they have a high storage capacity and require less space [4].

We will not always be able to store the fruits at the temperature for a long time and send them to other distant places. If possible, fruits can be stored in special warehouses for a maximum of 5-6 months. The quality of such stored fruits decreases, their physical weight decreases. Therefore, the process of drying them is important. The dried products

are very easy to load, transport and store, and at the same time, these products are considered to be good quality to carry on various trips. The climatic conditions of the republic have high temperature, low air humidity, and it is convenient for drying fruits in the sun. Sun-dried products are rated higher in quality than artificially dried products. In general, the importance of drying fruits and vegetables is very high.

Firstly, with the organization of high-quality drying of fruits and vegetables, it is possible to increase the production profitability of farms specializing in horticulture and vegetable growing, to increase their competitiveness and further economic development. Because organizing the drying of fruits and vegetables is one of the most inexpensive, simple and popular directions in the field of processing agricultural products [5].

Secondly, dried fruits and vegetables are sold at much higher prices both in the domestic market and in export compared to their fresh state.

Thirdly, by drying fruits and vegetables, there is an opportunity to increase their shelf life and fully satisfy the demand of the population for these products during the off-season.

Fourthly, during the summer period in the country, many fruits are spilled and die (for example, apricots, plums, etc.). The organization of drying allows to prevent these products from spilling and perishing due to rapid drying.

So, it can be seen that drying fruits and vegetables is a promising direction for farms. Organization of the process of drying fruits and vegetables in the industry is of great importance. Transportation of dried products becomes cheaper, their properties are improved, they are less susceptible to the effects of microbes, they have a high storage capacity and require less space.

Drying is done in two ways, natural and artificial. Dehydration of products in the open air is called natural drying, this process takes a long time. In the food industry, artificial methods are also used to dry products, this process is carried out in special drying devices.

Products intended for drying are divided into three types:

- solid (granular, fragmented, particulate);
- pasty;
- liquid (solutions, suspensions).

According to the method of interaction of the heat carrier with the materials being dried, drying is divided into the following types:

1) convective drying - wet product and drying agent are directly mixed with each other;

2) contact drying - there is a wall separating them between the heat carrier and the wet product;

3) radiation drying - heat is spread through infrared rays;

4) dielectric drying - the product is heated in a high-frequency current field;

5) sublimation drying the product is dehydrated under high vacuum while being frozen.

The last three methods are relatively rarely used in industry and are usually special drying methods.

## Conclusions

In conclusion, we can say that in recent years, a lot of attention has been paid to drying fruits and vegetables in our country. Since the vitamins contained in fruits and vegetables and medicinal plants are preserved by drying, it is widely used as a bioactive food modifier.

Dried fruits have many beneficial effects on the body, including:

- improves the digestive system;
- increases immunity;
- gives energy to the body;
- rich in antioxidants.

Also, the role, importance and relevance of technologies in the quality preservation of dried products is considered important. Therefore, a practical approach is more important than a scientific approach to improve the quality of products, increase energy efficiency, reduce time and labor, improve basic technological processes and devices, and master them. Dried fruits are very nutritious, high in nutrients, 100 percent natural and improve digestion, which fully shows its advantages.

## References:

- [1] Shaumarov Kh.B., Islamov S.Y. “Technology of storage and primary processing of agricultural products,” *Tashkent*, 2011.
- [2] Azizov A.SH. and et.al. “Fundamentals and equipment of design of storage warehouses and processing plants,” *Tashkent*, 2014.
- [3] Isamiddinov M. “Storage of products in a cold room: a guide/ UNODC representative office in Uzbekistan, Ministry of Foreign Economic Relations, Investments and Trade of the Republic of Uzbekistan,” T.: *Baktriya press*, 2013, p. 10.
- [4] Xoliqov M.M., Djurayev X.A., Nasirova Sh.N. “The importance of improving the drying processes of fruit and vegetable pastilles,” *Nauchniy jurnal Universum: “Texnicheskie nauki”*, № 7(100), Rossiya, pp. 34-38.
- [5] Khalikov M.M. “Efficiency improvement of drying processes of fruit and vegetable pastilles,” International scientific and practical conference on the influence of digital technologies on the development of New Uzbekistan. Kokand, - “*Innovative Development Publishing House*”, June 21, 2023, pp. 44-46.





UDC: 331, 331.4, 622.8

## FULFILLMENT OF THE REQUIREMENTS OF LEGAL-NORMAL-TECHNICAL DOCUMENTS OF LABOR PROTECTION MANAGEMENT IN PHYSICAL EDUCATION AND SPORTS

**Narziev Shovkiddin Murtozaevich**

*Head of the Department of Quality Control of Education (PhD),  
Renaissance Educational University  
[omad.uz.86@mail.ru](mailto:omad.uz.86@mail.ru)*

**Sulaymanov Sunnatilla**

*Professor (DSc), Department of Technosphere, Tashkent State Transport University*

**Annatatsiya.** Ushbu maqolada mehnatni muhofaza qilishni boshqarish tizimlarining tushunchalari va nazariy modellari, me'yoriy-huquqiy hujjatlarning muhim jihatlari va ahamiyati, baxtsiz hodisalar, sog'liqning buzilishi va ish bilan bog'liq kasalliklarning oldini olish choralari yoritilgan. Shaxsning barkamol rivojlanishida sportning ahamiyati katta. Lekin sport mashg'ulotlari davomida mehnatni muhofaza qilishni boshqarishda tizimini tashkil qilinishi sportchilar orasida baxtsiz hodisalar va kasb kasalliklari dinamikasi kamayishiga olib keladi. Bundan tashqari, mehnat muhofazasini boshqarish tizimida huquqiy-me'yoriy-texnik hujjatlari talablarini bajarilishi yuzasidan ma'lumotlar berilgan.

**Kalit so'zlar:** *sport, mehnatni muhofaza qilish, kasb kasalligi, huquqiy hujjar, mehnat sharoiti, nazorat, baholash, jismoniy tarbiya.*

**Аннотация.** В данной статье рассматриваются концепции и теоретические модели систем управления охраной труда и безопасностью, важные аспекты и значение нормативных актов, меры по предотвращению несчастных случаев, нарушений здоровья и профессиональных заболеваний. Спорт имеет огромное значение в развитии человека. Однако создание системы управления охраной труда при спортивной подготовке позволит снизить динамику несчастных случаев и профессиональных заболеваний среди спортсменов. Кроме того, дается информация о выполнении требований нормативно-технических документов в системе управления охраной труда.

**Ключевые слова:** *спорт, охрана труда, профессиональные заболевания, правовые документы, условия труда, контроль, оценка, физическое воспитание.*

**Abstract.** This article discusses concepts and theoretical models of occupational health and safety management systems, important aspects and significance of regulations, measures to prevent accidents, health problems and occupational diseases. Sport is of great importance in human development. However, the creation of a system for managing occupational safety during sports training will reduce the dynamics of accidents and occupational diseases among athletes. In

addition, information is provided on compliance with the requirements of regulatory and technical documents in the occupational safety management system.

**Keywords:** *sports, labor protection, occupational diseases, legal documents, working conditions, control, assessment, physical education.*

## **Introduction**

The development of sports in our country is a very important task, and today its solution is of particular importance. Gradually changing lifestyles, deteriorating environmental conditions, health problems, and longer health expect more physical activity from people. But along with the positive aspects, sports can cause injuries and diseases, and sometimes harm the athlete's health and life. Up to 30% of athletes are injured during sports training, and from 23 to 60% of their general health is impaired. In the labor protection management system, compliance with the requirements of legal-regulatory-technical documents, risk assessment and prevention in any work process is important in ensuring the safety of people in various conditions.

## **Literature review**

In Article 25 of the Labor Code of the Republic of Uzbekistan, it is the duty of the employer to ensure labor safety and conditions in accordance with the regulatory requirements of labor protection, to provide employees with equipment, tools, technical documents and other tools necessary for the performance of their labor obligations [1]. is determined to be.

One of the documents regulating the management system of labor protection in the Republic of Uzbekistan is the Model Regulation [2] on the organization of work on labor protection. This Regulation is used to organize work on labor protection in enterprises and organizations based on the requirements of the labor protection management system.

According to labor protection rules, sanitary and hygienic standards and regulations, as well as other laws and regulations, the training facilities and places of athletes should have natural and artificial light [3, 4], heating, ventilation systems, as well as noise absorbing and blocking devices, and in the training place sports equipment should meet ergonomic requirements [5, 6].

In the analysis of accidents and injuries occurring in the life of people, it is necessary to take into account the characteristics of the objects of the production industry, to take into account the existing methods of choosing the profession of employees [7]

## **Research Methodology**

GOST 12.0.230-2007 “Labor protection system standards” for development and implementation of labor protection management system in world experience and practice. Labor protection management system. General requirements [6]; OHSAS 18001:2007 “Regulatory documents for evaluating the organization of labor protection” [9]; GOST 12.0.230.2-2015 “Standard system of safe work. Management systems of labor protection and health in organizations. Evaluating compliance. Requirements” [10]; International standards such as ISO 45001:2018 “Occupational health and safety management systems - requirements and recommendations for use” are used [11].

Manual on occupational health and safety management systems (in Russian: Rukovodstvo po sistemam upravleniya okhranoy truda. MOT-SUOT 2001/ILO-OSH 2001) was developed by the International Labor Organization (ILO) in accordance with the tripartite universally recognized international principles of social and labor relations. This three-pronged approach provides a framework for strength, flexibility, and the development of a sustainable organizational safety culture [12].

There are various methods of risk assessment, but the model for creating an algorithm of actions in any method is approximately the same:

- to determine the object of direct research;
- characteristics of the research object in terms of its danger by studying the documents for the object;
- analysis of statistical data on accidents, fire risk, etc., for the same type of object under inspection;
- primary analysis of collected data;
- identification of all types of potential risks with the possibility of implementation in the research object;
- creating a list of potential risks for the research object.

The research method chosen for a specific object must meet the following criteria: scientific validity and logical ratio of the method and the object; complete effectiveness, that is, the ability to obtain results in the most appropriate and understandable form for the object of research; any method should be validated by inspection.

The system of labor safety standards does not exclude the validity of normative legal documents containing state requirements for labor protection, including norms and regulations approved by executive authorities within their powers. Normative and legal documents containing state requirements for labor protection, norms and rules approved by executive authorities, and standards must be interrelated.

**Table 1.** Classes of the system of labor safety standards.

<b>Groups</b>	<b>Name of group</b>
0	Organizational and methodological standards
1	Requirements, norms, standards for types of dangerous and harmful production factors
2	Standard of safety requirements for production equipment
3	Standards of safety requirements for production processes
4	Standards of requirements for protective equipment for workers
5	Standards of safety requirements for buildings and structures
6-9	Reserve

The aforementioned legal-regulatory-technical documents do not include recommendations on the system of management and organization of labor protection in physical education and sports. Therefore, it is necessary to organize work on labor protection related to the system of management and organization of labor protection in physical education and sports, the functions and tasks of management of labor protection, development of the structure of the system of management and organization of labor protection in physical education and sports.

## Analysis and Results

Occupational safety and health management system (OSHMS) - consists of basic elements such as policy, organization, planning and implementation, evaluation and improvement activities [12].

Thus, the basis of labor protection management is the principle of sequential performance of management functions:

The employer is directly responsible and responsible for the health and safety of workers in the organization, and the implementation of these obligations, in turn, is facilitated by the use of an occupational health and safety management system.

- **policy (concept):** development of a guiding idea (plan), theoretical construction of the labor safety management system in the organization;

- **organization:** organization of work on creating, applying and ensuring the labor protection system;

- **planning and implementation:** setting goals and developing processes necessary to achieve results in accordance with the organization's concept (policy) of labor protection, as well as implementation of processes for ensuring labor safety;

- **assessment (control):** inspection of labor protection processes, control and measurement of processes in them, as well as analysis of compliance with the concept (policy) of labor protection, target and planned indicators, legal documents and other requirements. Analysis results are reported;

- **improvement measures:** the management studies the results of the analysis, makes decisions on increasing the efficiency of the labor protection management system, and implements its continuous improvement.

Organizational provision of labor activities in the field of physical education and sports implies the organization of labor processes, that is, determining the physical methods used in the performance of a specific type of sport. Studying the process of physical education and sports training and determining how much time is needed for its implementation allows choosing the best methods of training, and rationally distributing training places.

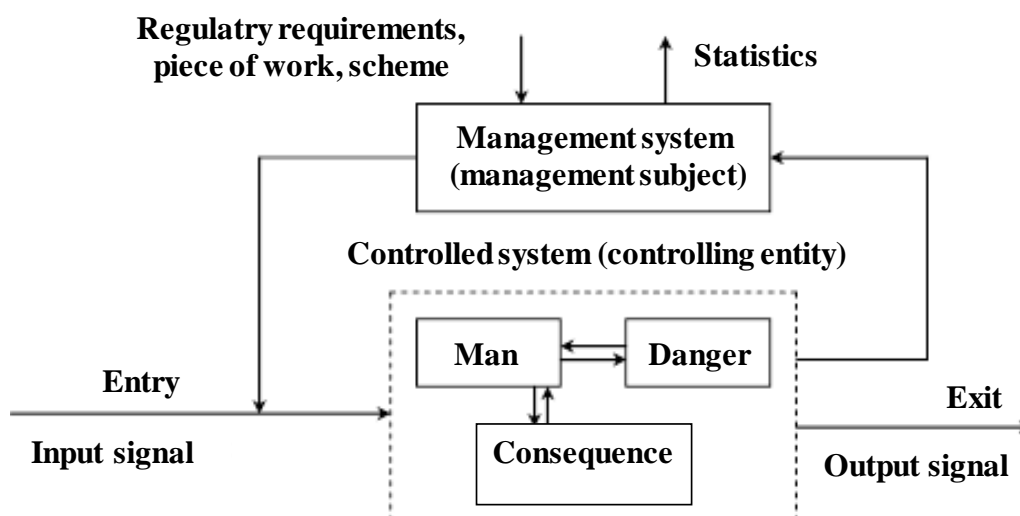

**Figure 1.** Scheme of fulfillment of requirements of legal-regulatory-technical documents in the labor protection management system.



It is impossible to ensure the sportsmen's activities without determining the labor standards. Standardization of work serves as a tool for evaluating various options for organizational support of sportsmen's activities. Due to the fact that any organizational change affects training time to a certain extent, labor standardization allows to quantify these changes and choose the most reasonable option.

The experience of many manufacturing and service enterprises shows that it is better to study, generalize, implement and disseminate best practices in three periods. These periods are:

- 1) comprehensive study of best practices;
- 2) generalization of best practice, development of organizational and technical measures for its introduction, and conducting necessary preparation and organizational work;
- 3) is to implement best practices.

One of the important directions of organizing sportsmen's activities is to comprehensively improve and modernize the conditions of physical training and sports training. Therefore, the factor of improving the conditions of the place of training and increasing the efficiency of the sportsmen's well-being is an important and urgent issue of today.

## Conclusions

1 Organizational provision of conditions for conducting physical education and sports training is based on a number of general principles of the effective activity of athletes and is largely determined by the level of improvement of sports equipment and items used in training, as well as the organizational structure of sports organizations, etc.

2. In order to take into account the organizational and technical conditions of sports training venues and the capabilities of sports organizations, sports training standardization, the elements of the sports training process, the time spent on training and the time of using equipment is required.

3. Compliance with regulatory legal documents, including state requirements for labor protection, including norms and rules approved by sports organizations within the scope of their powers, guarantees the safety of athletes.

## References:

- [1] Labor Code of the Republic of Uzbekistan, April 30, 2023.
- [2] Regarding the organization of labor protection works Model Regulation № 273, 1996.
- [3] Mandrikov V.B., Sadikova N.R. "Organization of labor protection and injury prevention in physical education classes," *Educational and methodological manual*, 2020, pp. 32-33.
- [4] Platonov V.N. "Theory of adaptation and reserves for improving the system of training athletes," *Theory and methodology of elite sports*, 2019, pp. 12-13.
- [5] Latibov Sh.M., Narziyev Sh.M. "Study and improvement of sports facilities in the microclimate conditions," *A Multidisciplinary Peer Reviewed Journal*, ISSN: 2581-4230, 2021, pp. 529-531.
- [6] Sulaymanov S., Narziyev Sh. "The Issue of Reducing Injuries by Improving the Traing of Young Boxers," *International Journal of Advanced*





*Research in Science, engineering and Technology*. ISSN: 2350-0328, Vol. 6, Issue-2, February 2019, pp. 8068-8071.

- [7] Gryzunov V.V. “The human factor as determinants of new types of possible incidents at mining enterprises,” participated authors: V.V. Gryzunov, A.M. Grishina, G.V.Kozlov, *The priorities of the world science: experiments and scientific debate Proceedings of the VII International scientific conference North Charleston. - SC, USA, 2016, pp. 178-181.*
- [8] “Labor protection system standards. Labor protection management system. General requirements,” -standard documentations: GOST 12.0.230-2007.
- [9] “Regulatory documents for evaluating the organization of labor protection works,” -standard documentations: OHSAS 18001:2007.
- [10] “Standard system of safe work. Management systems of labor protection and health in organizations. Evaluating compliance. Requirements,” -standard documentations: GOST 12.0.230.2-2015.
- [11] “Occupational health and safety management systems - requirements and recommendations for use,” -standard documentations: ISO 45001:2018.
- [12] [http://test.safe-work.ru/Bibl/BibOT/MOT/mot\\_OSH\\_01.html](http://test.safe-work.ru/Bibl/BibOT/MOT/mot_OSH_01.html)

UDC: 308, 316, 316.3

**ANALYSIS OF THE RESULTS OF SOCIOLOGICAL RESEARCH ON  
ISSUES OF IMPLEMENTING DEPUTY CONTROL OVER THE  
EXECUTION OF THE LOCAL BUDGET**

**Kasimov Abdumavlon**  
*Researcher at National  
University of Uzbekistan*  
[kasimov750@mail.ru](mailto:kasimov750@mail.ru)

**Annotatsiya.** Ushbu maqolaning maqsadi mahalliy budjet ijrosi ustidagi deputatlarning rolini va ta'sirini o'rganish, shuningdek, ularning halq bilan muloqoti va boshqaruv bilan bog'liq masalalardagi tashabbuslarni tahlil qilish bo'lib, ushbu tadqiqot bo'yicha aniq ma'lumotlar berilishidir. Tadqiqot natijalari, deputatlarning mahalliy budjet ijrosi bo'yicha qo'yilgan talablarga qanday amal qilmoqda ekanliklarini va ularning siyosiy karerasi uchun bu mavzuning ahamiyatini ko'rsatadi. Tadqiqotning asosiy natijalari deputatlarning mahalliy budjet ijrosi bo'yicha yuzaga kelgan muammolarni tezkor yechish va shaxsiy rivojlanishlarini takomillashtirish, shuningdek, deputatlarni davlat va jamiyat tomonidan qanday qo'llab-quvvatlanishini ko'rsatish uchun qo'llanilishi mumkin.

**Kalit so'zlar:** *deputatlik nazorati, natijalar tahlili, nazorat tizimining samaradorligi, mahalliy budjet, halq bilan muloqot va tashabbuslar.*

**Аннотация.** Целью данной статьи является изучение роли и обучения депутатов по вопросам исполнения местного бюджета, а также анализ их общения с общественностью и инициатив, связанных с вопросами управления, предоставление конкретной информации по данному исследованию. Результаты исследования могут показать, как депутаты соблюдают требования исполнения местного бюджета и важность этой темы для их политической карьеры. Основные результаты исследования могут быть использованы для оперативного решения проблем исполнения местного бюджета и улучшения личностного развития депутатов, а также показать, как депутаты поддерживаются государством и обществом.

**Ключевые слова:** *депутатский контроль, анализ результатов, эффективность системы контроля, местный бюджет, анализ общения с общественностью и инициатив.*

**Abstract.** The purpose of this article is to study the role and training of deputies on issues of local budget execution, as well as to analyze their communication with the public and initiatives related to management issues, providing specific information on this study. The results of the study show how deputies comply with the requirements of local budget execution and the importance of this topic for their political careers. The main results of the study can be used to quickly solve problems of local budget execution and improve the personal development of deputies, as well as show how deputies are supported by the state and society.

**Keywords:** *parliamentary control, analysis of results, effectiveness of the control system, local budget, analysis of communication with the public and initiatives.*

## **Introduction**

In the sociological research conducted on the implementation of deputy control over the implementation of local budgets in Uzbekistan, important analytical conclusions were given about the role and efficiency of deputies in this regard [1-4]. The results of the research analyzed in the article allow to identify the main trends, problems and prospects in the field of budget control at the local level.

The main results of the research include the following:

- level of awareness of deputies. On the local budget of deputy's level of knowledge and awareness, their structure, income and expenses, as well as budget execution control mechanisms understandings;

- effectiveness and efficiency of control. Activities of deputies on issues of budget control, periodicity of inspections, budget proposals and measures to improve management:

- factors affecting control effectiveness. Factors such as the political situation, the level of development of civil society, the transparency and openness of the budget process, which can affect the effectiveness of parliamentary control:

- problematic issues. Corruption, ineffectiveness of budget funds, which are the main problematic directions in the field of monitoring the implementation of the local budget such as lack of access, openness and reporting;

- development of recommendations and ways of improvement. Based on the analysis of research results, developing recommendations on measures to improve the system of deputy control over the implementation of local budgets, including measures to increase responsibility, increase transparency, and ensure the effective use of budget funds. These and other aspects of the research on the implementation of local budgets.

We hope that it will help to assess the current state of the deputy control system and determine the directions of future work on its improvement.

## **Literature Review**

*Regrettable.* In the years of sovereign development in the Republic of Uzbekistan, large-scale economic and political reforms are being carried out, which are the basis for establishing a legal state with a socially oriented market economy.

In the process of forming a legal state, great importance is attached to increasing the efficiency of the local representative bodies, regional, district and city Councils of People's Deputies [5].

And the Council elected by the population of the administrative-territorial unit, the head (governor) of the relevant executive authority of the region, district, city, as well as the departments of the territorial departments of the ministries are an important link in expressing the interests of the population. Local representative bodies participate in the development and approval of regional socio-economic development programs and control of their implementation by executive authorities in the relevant region [6-8].

## Research Methodology

Several scientific research and sociological research methods were used in the research, the main of which are the following:

- Studying documents and reports.
- Questionnaire and interview.
- Analysis of popular scientific literature.
- Comparative analysis.

## Analysis and Results

As a result of the reforms carried out in Uzbekistan during the years of independence, the private sector was formed and strengthened, the economy was diversified. The civil activity of the population acquired an organizational basis in the form of political parties, non-profit organizations (non-governmental non-profit organizations), non-governmental and non-governmental organizations. Consumers of state services (residents, entrepreneurs, institutions of civil society) are mostly local authorities during their activities as they interact with, more efficient and quality management is required for them at the local level. This creates a need to increase the quality of development and approval of normative legal documents and regional development programs by the Council.

One of the main directions of UN development assistance to the Republic of Uzbekistan is “increasing the efficiency, inclusiveness and responsibility of central and local level management”. Uzbekistan in this regard the most important work in the framework of assistance to the government of the United Nations Development Program (UNDP) was implemented at the local level by the United Nations Development Program (UNDP) on increasing the capacity of the national parliament, introducing an electronic government system and improving public administration [5].

Supporting the more effective implementation of control, representative and law-making functions of the Councils of People’s Deputies, involving civil society institutions, is an important component of the last direction is one of the parts. The article analyzes a number of important aspects considered in the sociological and financial-economic literature:

### *Forms of organization of the activity of the Council of People’s Deputies*

1. Normative-voluntary activity of Councils of People’s Deputies. According to Article 6 of the Law of the Republic of Uzbekistan “On Local State Power”, the Council of People’s Deputies as a local representative body, if the law unless otherwise provided for in the documents, decisions shall be made from the moment of their approval. All enterprises, institutions, organizations, officials and citizens located in the territory of the region, district, city must implement the decisions made within the scope of their authority [7].

Drafting of council decisions is entrusted to permanent commissions according to their activity. Three-four people from among the members of the permanent commission to prepare the draft of the Council’s decision a working group consisting of deputies will be established. Representatives of state bodies and NGOs, government employees, scientists, specialists and others may be involved in the work of the working group.

2. Transparency of the Council in the decision-making process. In accordance with the provisions of the Law “On Regulatory-Legal Documents” (Articles 28, 29) [4], regulatory-legal documents must be published in official publications. Today, most local government bodies have their own official publications. For example, “Vechniy Tashkent”/ “Tashkent Oqshomi” newspaper is a publication of the capital authorities. The newspaper “Tashkent Haqiqati” is the newspaper of the Tashkent regional government and the Council of People’s Deputies. Also, electronic versions of the texts of regulatory legal documents of ministries, state committees, agencies and local government bodies must be published on the official websites of the authorities.

However, the research showed that many legal documents are implemented without being announced in the local mass media. This situation is contrary to the current legal norms, the principles of transparency and openness of government bodies.

In order to ensure the timely announcement of the decisions of the Council, it is proposed to impose on the Commission on Regulations and Deputy Ethics the obligation to submit a report on the publication of documents approved by the Council at the beginning of each session. This provision should be strengthened in the statute on local representative bodies.

3. Quality of acts adopted by councils. People’s deputies Mechanisms for their implementation are considered in the majority decisions of the councils. There are unfilled link criteria. Also in some decisions of the Councils it is appropriate to indicate the mechanism of document execution due to the fact that they do not specify the deadlines for the execution of tasks and the persons responsible for their execution, which leads to inconsistency of the actions of local executive authorities and a decrease in responsibility. Deputies and administration participating in the development of normative-legal documents is coming In doing so, developing a model version of the decision of the Council of People's Deputies, in order to improve the skills of its employees, it is recommended to organize training sessions in areas such as “Development of normative and legal documents at the local level”, “Formation of regional programs for socio-economic development,” development etc. These steps will increase the quality of Council decisions and ensure their timely implementation.

4. Legal support of the Council’s activities. The decision of the Cabinet of Ministers of the Republic of Uzbekistan “On measures to introduce the electronic system “E-dagor” into the activities of local government bodies” defines the main tasks and functions of this service [1]. In particular, in the field of law-making and law-enforcement practice, the legal service develops and participates in the development of current and prospective programs of law-making activities of the state body, develops or participates in the development of normative legal documents on law-making, resolves issues within the competence of the state body , as well as orders, decisions and carries out expertise of other draft legal documents.

However, studies have shown that the current level of salaries of lawyers of the administrative apparatus does not support highly qualified and experienced lawyers hindering attraction. Another problem is the transport distance from the regional centers of a number of districts, which reduces the interest of potential employees. Due to the fact that the legal experts are entrusted with the preparation of draft resolutions of the



Council and the legal support of the deputies, the existing problem reduces the quality of the adopted normative legal documents [2].

In order to improve the quality of the adopted regulatory legal documents of the Council, it is proposed to revise the current salary rate of the lawyers of the administration upwards. Also, it is advisable to further improve the organization of special courses for lawyers at the Center for the Training of Lawyers under the Ministry of Justice of Uzbekistan or at the Academy of Public Administration under the President of the Republic of Uzbekistan with special attention to the process of preparation of decisions at the local level or to use the distance education portal of legal entities [3].

These measures are regulatory and legal of authorities, local executive and representative bodies serves as the basis for high-quality legal provision in the process of development, acceptance and implementation of documents.

### Conclusions

Local authorities are an important institution of state administration of the country. Through them, many regulatory and legal documents, state programs are being implemented. Effective organization of the activities of local authorities is a guarantee of the development of the whole country. In this process, representing the interests of the population, being aware of the actual problems of the region and offering them acceptable solutions, local representative bodies have a special place. Democratization of state administration in Uzbekistan during the years of independence and a number of reforms aimed at the development of civil society were implemented. In particular, to further deepen the democratic reforms in our country and needed emphasize the reforms related to the formation of civil society.

Amendments and additions have been made to the Constitution aimed at further democratization of state administration, reform of information policy, and strengthening of the activities of political parties and citizens' self-governance bodies. As a result of gradual changes, political parties, several laws were adopted. Mass media, civil society institutions have reached a new stage of development. These changes in society require a review of the system of local government authorities and the role of the Councils of People's Deputies.

### References:

- [1] Budget 2024-2026, "Economy and Finance of the Republic of Uzbekistan ministry," *Tashkent-2023*.
- [2] Budget code of the Republic of Uzbekistan. "Collection of legal documents of the Republic of Uzbekistan," 29.11.2023, № 03/23/880/0905, <https://lex.uz/acts/2304138>
- [3] Akilov A.R. "Order and procedure for holding parliamentary events," *Prakticheskoe posobie*, Tashkent: 2020, p. 38.
- [4] "Law of the Republic of Uzbekistan," ORQ-682 dated 20.04.2021. *National database of legislative information on regulatory legal documents*, 19.02.2024.
- [5] Improving activities and increasing the role of local Meetings Committee People's Deputies, *UN Analytical Report*. Tashkent-2015.



- [6] The role of editions deputies in enhancing the participation of members of local communities in the process of managing territories and resolving issues of local importance by local government bodies, Astana, p. 144.
- [7] “Budget for citizens: implementation of 2022” information publication. It was prepared within the framework of the implementation program of the joint project of the United Nations Development Program (UNDP) and the Ministry of Economy and Finance of the Republic of Uzbekistan “Financing sustainable development in Uzbekistan”.
- [8] Safaev S. “On the issue of decentralization and improvement of public administration,” *Society and Management*, 1(1), 2013, pp. 26-33.

UDC: 316, 316.6, 342.7

## UNIVERSAL METHODS OF CLASSIFICATION OF VIOLENCE AGAINST PEOPLE WITH DISABILITIES

**Ziyaeva Khalida Amonkul Kizi**

*Associate Professor of Sociology (PhD),  
Mirzo Ulugbek National University of  
Uzbekistan*

[holidaziyaeva@gmail.com](mailto:holidaziyaeva@gmail.com)

**Annotatsiya.** Jahonda aholi soning oshib borishi bilan aholining tarkibiy qismida bo‘lgan nogironligi bo‘lgan shaxslarning soni ham oshib bormoqda. Nogironligi bo‘lgan shaxslar jismoniy yoki ruhiy sabablar bilan bog‘liq ravishda atrof-muhit bilan o‘zaro munosabatga ko‘ra o‘z huquqlarini mustaqil ravishda amalga oshirish va himoya qilishda ko‘plab qiyinchiliklarga duch keladilar. Shuning uchun ham nogironligi bo‘lgan shaxslar davlat va jamiyatning alohida muhofazasiga muhtoj hisoblanadilar. Nogironligi bo‘lgan shaxslar soni aholining katta qismini tashkil etishi ham ular uchun teng huquq va imkoniyatlarni ta’minlash masalasiga ko‘proq e’tibor qaratish zarurligini ko‘rsatadi. Bunday vaziyatlar dunyo mamlakatlarining ijtimoiy jarayonlariga ta’sir ko‘rsatib, mamlakatning ichki va tashqi siyosatiga hamda ijtimoiy tartibotlarini o‘zgarishiga olib kelmoqda. Bunday jarayonlar bir tarafdin mamlakatning ijtimoiy tuzilmalar faoliyatiga ta’sir ko‘rsatayotgan bo‘lsa, ikkinchi tarafdin nogironligi bo‘lgan shaxslarning ijtimoiy himoyasiga va ularning turli zo‘ravonliklarga duch kelishiga sharoitni keltirib chiqarmoqda.

**Kalit so‘zlar:** *inson huquqlari, nogironligi bo‘lgan shaxslar, xotin-qizlar, psixologik, jismoniy, jinsiy, iqtisodiy zo‘ravonlik, kamsitish, disabilizm, eybilizm, mentalizm.*

**Аннотация.** С ростом численности населения мира увеличивается и количество людей с ограниченными возможностями в составе населения. Инвалиды сталкиваются со многими трудностями при самостоятельном осуществлении и защите своих прав в связи с взаимодействием с окружающей средой по физическим или психическим причинам. Именно



поэтому инвалиды нуждаются в особой защите государства и общества. Тот факт, что инвалиды составляют значительную часть населения, также указывает на необходимость уделять больше внимания вопросу обеспечения им равных прав и возможностей. Подобные ситуации влияют на социальные процессы стран мира и приводят к изменениям во внутренней и внешней политике и общественном порядке страны. Подобные процессы, с одной стороны, влияют на функционирование социальных структур страны, а с другой – создают условия для социальной защиты лиц с ограниченными возможностями и их подверженности различным формам насилия.

**Ключевые слова:** права человека, инвалиды, женщины, психологическое, физическое, сексуальное, экономическое насилие, дискриминация, инвалидность, эйблизм, ментализм.

**Abstract.** With the increase in the world population, the number of persons with disabilities in the composition of the population is also increasing. Persons with disabilities face many difficulties in the independent exercise and protection of their rights in relation to their interaction with the environment due to physical or mental reasons. That is why persons with disabilities need special protection of the state and society. The fact that the number of persons with disabilities constitutes a large part of the population also indicates the need to pay more attention to the issue of ensuring equal rights and opportunities for them. Such situations affect the social processes of the countries of the world and lead to changes in the country's internal and external policy and social order. Such processes, on the one hand, affect the functioning of the country's social structures, and on the other hand, create conditions for the social protection of persons with disabilities and their exposure to various forms of violence.

**Keywords:** human rights, persons with disabilities, women, psychological, physical, sexual, economic violence, discrimination, disability, ableism, mentalism.

## Introduction

According to the data published by the Population Division of the Department of Economic and Social Affairs of the United Nations Secretariat on January 1, 2024, “The world's population will reach 8 billion on November 15, 2022, and almost a third of them, i.e. 33.2%, will be the population with social needs” [1]. According to the World Health Organization, 1.3 billion people in the world have a disability, which is about one in six of the world's population. If we look at the international level from the point of view of layers and social classes, people with disabilities constitute the largest minority group [2].

In New Uzbekistan, special attention is paid to the provision of targeted social services to persons with disabilities, who are considered to be the neediest segment of the population, registered in the “Iron Register”, “Youth Register” and “Women’s Register”. Special attention is paid to ensuring the rights and legal interests of citizens with disabilities in order to further strengthen the principles of kindness, benevolence and generosity in our society. The most important thing is that this system should work in practice and people of this category should feel that they are full members of the

society, his words have become the content of systematic work on social and legal protection of persons with disabilities in our country [3].

## **Literature Review**

The views on the origin of the phenomenon of violence were given by the classical sociologist Emile Durkheim in his “Method of Sociology”. E. Durkheim in his research on the evaluation of crime, “Violence can have some positive aspects along with its negative aspects. For this reason, society should pay attention to the presence of a favorable situation or environment for committing a crime. Because it is necessary to recognize that the philosophical category prevails that without necessity, causation does not occur” [4]. Canadian sociologist Lee John Alan also expressed a similar opinion, in his opinion: Crime should exist for society as one of its important components, crime is evil and violence. “If there is no form of evil and violence in society, then people do not know the meaning and value of goodness and well-being” [5].

In our opinion, when the issue of violence in sociology is considered within the framework of social stratification, violence can be interpreted as the cause of inequality in power relations, because violence means the dominance of a strong person over a weak person. The strong rule over the weak. For this reason, a strong person is unequaled by his physical or intellectual strength.

M. Weber emphasized that violence can occur at different levels of power in society and state management. He believed that legitimate rule was based on tradition, charisma, that is, the ability of a person to appeal to the hearts of other people intellectually, spiritually, or otherwise, or on legal principles [6].

The classical sociologist Talcott Parsons also made a significant contribution to the sociological study of the relationship between violence and the cause of prosperity or unrest for the community or family. In his theory of structural-functionalism, he stated that since the family is the only source of society, this social institution is an important and basic institution for society [7]. T. Parsons also believed that individuals in all social institutions, such as the family, properly fulfill their social functions and roles as a prevention of violence.

## **Research Methodology.**

In this article, the sociological analysis of approaches to the detection of violence against persons with disabilities, using content analysis and comparative methods, allows to determine the manifestations of violence and the specific characteristics of being a victim of violence of these persons.

## **Analysis and Results**

Initially, in Western European literature on sociology and social work, disability was defined as a person who has partially or completely lost the ability to work due to war, illness or injury. The Law of the Republic of Uzbekistan “On the Rights of Persons with Disabilities” adopted on October 15, 2020 on the protection of the rights of persons with disabilities in our country [8]. The adoption and ratification of the “Convention on the Rights of Persons with Disabilities” (New York, December 13, 2006) on June 7, 2021 clearly defines the socio-legal status of persons with disabilities in Uzbekistan, allowing them to express themselves as equal members of society in all areas [9].

Article 16 of the UN Convention on the Rights of Persons with Disabilities defines persons with disabilities in countries that have ratified this convention. Taking necessary measures to prevent all forms of exploitation, violence and aggression, including providing assistance and support to persons with disabilities, their families and caregivers, taking into account age and gender characteristics, including not being exposed to forms of exploitation, violence and aggression, will take all necessary measures to introduce the ways of identifying and reporting such cases, to increase their awareness in this matter. Participating states shall ensure that services for providing protection are provided taking into account age-sex characteristics and factors of disability [10].

Persons with disabilities often need positive conditions from society in order to have equal opportunities to participate in social processes. Because of this, they are more likely to experience violence. Such discriminatory unconscious behavior towards persons with disabilities can be evaluated as the beginning of violence [11].

Among persons with disabilities, women are at the highest risk of violence. This is especially the case of sexual violence against women. For women with disabilities, the lack of knowledge about sexual life, because they do not know that actions are sexual violence, they cannot distinguish violent behavior, such a situation creates conditions for the occurrence of sexual violence. Also, the inability of women with disabilities who are sexually assaulted to resist violence further encourages sexual assault.

According to a report by the European Union Parliament on June 26, 2022, almost 80 percent of women with disabilities are victims of violence and are four times more likely to experience sexual violence against other women. Research shows cases of forced sterilization of women with disabilities, especially women with intellectual disabilities, in several European countries, as well as in Asia, Australia, Latin America, and the Middle East [12].

Violence against persons with disabilities takes many forms in the global world. In particular, “Abilism” (eng. ableism) is a specific form of discrimination against persons with disabilities, which means denying them and rejecting their individuality [13]. For example, in a restaurant, when a waiter approaches customers to take orders, if one of the customers is a person with a disability, he or she will take the order to the non-disabled person accompanying him or her, rather than the person with a disability.

Another type of violence against persons with disabilities is called “disabilism”. The term was first used in the United Kingdom as a derogatory term for people with disabilities. This term is a severe form of ableism, and dysablism refers to the violent treatment and abusive behavior towards persons with disabilities [14].

Another type of violence against persons with disabilities is “Mentalism” (eng. mentalism), which is discrimination against persons with disabilities suffering from mental illnesses. It is often found among the employees of the medical institution [15].

Another form of violence against people with disabilities is called stigmatization. “Stigma” is a word derived from (Greek - Stigma) and means label, mark. For example, calling people with disabilities such words as blind, deaf, dumb, lame, garang, esipast, psycho is called stigma. One of the most widespread stigmatizations in society is the belief that people with one or another disability are mentally ill, and the lack of treatment is always a social danger [16].



## Conclusions

In conclusion, the problems in protecting the rights of persons with disabilities are mostly related to violence. People with disabilities have the same human rights as other people, but the wrongly formed perceptions and views of people in society or the systemic problems that persist in society against people with disabilities and the limitations of physical capabilities of people with disabilities directly or indirectly discriminate against them, exclude them, as well as causes them to face violence.

## References:

- [1] The United Nations, “World Population Prospects 2024,” URL:<https://population.un.org/wpp/>
- [2] World Health Organization, “Disability,” URL:<https://www.who.int/news-room/fact-sheets/detail/disability-and-health>
- [3] Mirziyoev Shavkat Miromonovich “We will firmly continue the path of democratic reforms based on the Development Strategy of New Uzbekistan,” M 54 - Tashkent: “*Uzbekiston*” publishing house, Vol. 6, 2023, p. 257.
- [4] Durkheim E. “Method sociology,” Kyiv: *Kharkiv*, 1899, p. 73.
- [5] Lee John Aalan “Ugolovno-statistichesky uchet: strukturno-funktsionalnye zakonomernosti,” M., 1998, p. 38.
- [6] Weber M. “Agrarian history Drevnego mira,” M. Weber; pod editor D. M. Petrushevskogo; carrier E. S. Petrushevskaya. Moscow: *Izdatelstvo Yurayt*, 2024.
- [7] Parsons Tolcott Zaglavie “Sistema sovremennyx obshchestv,” Mesto izdania: Moscow, Izdatelstvo: *Aspect Press*, 1998, p. 91.
- [8] Law of the Republic of Uzbekistan “On the rights of persons with disabilities” dated 15.10.2020 № ORQ-641. URL:<https://lex.uz/docs/5049511>
- [9] Law of the Republic of Uzbekistan “On Ratification of the Convention on the Rights of Persons with Disabilities (New York, December 13, 2006)” dated 06.07.2021 № ORQ-695. URL: <https://lex.uz/docs/5447413>
- [10] UN Convention on the Rights of Persons with Disabilities. URL:<https://lex.uz/docs/5501227>
- [11] Council of Europe. “Discrimination and Intolerance,” URL:<https://www.coe.int/en/web/compass/discrimination-and-intolerance>
- [12] United Nations. “Violence against women with disabilities often goes unnoticed and unpunished,” URL:<https://news.un.org/ru/story/2012/06/1204541>
- [13] Chuksina V.V., Komissarov N.N. “Discrimination on the Basis of Disability in Labor Relations,” *Bulletin of the Baikal State University*, Vol. 25, № 1, 2015, pp.126-134.
- [14] Gregor Wolbring “Die Konvergenz der Governance von Wissenschaft und Technik mit der Governance des Ableism,” *Technikfolgenabschätzung. Theorie und Praxis*. № 2. September 2009, p. 30.
- [15] Perlin Michael L. “ADA and Persons with Mental Disabilities: Can Sanist Attitudes Be Undone?” *Journal of Law and Health* 8 (1), 1993, pp.15-45.



[16] Stigma “Prejudice and Discrimination Against People with Mental Illness,”  
URL:<https://www.psychiatry.org/patients-families/stigma-and-discrimination>

UDC: 316, 316.2, 316.3, 392,

## THEORICAL APPROACHES OF THE SOCIAL SUPPLY SYSTEM TO THE EASTERN SOCIAL THOUGHT

**Tagieva Gulsum Gafurovna**  
*Associate Professor, Department  
of Sociology and Social Affair,  
Samarkand State University  
Named after Sharof Rashidov  
[gt120886@gmail.com](mailto:gt120886@gmail.com)*

**Annotatsiya.** Ijtimoiy ta'minot masalasi sotsiologiyada fundamental muammolar sirasiga taalluqli bo'lib, uning tadqiqot tarixi uzoq o'tmishdan boshlanadi. Yaqin va O'rta Sharq mintaqasi olimlari o'z asarlarida himoya, obod va farovon jamiyat barpo etishga bag'ishlangan. Maqolada “ijtimoiy ta'minot” tushunchasi, Sharq ijtimoiy tafakkurida ijtimoiy himoya tizimlari asoslarini ishlab chiqqan buyuk mutafakkirlar Abu Nasr Forobiy va Ibn Haldunning sotsiologik qarashlari, yunon falsafasida Platon va Aristotelning asarlarida ijtimoiy siyosat nazariyasi, ijtimoiy ta'minot fenomeni haqidagi ta'limotlarining ahamiyati bugungi kun nuqtai nazaridan kelib chiqqan holda asoslab berilgan. Shuningdek, Markaziy Osiyo davlatlarida ijtimoiy ta'minot tizimini rivojlanishining zamonaviy tendensiyalari, zamonaviy ijtimoiy ta'minotning tuzilishi va uning o'zgarishiga ta'sir qiluvchi omillar, ijtimoiy ta'minot institutining shakllanishi va rivojlanishining tarixiy-sotsiologik tahlili bayon qilindi.

**Kalit so'zlari:** *Ijtimoiy ta'minot, ijtimoiy himoya, ijtimoiy ta'minotga oid ilmiy maktablar, O'zbekiston milliy sotsiologiya ilmiy maktabi.*

**Аннотация.** Проблема социальной безопасности является одной из фундаментальных проблем социологии, и история ее исследования начинается в далеком прошлом. Ученые региона Ближнего и Среднего Востока в своих работах посвящены построению безопасного, процветающего и процветающего общества. В статье рассмотрено понятие “социальная безопасность”, социологические взгляды великих мыслителей Абу Насра Фараби и Ибн Халдуна, разработавших основы систем социальной защиты в восточной социальной мысли, теория социальной политики в трудах Платона и Аристотель в греческой философии и значение их учения о явлении социального обеспечения обоснованы с сегодняшней точки зрения. Также были описаны современные тенденции развития системы социального обеспечения в странах Центральной Азии, структура современного социального обеспечения и факторы, влияющие на его изменение, проведен



историко-социологический анализ становления и развития института социального обеспечения.

**Ключевые слова:** *Социальное обеспечение, социальная защита, научные школы социального обеспечения, Национальная социологическая научная школа Узбекистана.*

**Abstract.** One of the main issues in sociology is the issue of social supply; the field's main research history dates back a long way. Building a secure, affluent, and prosperous community in the Academic District is the focus of the Near and Middle East's works. The notion of "social supply", the sociological views of the great philosophers Abu Nasr Farabi and Ibn Khaldun, the fundamental systems of social supply and the development of Eastern social thought, as well as the philosophy of social policy, the works of Plato and Aristotle. From a modern perspective, Greek philosophy and the importance of the social supply creation ideology are examined. Contemporary developments in the social supply system were also discussed. Also, the modern trends in the development of the social supply system in the Central Asian countries, the structure of modern social supply and the factors influencing its change, the historical and sociological analysis of the formation and development of the social supply institution were described.

**Keywords:** *Social welfare, social protection, social welfare scientific schools, National Sociology Scientific School of Uzbekistan.*

## Introduction

The specific aspect of scientific schools of sociology as a component of society should be taken into account while studying the social supply system. This includes their theoretical approaches. Because sociology is a discipline deeply ingrained in societal structure, sociologists analyze the major facets of life, which stand for institutional approach methodologies.

Sociological research on any social supply issue must be grounded in a fundamental theoretical framework and methodological foundations that establish fundamental approaches to the process of gathering, interpreting, and utilizing factual materials for practical ends. This is the scientific responsibility in the study of social supply. Concretization of socialization is implied by all forms of social supply, their research in all fields, social supply institutions (social insurance, benefits, pensions, social service, social assistance, etc.), and acceptance of their principles.

## Literature Review

Scientists have long been interested in the methodological basis of issues of social supply system development. If we refer to the work of the thinkers of the past, most of them have solved this problem in the most beautiful way and laid the foundation for this work. In ancient times, Pythagoras, Heraclitus, Plato, Aristotle, encyclopedic scholars of the Middle and Near East, Abu Nasr Farabi, Yusuf Khos Hajib, Ibn Khaldun, Ibn Sina, Abu Rayhan Beruni, Imam Ghazali, Alisher Navoi and many other scholars raised the human mind to the heights. They recognized man as the only intelligent being among the creatures. Therefore, in their works and treatises, many issues such as the question of faith, perfection, human life and death, destiny, peace, society, existence, and

knowledge were discussed. In particular, Abu Nasr Farabi's "Book on the Views of the People of the City of Virtuous People" describes the necessary needs of prosperity and misery [1].

In the Western world, the studies of S. V. Shishkin, V. I. Bogdanovskaya, A. K. Solovyov, N. B. Topka, Z. Zamaraeva, N. A. Volgin, V. P. Galaganov [2] and other thinkers are of great importance. Centuries separate the researches of these scientists, but they are united by the fact that they are among the first and special researches devoted to the problems of social supply and social protection. Foreign scientists M. Weber, G. Zimmel [3], E. Durkheim, O. Comte, G. Spencer, T. Parsons, B. Malinovsky studied the main forms of social life, social protection, social stratification, while Mike Piper, Andi Landis, J. Mark [4] and others regularly research the issues of social protection, including the role of social supply in the social protection of citizens. These scientists justified the need for a comprehensive scientific approach to the process of social provision.

Our nation's scientists Bekmurodov, A. Saidov, A. Umarov, A. Kakharov, A. Holbekov, A. Yuldashev, N. Aligoriev, Kh. Abduramanov, A. Begmatov, M. Ganieva, O. Ota-Mirzaev, T. Matibaev, T. Narbaeva, B. Farfiyev, Sh. Sodikova, O. Abduazimov, B. Karimov, K. Kalonov, R. Ubaydullaeva, A. Seitov, F. Parmanov regarded social supply as a crucial component of society's spiritual life [4].

In the research conducted in our country, the work done in the field of social supply is sociologically analyzed, but it is important to carry out research based on the harmony of theory and practice within the framework of the social supply system of the problem.

### **Research Methodology**

Analyzed by experts' social supply system, the methodology of sociological research, sociological analysis and evaluation of the social supply system. In this context, the four stages of the methodology used to conduct sociological research are particularly significant, and it was appropriate to divide the methodology into general scientific methodology, methodology based on particular objects, special methodology, and methods and methodologies.

In this chapter were used, sociological research methods such as systematic, historical, comparative analysis, questionnaire survey, expert survey, document analysis, general scientific and empirical methods based on sociological theories. Various scientific approaches to social supply, research methodologies and principles, and ways to integrate the information and results into society's daily activities were all made possible by the application of these methods. The governmental system of social supply, material assistance, and social services for the aged and disabled people, as well as for families with children, is crucial for the working population in this respect, as well as for the elderly and those who are disabled permanently or temporarily, providing a low-income family and creating a reliable basis for life, made it possible to justify it through sociological methods. When the social supply system was assessed by experts, it was sociologically justified that it is possible to use practical experiences in the reform of the social supply system of Uzbekistan, taking into account different social, economic and demographic conditions, based on the experiences of foreign countries in the formation of social supply systems.

## Analysis and Results

In this article, we studied the Eastern and Uzbek national scientific schools of sociology related to social security.

In this table, we consider the representatives of the scientific school of sociology, the periods in which they lived and created, and the theories about the development of social security put forward by these scientific schools.

**Table 1.** The periodic representatives of the scientific school of sociology.

<b>№</b>	<b>Scientific schools</b>	<b>Representatives of the scientific school</b>	<b>Years</b>	<b>Previous theories</b>
<b>1</b>	Eastern scientific school of sociology	Pharoah, Ibn Khaldun, Beruni, Ibn Sina Al-Bukhari Bahauddin Naqshbandi Alisher Navoi	873- 1501	Dividing people into groups based on different characteristics: giving great importance to people's natural characteristics, abilities, first of all intellectual ability and knowledge and skills acquired in the process of learning sciences and life experience, not based on religious sect, nationality, race, mutual aid, wise chief, equality; stages of bidava (primitiveness) and khidara (civilization) in the development of society; correct division of labor; taking into account the human factor; division into layers, assessment depending on the client; to be kind to orphans; to be kind to the weak; mind and thinking.
<b>2.</b>	National School of Sociology of Uzbekistan	M.Bekmurodov, A.Kahharov A.Kholbekov, A.Umarov, T.Matiboev, Sh.Sodikova, O.Abdumuzimov, B.Farfiev	1992 2022	Emergence, escapism the science of foresight, the high quality of a person is mainly defined by his independent thinking, work activity and lifestyle; that a person is connected not only with his physical and spiritual qualities, but also with his lifestyle and material well-being; the harmony of the democratic development of the society with spiritual and moral values is derived from the virtues, oriental thinking and lifestyle of our people; change the worldview of the population by increasing the culture of education; social justice; that it is necessary to implement modern mechanisms of state social support, social protection and medical and social assistance for the elderly and persons with disabilities, as well as in the experience of Uzbekistan, spiritual and moral value and our traditions are of priority in the issue of social protection ownership

While studying sociological scientific schools related to social provision, first of all it is permissible to recognize the Eastern Sociological Scientific School. In this regard, in the royal works of Farabi, Ibn Khaldun, Beruni, Ibn Sina, al-Bukhari, Bahauddin Naqshbandi, Alisher Nawai, people are divided into groups based on different characteristics: people are not based on their religious sect, nationality, race, but on their natural characteristics, abilities, first of all intellectual giving great importance to talent



and the knowledge and skills acquired in the process of learning sciences, gaining life experience, mutual support, a wise boss, equality (Farobi); stages of bidawa (primitiveness) and khidara (civilization) in the development of society (Ibn Khaldun); proper division of labor (Beruni); consideration of the human factor, division into layers, assessment depending on the client (Ibn Sino); to be kind to orphans (Bukhari); to be merciful to the weak (Naqshbandi); intelligence and thinking (Navoi) put forward theories.

According to Ibn Sina, “...in any society, disabled people, that is, old people without breadwinners, orphans, and soldiers who do not directly participate in production, and guards are provided by the state. The funds spent on them are covered by taxes on the real estate and income of citizens, fines collected from criminals and lawbreakers-thieves, heavy gamblers and other categories of people” [6]. In this regard, Al-Bukhari said that “strengthening human virtues such as patting the head of orphans, finding out about the condition of the elderly, extending a helping hand to the wounded and widows in need of help, and visiting relatives is the highest form of humanitarianism” [7]. These hadiths are important for the development of our spirituality and the education of mature young people. In this regard, many examples are given in the works of the great scholars of the East, in which the ideas and theories aimed at further improving the social security issues on the basis of the issues of social protection of the population and raising this system to a new level in accordance with the requirements of the time are put forward.

In their studies, the social state and society have been focusing on the problems of supply and social service.

In the new Uzbek society, the concept of “social supply” entered the consumption of scientists and professional practice as a general direction of state policy. The concept of social state is of particular importance in the analysis of the concept of “social supply” as a theoretical model in national sociology. In this concept, social security provides employment of citizens, protection from unemployment, as well as measures to reduce poverty; everyone has the right to receive a fair wage in an amount not lower than the minimum wage; everyone has the right to receive social security in case of old age, loss of working capacity, unemployment, loss of a breadwinner; that the amounts of pensions, allowances and social assistance cannot be less than the minimum consumption costs, that taxes and fees are fair and do not prevent citizens from exercising their constitutional rights; everyone should have a home; the state creates social, economic, legal and other conditions for the full development of the family; free provision of a guaranteed amount of medical care to citizens; the procedure for providing housing to socially needy categories of the population is determined by law.

***The founder of the National School of Sociology, Doctor of Sociology, Professor M. Bekmurodov*** puts forward the theory of emergence in implementing the idea of social development. “Emergency is the changes that are taking place, the emerging social communities, worldviews, directions of social thought represent spiritual and mental conditions in the society, and the scientist should be introduced as an object and subject of national sociology.” puts forward the theory of “escapism” (“escape” in English means to escape, to move away). Professor M. Bekmurodov aims to achieve optimal solutions to the issue of social development, to ensure the activity of the society, to ensure the implementation of the processes of improvement defined in the “Strategy of Actions” and

“Strategy of Development” in various social structures in every person’s section, on the basis of a clear plan, “road map” “proposes the need to develop, draw up individual development plans, help children form clear goals from a young age, strengthen the culture of reading on a horizontal basis” [8]. In addition, the scientist emphasized the importance of clairvoyance in the social development of the society and said: “through clairvoyance, it is possible to notice the joy and sadness of other people from a small sign, from their appearance, behavior, behavior, facial expressions, to their mental state. can understand the changes correctly” [9].

According to Doctor of Sociology, Professor A. Kholbekov: “Social state is a state responsible for the social condition of citizens. In this sense, the social state relies on effective social policy in practice” [10]. In this case, it is appropriate to proceed from the definition of the concept of social policy. In sociology, social policy reflects the interaction of different classes, strata, socio-demographic, socio-professional community (family, nation, city, village, regional population, etc.) and social groups in order to ensure a decent standard of living ( N. Volgin [11]. State institutions, employers, trade unions and other socio-political structures form the social strategy of the state in order to realize the opportunities and satisfy the needs of citizens, taking into account the opinion of the public. It is based on making effective decisions and supporting them in improving the standard and quality of life of citizens. In this regard, Professor A. Kholbekov stated: “The high quality of a person is mainly determined by his independent thinking, work activity and lifestyle. Therefore, this quality of a person is related not only to his physical and spiritual qualities, but also to the material well-being of his lifestyle. At the same time, it is appropriate that the harmony of the democratic development of the society with spiritual and moral values should be derived from the virtues of our people, oriental way of thinking and lifestyle” [12]. Accordingly, social policy is one of the top goals of state policy in our nation, with social protection and the social supply system serving as essential parts of state social policy, a distinct aspect of social support, and a practical means of providing for everyone in need. It is recognized as a social value since it is a set of policies and initiatives meant to help while considering the needs of the people.

Doctor of Sociology, Professor A. Umarov, focusing on the issues of social service and social supply system, emphasizes that “it is necessary to change the worldview of the population by increasing the culture of tolerance” [13]. In this regard, the scientist studied the issues of positive impact of education on the natural environment and all aspects of social life from the point of view of sociology. Special attention is paid to the fact that no person belonging to the needy stratum of the population is neglected. Because of this, our society's social landscape is drastically shifting, effective management is becoming more and more effective, and most significantly, people's confidence in their future, their work, their destiny, and life itself is growing.

A completely new and unique social security system for solving social problems has been created in our country. These are the “temir daftar (iron notebook)”, “women’s notebook”, “youth notebook”, “mahallabay” and “household” working methods introduced in this new system. In this case, the main focus in the implementation of systematic measures aimed at providing direct, objective financial support to needy citizens is not to give subsidies to the poor, but to earn them income. aimed at creating the necessary conditions and opportunities.

These approaches clearly represent the dominant role of social supply in the celebration of the principles of justice in society. As Doctor of Sociology, Professor T. B. Matibaev described: “Social justice is a special “nerve fiber” of society, and it is this nervous system that expresses people’s social mood” [14]. After all, social justice is the mutual compatibility of positive contributions of a person to society (work, service), as well as negative effects (crime, rewards, awards) and prohibition-punitive factors (punishments, fines). We consider the methodological importance of social supply as a whole system within the systematized and ordered social function of the state. Its following components are distinguished: a) object and subject relationship in social supply; b) limits of social supply as a system; c) interaction of the social supply system with other directions and the environment in the framework of state policy.

One of our people’s old principles is honoring and valuing the elderly and giving them attention. Additionally, in our nation, full support for the elderly, social protection for senior generation representatives, heightened attention and care, better living conditions, ensuring that they lead active and meaningful lives, and making the most of their wealth of life experience as a social resource are all vital.

Large-scale works are being carried out on the formation of an effective system of honoring and respecting the elderly. In this regard, Doctor of Sociology, Professor Sh. M. Sodikova believes that, today, social protection has a specific goal and is directed to its owner, as well as a special approach to different layers of the population, implies a unique feature of the social protection system. In particular, in this process, special attention is paid to further improving the quality of life of the population, including social protection of the elderly and improving the standard of living. Based on the moral traditions and humane principles of always showing respect to the representatives of the elderly generation of our people, the elderly are taken under state protection in our country [15]. The scientist highlights the necessity of putting into practice contemporary state social support, social protection, and medical and social assistance programs for the elderly and disabled in this regard. The scientist also highlights the significance of spiritual and moral values, as well as our traditions, in the context of Uzbekistan’s social protection experience. To put it another way, everything necessary for senior citizens to live respectable lives is being established in our nation. Noble objectives like enhancing social security, improving the quality of life for the aged, and promoting peace and quiet are essentially at the center of these reforms.

In a word, in our country, all conditions are being created for elderly people to lead a decent life. At the core of such reforms are, first of all, noble goals such as further improvement of social security, making the life of the elderly prosperous and prosperous, and strengthening peace and tranquility. The social security system is to identify the needy category, to determine exactly what kind of help they need, and to provide individual social assistance and services to each of those in need.

The head of our state emphasized the need to radically reform this system, to ensure the targeting and effectiveness of social assistance. “It is impossible to work together in this field. Every family and human fate should be approached individually and professionally. If social service is implemented correctly, needy citizens will find their place in society” [16], said Shavkat Mirziyoev. In social supply, targeted social services

and assistance were provided to people based on their needs. Therefore, human personality is respected and integrated into society.

Social supply as an effective mechanism for the implementation of state social policy, social, legal and economic principles aimed at comprehensively increasing people's well-being, people's living standards, creating new jobs, sources of income, eliminating poverty, embodies methods, mechanisms and reserves.

## Conclusions

Having studied the views and theories of social security of scientific schools of sociology above, we can conclude that the task of creating a system of social protection of the population is carried out by a state that has reached a certain stage of socio-economic development and realizes its importance for the normal functioning of society is increased. A state that provides its citizens and persons legally present in its territory with a decent standard of living and free development is called social. In this regard, President Sh. Mirziyoev, in his speech dedicated to the 29<sup>th</sup> anniversary of the adoption of the Constitution of the Republic of Uzbekistan on December 7, 2021, said, "Nowadays, Uzbekistan is boldly moving towards building a social state and a just society. Therefore, the time has come to seal the principle that "New Uzbekistan is a social state" as a constitutional provision" [17]. The welfare state creates a social supply system, participates in the financing of pensions, allowances, compensations, medical and other social services. We believe that our people should deeply study the concept of the social state and know and follow the basic socio-economic rights of a person, which are established in the Republic of Uzbekistan.

## References:

- [1] Abu Nasr Forobiy "Fozil odamlar shahri," T.: *Abdulla Qodiriy nomidagi xalq merosi nashriyoti*, 1993, p. 162.
- [2] Shishkin S.V. "Sotsialnoe obespechenie ekonomicheskix reform," M.: 2002, p. 572; Bogdanovskaya V.I. "Rol Universiteta tretogo vozrasta v sotsialnoy rabote s pojilimi lyudmi," (Aspirantura, Bakalavriat, Magistratura), Monografiya, M.: 2021, p. 56; Solovyov A.K. "Pensionnie prava zastraxovannix lis: problemi formirovaniya i riski realizatsii," M.: 2020, p. 327; Topka N.B. "Sotsialnaya rabota s invalidami," (Bakalavriat), Uchebnoe posobie, M.: 2021, p. 400; Zamaraeva Z. "Sotsialnaya zashita i sotsialnoe obslujivanie naseleniya," M.: 2017, p. 175; Volgin N.A. "Osnovi sotsialnogo gosudarstva," M.: 2019, p. 421; Galaganov V.P. "Pravo sotsialnogo obespecheniya," Praktikum. (SPO). Uchebnoe posobie, M.: 2021, p. 153.
- [3] Zimmel G. "Sotsialnaya differentsiatsiya. Sotsiologicheskie i psixologicheskie issledovaniya," G. Zimmel avtor iz. per. s nem. N.N. Bokach, I. Ilina, Moskva, Berlin, *Direct-Media*, 2014, p. 233.
- [4] Mike Payper "Social Supply Made Simple," 2017, p. 130; Devin Carroll "Social Supply Basics: 9 Essentials That Everyone Should Know," *Paperback*, April 5, 2018, p. 108; Andy Landis "Social Supply: The Inside Story, 2018 Silver Anniversary Edition," *Paperback*, January 10, 2018, p. 308; Mark J. Orr CFP



- “Social Supply Income Planning: The Baby Boomer's 2021 Guide to Maximize Your Retirement Benefits,” *Paperback*, October 2, 2013, p. 129.
- [5] Bekmurodov M.B. “Ijtimoiy rivojlanishning sub’ektiv omillari,” *Respublika ilmiy-amaliy konferensiya materiallari*. Samarqand, 2021, pp.14-17; Xolbekov A.J. “O‘zbekistonda jamiyatning demokratlashuvi jarayonida ijtimoiy adolatni amalga oshirish muammolari (siyosiy-sotsiologik tahlil),” Toshkent: *O‘RPHDJQA*, 2001, p. 32; Matibayev T. “O‘zbekistonni rivojlantirish strategiyasi,” *Fuqarolik jamiyati: korrupsiya – ijtimoiy xavf*, Toshkent: *Bilim va intellektual salohiyat*, 2019, p. 69; Sodiqova Sh. “Jamiyatni modernizatsiyalash jarayonida keksalarni ijtimoiy himoyalashning sotsiologik tahlili,” *Doktorlik dissertatsiyasi avtoreferati*. Toshkent, 2016 yil.
- [6] Shayx al Ard “Ibn Sino falsafasiga kirish,” *Bayrut*, 1967, p. 486 (arab tilida).
- [7] “Islom nuri,” 1993, issue 67, p. 1.
- [8] Bekmurodov M.B. “Ijtimoiy rivojlanishning sub’ektiv omillari,” *Respublika ilmiy-amaliy konferensiya materiallari*, Samarqand, 2021, pp.14-17.
- [9] Bekmurodov M.B. “Farosat ilmiy,” *G‘afur G‘ulom nomidagi nashriyot-matbaa ijodiy uyi*, Toshkent, 2022, p.12.
- [10] Xolbekov A.J. “O‘zbekistonda jamiyatning demokratlashuvi jarayonida ijtimoiy adolatni amalga oshirish muammolari (siyosiy-sotsiologik tahlil),” Toshkent: *O‘RPHDJQA*, 2001, p. 32.
- [11] Volgin N. “Sotsialnaya politika,” Moskva: *RAGS*, 2005, p. 537.  
Xolbekov A., Nazarqosimov S., Berdiev B., Ergasheva M. “O‘zbekistonda ijtimoiy hayot transformatsiyasi,” Toshkent, “*KALEON PRESS*”, 2021, p. 57.
- [13] Umarov A.O. “Ijtimoiy-madaniy taraqqiyotni ta’minlash va komil inson shaxsini shakllantirishda mutolaaning roli,” Sos. fan. dokt. dis.... – Toshkent: *O‘zMU*, 2005.
- [14] Matibayev T. “O‘zbekistonni rivojlantirish strategiyasi,” *Fuqarolik jamiyati: korrupsiya – ijtimoiy xavf*, Toshkent: *Bilim va intellektual salohiyat*, 2019, p. 69.
- [15] Sodiqova Sh. Jamiyatni modernizatsiyalash jarayonida keksalarni ijtimoiy himoyalashning sotsiologik tahlili,” *Doktorlik dissertatsiyasi avtoreferati*, Toshkent, 2016 yil.
- [16] Shavkat Mirziyoev raisligida 20 fevral kuni “Ijtimoiy himoya sohasidagi ustuvor vazifalar muhokamasi” yuzasidan videosektor yig‘ilishi 20.02.2024y.
- [17] Mirziyoev Sh. “O‘zbekiston Respublikasi Konstitutsiyasi qabul qilinganining 29 yilligiga bag‘ishlangan nutqi” 2021 yil 7 dekabr.



**ACTUAL PROBLEMS IN MODERN ART AND ARCHITECTURE**

UDC: 78, 78.07, 780.7

**DARVESH ALI CHANGI'S OPINIONS ABOUT COMPOSERS****Dadaev Akhmatjon Shakarimovich***Associate Professor, Department of  
"National Singing", State Institute of  
Art and Culture of Uzbekistan*[dadayev@mail.ru](mailto:dadayev@mail.ru)

**Annotatsiya.** O'zbek mumtoz musiqasi qadimdan musiqa ilmi bilimdonlari, bastakorlarining ijodiy faoliyatlari tufayli boyigan. Bugungi kunga qadar yetib kelgan maqomlarimiz, mumtoz asarlarimiz ana shu bastakorlarning ishlari samarasidir. Bir qancha qadimiy qo'lyozmalarda musiqa olamida ijod qilgan musiqachilar qatorida bastakorlar ham tilga olingan. Xuddi shunday, Darvesh Ali Changiyning "Musiqiy risolasi"da ham iste'dodli insonlar qatorida, 16-17 asrlarda yashagan, bastakorlarning faoliyati tilga olangan. Ushbu maqolada Changiyning risolasida keltirilgan bir nechta bastakorlar va ular yaratgan asarlar haqida so'z yuritiladi.

**Kalit so'zlar:** *musiqiy risola, Darvesh Ali Changiy, bastakor, peshrav, saqil, naqsh, amal, parda, ilmi musiqiy, musiqa, asar, tovush.*

**Аннотация.** Узбекская классическая музыка обогатилась в древние времена благодаря творческой деятельности знатоков музыки и композиторов. Наш маком и классические произведения, дошедшие до наших дней, являются результатом творчества этих композиторов. Во многих древних рукописях среди музыкантов, работавших в мире музыки, упоминались и композиторы. Точно так же в "Музыкальном трактате" Дарвеш Али Чанги, среди талантливых людей, живших в 16-17 веках, приведена деятельность композиторов. В этой статье речь идёт о нескольких композиторах и их музыкальных произведениях, которые представлены в трактате Чанги.

**Ключевые слова:** *музыкальный трактат, Дарвеш Али Чанги, композитор, пешрав, сакил, нақиш, амал, нота, наука о музыке, музыка, произведение, звук.*

**Abstract.** Uzbek classical music was enriched in ancient times thanks to the creative activity of music connoisseurs and composers. Our national music direction called "maqam" and the classical works that have come down to our days are the result of the work of these composers. In many ancient manuscripts, composers were mentioned among the musicians who worked in the world of music. Similarly, in the "Musical treatise" by Darvesh Ali Changi, among the talented people who lived in the 16th and 17th centuries, the activity of composers is given. This article contains information about several composers and their musical works, which are presented in the treatise of Changi.

**Keywords:** *musical treatise, Darvesh Ali Changi, composer, peshrav, saqil, naqsh, amal, parda, science of music, music, work, sound.*

## Introduction

The peoples who lived in Central Asia, considered one of the oldest centers of culture, made a great contribution to world culture and science. Special recognition should be given to his scientific and practical work on the development of the field of music culture. Musical treatises that have survived to this day testify to how deeply Eastern thinkers studied the science of music. Many scholars such as Abu Nasr Farabi, Ibn Sina, Khorezmi, Darvesh Ali Changi, Abdurrahman Jami, Zaynuluddin Hosseini, etc., have scientific works on music theory, which are famous all over the world.

## Literature review

Darvesh Ali Changi's "Musical treatise" ("Risolai musiqiy") has served as the most important scientific source for musicologists and artists for several centuries. Today, a copy of this work is kept at the Institute of Oriental Studies of the Academy of Sciences of Uzbekistan (inv. №. 449, 468). This work is of great scientific importance and is considered the main source of the musical environment and culture of the XVI-XVII centuries. A.A. Semenov's treatise "Central Asian treatise of music of Darvesh Ali Changi (XVII century)" covers the analysis of this work [1]. Also, many researches have been conducted on Darvesh Ali Changi's "Musical treatise". For example, B.H. Boltaev's "Theoretical principles of spatial (cosmological) constellations of the 12<sup>th</sup> position in Darvesh Ali Changi and his contemporaries" [2], M.Z. Normurodova's "Creation of late medieval composers, figures of composers in Darvesh Ali Changi's "Musical treatise" [3], O.A. Khudoynazarova's interpretation of "Our favorite musical instruments in the eyes of ancestors" [4], U.Z. Imamov's "Pedagogical importance of studying classical musical heritage in music education" are among them [5].

## Research Methodology

The manuscript is written in Persian and consists of 12 chapters. Darvesh Ali Changi made good use of the information provided in the treatises of Abdurrahman Jami and Kavkabi when writing it. At the same time, he also received information from the works of music experts such as Hossein Ohun, Zaytun Gijjaki, Imam Kuli Udi, and described them in his treatise.

Darvesh Ali Changi's "Musical treatise", he covered the musical life of Central Asia in the 16<sup>th</sup> -17<sup>th</sup> centuries, the art of composition, musical instruments, music theory and performance issues. In general, this work can be called a very bright historical source. The author himself was a composer, creating melodies in the form of naqsh, amal, savt and peshrav, and he dedicated the 9<sup>th</sup> chapter of his treatise to music composers and talented people. That is, the activities and works of famous composers who lived and created in the XVI-XVII centuries were touched upon here.

## Analysis and Results

Chapter 9 of the treatise begins with information about teacher Zaytun Gijjaki. Darvesh Ali Changi describes him first of all as a very talented performer [1]. He says that any listener who hears his performance on the "g'ijjak" instrument will experience different emotions. Zaytun Gijjaki created several peshravs for different melodies called maqam. Especially, the peshrav, created by the method of saqil, on the melodies of maqam of Hosseini, increases the admiration of the audience. As the most skilled artist

and musician, Zaytun Gijjaki was invited to the palace of Ahmad Khan (1524-1576), who ruled Gilan. Khan Ahmad Gilani, despite being a governor, also gained fame as a scholar who deeply studied the science of music. In addition, he charmed everyone with his unique performances on the ‘ud’ instrument. A number of peshravs created by Khan Ahmed Gilani were also famous in the country. His “Isfakhan” peshrav, created with the unique method of muhammas on the melodies of panjgah, is considered one of the most famous peshravs. It turned out that the khan liked to study music rather than being a ruler and became a student of Zaytun Gijjaki [1].

Darvesh Ali Changi recognizes Maulana Husayn Akhund, a thinker and scientist recognized as the Plato of that time, as a skilled and knowledgeable musician. He lived during the reign of Abdullah Khan (1583-1598) and was distinguished by his talent among the musicians and artists of that time. One day, Abdullah Khan organizes a competition in the madrasa he built in Bukhara. Another musician participating in the competition will perform a song he composed in the presence of Ali Dost Khan. Hearing this, Maulana Husayn Akhund asked him: “My friend, did you create this as an act or as a word?” Ali Dost says that he composed it as an act. Maulana Husayn Akhund says: “A deed cannot be done without effort, and you have done it without effort”. In this very place, thanks to the beautiful process between Zaky teacher and student, a new unique work is born. Ali Dost also became a mature composer under the guidance of his teacher Maulana Husayn Akhund [1].

In the treatise, Makhzumzada Khorezmi, the son of the famous Sheikh Syed Hossein Khorezmi, the disciple of Ali Dost, was specifically mentioned. Makhzumzoda Khorezmi was famous among the people as an artist who composed many songs and patterns. The patterns he composed are widespread in Bukhara and are loved by musicians. Hafiz Changi, who heard about her, comes to Samarkand to get to know her. At that time, the ruler of Samarkand, Sultan Husayn Mirza, returned from China in triumph, and the people greeted him with great greetings. Poets sing the victory of the ruler with poems and musicians with beautiful melodies. Then Hafiz Changi also composed a song and gave it to the ruler. Savt is so pleased with the ruler that he buries the composer in gold and gifts. This song, created by Hafiz Changi, will become very popular among people. Hearing about this, Makhzumzada Khorezmi called Hafiz Changi to his presence and asked him to perform that famous, new song. Makhzumzada Khorezmi, who listened to the performance, acknowledges the skill of the composer. When Hafiz Changi told him that he wanted to become a student, he began to study. Following his teacher’s recommendations, Hafiz Changi composed seventeen peshravs based on a single maqam veil in a short period of time. All these peshravs are known not only among the people, but also among singers and musicians. One of these peshravs was always performed in all meetings.

Amir Aliakbar Samarkandi, another scientist and master of music, whom Darvish Ali Changi mentioned with high praise, was a unique creator. He studied in Samarkand and attained the rank of Sheikh ul-Islam. However, he does not hesitate to study music. He is also known as the composer of many patterns and songs [1]. Many talented individuals such as Maulana Darvesh, Mir Hoki, Maulana Pir Muhammed Kulol, Ustad Tulaq Nai, Ustad Abdusattar Qonuni, Ustad Arab Qabuzi and Makhdumzada Kotib and

many other talented composers are taught the science of music from Sheikh ul-Islam Amir Aliakbar Samarkandi.

If we look at the ancient treatises, they contain information about the fact that the composers were mostly music connoisseurs, skilled musicians or singers, and were respected among the people and surprised a lot of people with their talents. One such artist was Maulana Qasim Qonuni who lived in Khirat in the 16<sup>th</sup> century and was in the service of Sultan Ibrahim, grandson of Tahmasp. The Sultan appreciated and encouraged his creativity. Maulana Qasim created a number of peshravs, patterns and designs. Among them, the peshrav named “Nozi ghamza” is performed in the 1/2 doira method on the melodies of Hosseini maqom method. Darvish Ali Changi emphasizes in his musical treatise that the melodies of this peshrav are extremely beautiful and gentle. Another famous peshrav composed by Maulana Qasim is performed in the Hijaz melody, in the faktha method, and it is called “Headache Cure”.

Darvesh Ali Changi also mentioned the name of Ustoz Shodi in the “Musical treatise”. He was one of the most respected scholars of his time. Musicologists took into account his instructions and listened to his recommendations. Ustoz Shodi had 12 talented students, each of whom had no equal, and during the time he lived in Khivot, he composed twelve naqshes on Iraqi melodies, using the kar method. He taught each of his students one by one the naqsh he had created and told him that he would give the naqsh to him if he performed it well. Among his students, Khoja Yusuf Andijani performed the naqsh given to him perfectly, and Ustaz Shodi presented it to his student [6]. Later, this naqsh will be popularly known as “Khoja Yusuf naqshi”. In this way, Ustaz Shodi was awarded to his student Ghulamali Shunqor for his beautiful performance of another turkish style composition called “Mohi Hilal”, “Dili shisha” to Mir Gur, “Naqshi Khanjara” to his student Ali Kard, and another one presents to his student Alijon Gijjaki. In addition, Ustad Shodi created a number of melodies, which were performed not only by musicians, but also by singers who put words to these melodies and performed them with love.

Darvesh Ali Changi, in addition to the above-mentioned composers, also mentioned artists who enriched the world of music with new works and tunes. Among them, Mavlana Mirguru, Ali Shunqor, Ustad Ali, Ustad Karmal, Mavlana Zainulobiddin Rumi, Alijon Gijjaki, Shokh Muhammed Dildoz, Mavlana Shaykh Abdurahman Rumi, etc., recognized the works, creativity and musical knowledge of others [7].

## Conclusions

In conclusion, it can be said that the information presented above shows how highly developed the science of music is in the East, how much the love for art is respected. It is appropriate for us to inform every young person who is learning music today that such scientists contributed to the development of our music in ancient times. Moreover, if our young researchers find and study the works for their activities they created and performed, they will make a great contribution to the science of music.

## References:

- [1] Semenov A.A. “Sredneaziatskiy traktat po muzike Darvisha Ali (XVII veka)”, *Toshkent*, 1946.





- [2] Boltaev B.H. “Darvesh Ali Changiy va zamondoshlarida fazoviy (kosmologik) 12-maqom falak burjlari nazariy tamoyillari”, *Analytical Journal of Education and Development*, vol. 02, issue 11, 2022, pp. 85-89.
- [3] Normurodova M.Z. “So‘nggi o‘rta asrlar bastakorlari ijodi Darvesh Ali Changiyning “Musiqiy risolasi”da bastakorlar siymolari”, *Akademicheskije issledovaniya v sovremennoy nauke*, Tom 1, № 18, 2022.
- [4] Xudoyazarova O.A. “Sevimli cholg`ularimiz ajdodlar nigohida”, *Innovative Developments in Sciences, Education and Humanities*. Hosted New York, USA. April, 2022, pp. 245-247.
- [5] Imamov U.Z. “Musiqiy ta’limda mumtoz musiqiy merosni o‘rganishning pedagogik ahamiyati”, *Ilmiy xabarnoma*, ADU, №1, 2017.
- [6] Dadaev A.Sh. “Traktat Farobi o muzikal’noy nauke: Kitabu-l-musika al-kabir (Bol’shaya kniga o muzike)”, *Problemi sovremennoy nauki i obrazovaniya. Nauchno-metodicheskiy jurnal*. № 2 (171), Moskva, 2022, pp. 95-97.
- [7] Matyakubov Sh.B. “Tradisii “Nastavnik i uchenik” v obuchenii tradisionnogo ispolnitel’sstva. *Problemi pedagogiki. Nauchno-metodicheskiy jurnal*. № 2 (41), 2019, pp. 9-10.
- [8] Umarov A., Bekmurodov M. “Madaniyat va san’at atamalarining izohli lug‘ati”, Toshkent: *G‘afur G‘ulom nomidagi nashriyot-matbaa ijodiy uyi*, 2015.
- [9] “O‘zbek tilining izohli lug‘ati”, 1-5 jildlar, Toshkent: “O‘zME” Davlat ilmiy nashriyoti, 2006-2008.
- [10] “Slovar inostrannix slov”, 12-e izd., stereotip, Moskva: “*Russkiy yazik*”, 1985.

UDC:78.01, 78, 78.07, 780.7

## FROM THE HISTORY OF KHOREZM MAQAMS

**Khudayberganov Samandar Kuzievich**

*Acting Professor, Department of Art,*

*Urgench State University*

[navouzbek@mail.ru](mailto:navouzbek@mail.ru)

**Annotatsiya.** Qariyb ikki asr davomida bir hodisa uchun to‘rt xil belgi qo‘llanilgan: Xorazm musiqali shashmakomi, yetti maqom, Olti yarim maqom, Tanbur maqomlari. Keyinchalik amalda bir nom – Olti yarim maqom tobora mustahkamlanib bordi. Shunisi e‘tiborga loyiqki, bu variantlarda Shashmakga o‘xshatib, maqomni maqom tizimi sifatida ta’riflashning miqdoriy tomoni: olti, olti yarim va yetti ravish shakllari birinchi o‘ringa chiqadi.

**Kalit so‘zlar:** *maqom, tanbur, musiqa, kontekst, nota, amaliyot, nazariya, manba, shakl.*



**Аннотация.** В течение почти двух веков употребляются четыре разных обозначения для одного явления: Музыкальный Шашмакам Хорезма, Сем макамов, Шест с половиной макамов, Тамбурные макамы. В последующем, на практике все больше утверждается одно название Шест с половиной макамов. Примечательно, что в этих вариантах по аналогии с Шашмакам на первый план выходит количественная сторона определения макама как ладовой системы: шест, шест с половиной и сем ладообразований.

**Ключевые слова:** маком, танбур, музыка, контекст, нотация, практика, теория, источник, форма.

**Abstract:** For almost two centuries, four different designations have been used for one phenomenon: Musical Shashmaqam of Khorezm, Seven Maqams, Six and a Half Maqams, Tanbur Maqams. Subsequently, in practice, one name, Six and a Half Maqams, is increasingly asserted. It is noteworthy that in these variants, by analogy with Shashmaq, the quantitative side of the definition of maqam as a modal system comes to the fore: six, six and a half, and seven modal formations.

**Keywords:** maqam, tanbur, music, context, notation, practice, theory, source, form.

## Introduction

In the book “Essays on the Music of Khorezm”, in order to comprehensively cover the phenomenon of maqams in this oasis and to differentiate two genre varieties, other pairs of concepts are used: “Dutar maqams” and “Tanbur maqams” or “Dutar maqams” and “Six and a Half Maqams” [1]. In relation to the latter, depending on the context, other synonyms were also used, such as “Olti yarim maqom (Six and a Half Maqams)” and “Yetti maqom (Seven Maqams)”. And even earlier, in some lists of the Khorezm tanbur notation, the expression “Shashmaqomi musiqiy Xorazm (Musical Shashmaqam of Khorezm)” is found [2].

## Literature Review

The rich musical tradition of Central Asia, particularly the maqam system, has been a subject of fascination for scholars and enthusiasts alike. The maqams of Khorezm, an ancient region that now lies within the borders of Uzbekistan, have played a significant role in shaping the musical heritage of the region. This paper explores the historical evolution and preservation efforts surrounding the Dutar maqams and Six-and-a-Half Maqams in Khorezm [3-5].

Drawing on historical research and ethnographic analysis, this study seeks to shed light on the intricate melodies, rhythms, and improvisation techniques that characterize these unique maqam traditions. It delves into various sources such as musical treatises, notation collections, interviews with musicologists, oral histories from disciples involved in recording and preserving maqams to provide a comprehensive understanding of their significance [6].

The paper aims to contribute to a deeper understanding of Central Asian musical traditions by unveiling the complexities inherent in these maqam systems. By examining these traditions within their historical context while also considering contemporary

preservation efforts, this study presents an interdisciplinary approach that combines scholarly research with first-hand accounts.

### **Research Methodology**

A combination of historical research and ethnographic analysis. The authors have conducted a thorough review of existing literature on the topic, including musical treatises, notation collections, and historical documents related to the maqams of Khorezm. Additionally, the author appears to have incorporated oral history by referencing interviews with musicologists and disciples who were involved in recording and preserving the maqams.

Overall, future research on this topic may benefit from an interdisciplinary approach that combines historical analysis, oral history interviews, ethnographic fieldwork in Khorezm itself if possible (considering local attitudes toward heritage), as well as musical analysis based on available notations and recordings.

### **Analysis and Results**

From a logical point of view, the two-genre definition of Khorezm maqams seems more correct and appropriate. It corresponds to real musical practice and in the general context of maqamate corresponds to the two-genre essence of the Bukhara, Khorezm and Fergana traditions, which is also convenient for making comparative characteristics. Based on these facts, instead of the idiom “Khorezm maqams” in the sense that was not quite rightfully rooted in the second half of the twentieth century, we prefer to return to the old sought-after definitions “Dutar maqams” and “Six and a half maqams”. The first one means the old style of classical music, which has its roots in the era of the Khorezmshahs (11<sup>th</sup>-12<sup>th</sup> centuries), during the heyday of science and art. The second one means a new form of Khorezm maqams, created in the early 19<sup>th</sup> century on the model and likeness of the Bukhara Shashmaqam. Traditionally, the Six and a Half Maqams were originally cultivated in the elite palace environment. In this regard, the old tradition of Dutar Maqams became associated with a more democratic, everyday form, common in urban circles.

A somewhat curious situation has also developed with regard to determining the priority source study base of the Khorezm Six and a Half and Dutar Maqams. The materials available to us on the Bukhara Shashmaqam, starting with the musical treatises-bayaz of the 19<sup>th</sup> century, the musical collection of V. Uspensky, the book of Fitrat – up to the musical notation of Ari Babakhanov, all line up in one logical row. There is a difference between them only in details, but there are no contradictions in the coverage of the phenomenon as a whole. On the contrary, they complement each other well as a common source study base. In principle, this is a single factual basis, recorded in different periods of the history of the development of the same musical collection called “Bukhara Shashmaqam”. In essence, this is a very important process aimed at improving the foundations of notation and expanding the scope of its application. In fact, tanbur notation is a unique document of its kind of a complete record of the Six and a Half Maqams and samples of Dutar Maqams. In essence, this new form of theoretical understanding, a “scientific and practical treatise” on the foundations of classical music of Khorezm. The significance of tanbur notation goes far beyond the regional scale.



The absurdity of the situation is that due to the abrupt change in national policy and attitudes towards cultural heritage in the early 1930s, classical music suffered the most in the field of fine arts, as an element of the “feudal-palace heritage” and the documents, primary sources and living bearers of traditions associated with it. Thus, outstanding masters of maqams found themselves out of work. Consequently, their attributes, including rare manuscripts of tanbur notation, also became unclaimed. Soon, incomparable masters-bearers were replaced by inexperienced musicians, oriented towards other methods of fixing large musical collections in memory by means of their notational fixation. Accordingly, the methods of scientific understanding of maqams also changed. In 1934, an expedition was organized to Khiva, consisting of musicologists E.E. Romanovskaya and I.A. Akbarov, to record maqams. The background to this action is as follows: V. A. Uspensky at one time long sought from the Government of Uzbekistan the allocation of funds for a trip to Khorezm. In a letter to V. Belyaev, he calls Khorezm “Musical Mecca” and expects an answer to key questions related to the origins of Uzbek classical music from the scientific and ethnographic expedition to this region.

Even during the Turkmen expedition of 1927-1928, being very close to Khorezm, V.A. Uspensky vividly asked the oldest musicians about the musical traditions of this ancient center of culture. But by 1934, by order of the Government of Uzbekistan, he was engrossed in work on the opera “Farhad and Shirin” and was forced to send his students E. Romanovskaya and I. Akbarov to the “Khorezm expedition”. E. Romanovskaya and I. Akbarov recorded Tanbur maqams from Matyakub Kharratov on a gramophone with wax cylinders. The quality of storage of sound tracks in them was rather poor. And decoding required multiple scrolling of these records. Consequently, the cylinders quickly failed. According to the oral recollections of I. Akbarov, the cylinders soon became completely unusable and were disposed of. It was initially known that the censorship would not allow the verbal texts of the vocal parts of the Sufi persuasion. Therefore, as with V. Uspensky in his work on the Bukhara Shashmaqam, the course was taken on the “tanbur” version, that is, the recording of maqams without poetic texts. According to I. A. Akbarov, he recorded the poetic texts separately.

At the same time, not having the appropriate education (I. Akbarov did not study in a madrasah, and his knowledge of Arabic writing was at the elementary school level), the young musicologist experienced great difficulties in understanding the content of the poetic texts of maqams. And he had a hard time understanding poems in Tajik. Thus, the musical materials published by E. Romanovskaya in 1939 under the title “Khorezm Classical Music” cannot be considered fully reliable texts of the Six and a Half Maqams of Khorezm. The repressions of 1937 affected the great masters, the last of the Mohicans Matyakub Kharrat (1864-1939) and Muhammad Kamil Devani (1887-1938). The tragic death of these two enlightened giants of classical music of Khorezm seems to close the “golden page” of the maqam art of this tradition. Fortunately, they have preserved unique manuscripts of tanbur notation, which contain musical and verbal texts of the Six and a Half Maqams and Dutar Maqams of Khorezm.

In 1958, the sixth volume was published in the “Uzbek Khalk Musiqasi” series, which, although a priori called “Khorezm maqams”, actually covers an incomplete version of only the Six and a Half Maqams and without the Dutar Maqams at all [7].

Unlike the recordings of E. Romanovskaya, which never entered into wide circulation, the collection of Matniyaz Yusupov, dedicated to the Khorezm Maqams, was presented as a musical text that had passed the appropriate censorship. Consequently, this material was perceived as an official document in state educational institutions and scientific institutions. They were the basis for educational programs and scientific research. To fully understand the paradoxical situation with the recording of Khorezm maqams in the European notation system, it should be noted that only the masters themselves did not react to the publication and expressed their “silent disagreement”.

It was a whole generation of musicians, from popular singers and instrumentalists to renowned experts in the maqam traditions of Khorezm, who were respected far beyond Khorezm: Khadzhikhan Boltayev, Kamiljan Ataniyazov, Allanazar Khasanov, Ruzmat Dzhumaniyazov and others. Of course, they did not publicly express their disagreement with the content of the music collections.

### Conclusions

In conclusion, the phenomenon of maqams in Khorezm is complex and multi-faceted. The differentiation between Dutar maqams and Six and a Half Maqams is more appropriate than a blanket term like “Khorezm maqams”. The study of these maqams has been hindered by political changes and repressions, leading to an incomplete understanding of the tradition. However, efforts to record and preserve these musical traditions have been ongoing, ensuring that the rich heritage of Khorezm classical music continues to be studied and appreciated.

### References:

- [1] Mullo Bekjon Raxmon ugli, Muxammad Yusuf Devon-zoda “Xorazm musiqiy tarixchasi,” *Moskva*, 1924.
- [2] Matyakubov O. “Istoki I prinsipi xorezmskoy tanburnoy notatsii,” *Toshkent*, 2018.
- [3] Levin T. “From Bards to Commissars: Music-based performance strategies among Soviet Makom musicians,” *In Music and Politics*, Vol. 12(2), 2018.
- [4] Ziyoev X. “Ma’naviy Metodologiya – O’zbek Maqom musiqisi nazariyasi va metodologiyasi (Spiritual Methodology - Theory and methodology of Uzbek Makom music),” 2005.
- [5] Adashbekova D. “Traditional Music Instruments of Uzbekistan – Dotar And Its Role in Folklore Culture,” *In International Conference on Traditional Art and Modern Development of Turkic World Countries*, 2010.
- [6] Aminov T. “The Musical Culture of Turkic-Mongol Peoples as An Original Source for The Development of World’s Musical Art,” *International Scientific-Theoretical Conference, “Turkiston Ijodidan Mustakillikka”*, 2017.
- [7] “Uzbek xalq musiqasi,” VI tom. Khorezm makoms. In the musical notation by Matniyaz Yusupov. *Toshkent*, 1958.

## MODERN PROBLEMS OF TOURISM AND ECONOMICS

UDC: 336.7, 334, 339, 339.3

### GENERAL AND SPECIAL CHARACTERISTICS OF ECONOMIC DISCOURSE

**Mohigul Asronova Musaboyevna**

*Associate Professor, Andijan State University*

[mohigul.asronova@mail.ru](mailto:mohigul.asronova@mail.ru)

**Annotatsiya.** Ushbu maqola “Iqtisodiy diskursning umumiy va xususiy xususiyatlari” mavzusida iqtisodiy diskursni tahlil qilish va uning turli jihatlarini o‘rganishga bag‘ishlangan. Maqolada iqtisodiy diskursning asosiy komponentlari, jumladan, terminologiya, uslub, kommunikativ strategiyalar va ularning auditoriya bilan muloqotdagi o‘rni ko‘rib chiqiladi. Umumiy xususiyatlar sifatida iqtisodiy diskursning xalqaro va milliy iqtisodiy muammolarni yoritishdagi roli, shuningdek, iqtisodiy nazariyalar va amaliyotlar o‘rtasidagi bog‘liqlik tahlil qilinadi. Xususiy xususiyatlar esa muayyan mamlakatlar yoki iqtisodiy tizimlarga xos bo‘lgan elementlarni, madaniy va siyosiy kontekstlardan kelib chiqadigan farqlarni o‘z ichiga oladi.

**Kalit so‘zlar:** *iqtisodiy diskurs, penya, iste‘mol, tovar, miqdor, bank, to‘lov, mulk.*

**Аннотация.** Данная статья посвящена анализу экономического дискурса и изучению его различных аспектов по теме «Общие и особенности экономического дискурса». В статье рассматриваются основные компоненты экономического дискурса, включая терминологию, стиль, коммуникативные стратегии и их роль в общении с аудиторией. В качестве общих черты анализируется роль экономического дискурса в освещении международных и национальных экономических проблем, а также взаимосвязь экономических теорий и практик. Конкретные характеристики включают элементы, характерные для конкретных стран или экономических систем, а также различия, возникающие из культурного и политического контекста.

**Ключевые слова:** *экономический дискурс, деньги, потребление, товар, сумма, банк, платеж, собственность.*

**Abstract.** This article is devoted to the analysis of economic discourse and the study of its various aspects on the topic "General and specific features of economic discourse". The article examines the main components of economic discourse, including terminology, style, communicative strategies and their role in communication with the audience. As general features, the role of economic discourse in the illumination of international and national economic problems, as well as the relationship between economic theories and practices are analyzed. Specific characteristics include elements specific to particular countries or economic systems, and differences arising from cultural and political contexts.



**Keywords:** *economic discourse, money, consumption, commodity, amount, bank, payment, property.*

## **Introduction**

Economic discourse is one of the important aspects of modern society and is aimed at studying economic activity, its main principles and processes. Discussions, ideas and theories in the field of economics, as well as connections between practices form the basis of economic discourse. This article analyzes general and specific features of economic discourse. Common features include factors that determine the uniqueness of economic discourse, in particular, its language and style, context and content. Personal characteristics are formed depending on different economic systems, cultures and political environments. The article examines the specific aspects of economic discourse and their role in society, and also discusses the evolution of economic thought and contemporary trends. Such an analysis helps to deepen the understanding of the economic discourse and reveals its practical significance.

## **Literature Review**

In world linguistics, at the end of the 20<sup>th</sup> century, scientific research on economic-journalistic texts (Ye.O. Shibanova), economic discourse (K.V. Tomashevskaya), separate genres of economic discourse (Ye.G. Bayankina), meanings of economic text (N.K. Kravchenko), the nature of the text as a socio-cultural phenomenon (I.V. Murudyan) became the object of research. In world linguistics, economic discourse has been studied in different aspects in different system languages. In particular, R.N. Kadimova established that the official-departmental economic discourse is a form of the social sphere, researched the linguo-pragmatic features of the economic discourse of the French language [1,49]. V. Krisov development of economic discourse; Methodological and functional and sociolinguistic aspects of economic texts of the Russian language by M. Likun; Ye.A. Logunova features of interactivity on internet sites of economic forums based on materials in English [4, 288]; Ye. Yu. Makhnitskaya, the role of modern economic discourse in the conative paradigm; A.A. Muradyan comparative analysis of discursive dominants in the political and economic spheres of the USA, Russia and France [6, 232]; A.A. Sheremeteva metaphors of economic discourse of the German language; H. Skorezynska, A. Deignan analyzed the audience and purpose of users when choosing economic metaphors, studied them in a monographic plan.

T.A. Yevtushina, N.A. Kovalskaya show that the purpose of the article is to justify the fact that economic discourse is a form of institutional discourse [7, 177]. To do this, they achieved the goal based on the tasks of describing the concept of "economic discourse", distinguishing the different aspects of economic discourse from other types of institutional discourse, and showing the syntactic potential of the economic discourse of a certain period in the selected language.

## **Research Methodology**

The purpose of this study is to identify and analyze general and specific features of economic discourse. The following methodological approaches and methods are used in the research process:

1. Literature analysis: Identify general and specific features by studying the available scientific literature, articles, books and other sources about the economic discourse. This process includes economic theories, macro- and microeconomics, as well as modern economic trends.

2. Thematic analysis: Identify and interrelate key themes in economic discourse (eg, economic growth, inflation, employment, social justice). With the help of thematic analysis, the formation and development of the economic discourse is considered in what contexts.

3. Quantitative and qualitative research: Quantitative analysis is conducted using statistical data and questionnaires to study the characteristics of economic discourse. Qualitative data will also be collected through interviews and focus groups.

These methods allow for the study of different layers of economic discourse, including economists, politicians, and public opinion.

### Analysis and Results

Through this methodology, research helps to provide a deeper understanding of the complex and multifaceted nature of economic discourse, as well as its importance in society. The results of the research serve to determine the evolution of economic ideas and important trends in the modern economy. We can see the economic discourse in the following article:

We have analyzed the units that provide the individuality of the official economic discourse in the text titled "Sales Agreement" and classified them according to their structure in Table 1:

Obligation of the seller to deliver the goods free from the rights of third parties.

The seller must deliver the goods to the buyer free from any rights of third parties, except when the buyer agrees to accept the goods that have the rights of third parties. Failure to comply with this rule gives the buyer the right to demand a reduction of the purchase price or cancellation of the sales contract and compensation for damages, except in cases where it is proven that the buyer knows or should have known that third parties have rights to the goods.

The provisions provided for in this article shall be applied accordingly even in cases where the seller is aware of the existence of claims of third parties during the delivery of the goods to the buyer, if these claims are later recognized as legal in the prescribed manner. excerpt from the decision).

**Table 1.** Comparisons of the terms formed from general lexicon by means of specialization with pure economic terms.

<b>Terms formed from general lexicon by means of specialization</b>	<b>Pure economic terms</b>
1) assessment	1) quantity
2) variety	2) property
3) inconsistency	3) fine
4) quality	4) assortment
5) parties	5) complaint
6) payment	6) standard
7) validity period	7) goods
8) bank day	8) amount

9) cases of liability	9) application
10) daily period	10) contract
11) transportation process	11) notification
12) exchange of goods	12) maximum
13) brand name	13) quantity
14) payment of fees	14) amount of penalty
15) contract number	15) amount of money
16) legal form	16) purchasing enterprise

As can be seen from the analysis in the table, the terms in the text titled "Sales contract" are divided into pure terms and a group of terms whose meaning is specialized from the common lexicon.

The syntax of the official economic discourse of the Uzbek language is also unique. In journalistic economic discourse, syntactic constructions and morphological forms with the content of reporting more about the economic situation and predicting the economic situation gain priority, while in official economic discourse, syntactic devices and morphological forms related to the official-departmental style prevail. In this case, the command-request form is often found in the text of the order, which is considered the genre of official-departmental style. For example: make changes and additions; be filled with a paragraph; be considered a paragraph; be filled with the words; be stated in the editorial; be replaced by words like

Also, in the text of the command, there is a construction of an unknown part of the sentence, which shows that the discourse is aimed at the public. For example: should be presented; such as should be compatible.

In the text of the contract, devices with a negative ratio occupy the main place. For example: filled with goods; is filled when crossed; stored for three years; written using a writing device; filled in as follows; their number is shown; it is indicated which country they are going to; information is displayed, etc.

## Conclusions

The analysis of the lexical composition of the texts related to the official economic discourse presented in the appendices shows that the lexical units that ensure the individuality of the economic discourse in these texts have the following general characteristics:

- firstly, terms related to economic discourse have a simple (one-word), simple compound and complex compound structure;
- secondly, according to the formation and origin of the terms related to the official economic discourse, they are divided into the group of pure terms and the group of terms formed by specialization from the universal lexicon;
- thirdly, according to the semantic structure of the terms related to the official economic discourse, they refer to a thing-subject, a person, a place, a process and a sign.

It is appropriate to distinguish the following as specific features of the syntactic construction and morphological forms of the official journalistic style:

- firstly, in the text of the order, the form of command-request is often found;
- secondly, in the text of the command, the owner is in the construction of the unknown part of the sentence;



- thirdly, in the text of the contract, the devices of unknown proportions occupy the main place.

### References:

- [1] Kadimova R.N. "Delovoy ekonomicheskiy diskurs kak osobiy vid sotsialnoy deyatelnosti (na materiale fransuzskogo yazika)," *Vestnik MGLU*. Vip. 12(723), 2015, pp. 49-59.
- [2] Kadimova R. N. "Lingvopragmaticheskaya xarakteristika delovogo intervyyu kak janra frankoyazichnogo ekonomicheskogo diskursa," dis. ... kand. filol. nauk. M., 2018, p. 231.
- [3] Krisov V. "Razvitie ekonomicheskix diskursov: kakuyu realnost izuchaet ekonomika," 2010, p. 58. URL: <http://discourseanalysis.org/ada11/st77.shtml>
- [4] Likun M. "Russkiy ekonomicheskiy tekst v funktsionalno-stilisticheskom i sotsiolingvisticheskom aspektax," dis. ... kand. filol. nauk. *Odessa*, 2008, p. 288.
- [5] Logunova Ye.A. "Realizatsiya interaktivnosti na internet-saytax ekonomicheskix forumov: na materiale angliyskogo yazika," dis. ... kand. filol. nauk. *Kaliningrad*, 2011, p. 192.
- [6] Maxniskaya Ye.Yu. "Sovremenniy ekonomicheskiy diskurs v kognitivnoy paradigme," *Rostov n/D*, 2007, p. 232.
- [7] Muradyan A.A. "Sopostavitelnyy analiz diskursivnix dominant politicheskoy i ekonomicheskoy sfer SShA, Rossii i Fransii," dis. ... kand. filol. nauk. M., 2018, p. 177.

UDC: 330, 334, 339

## CHINA AND UZBEKISTAN: A NEW ERA OF ECONOMIC COOPERATION AND INVESTMENT

**Olimov Olimboy Djalaladdin Ugli**

*Student at the faculty of Economics,*

*Urgench State University*

[alimovolimboy7@gmail.com](mailto:alimovolimboy7@gmail.com)

**Annotatsiya.** Ushbu maqola Xitoy va O'zbekistonning Buyuk ipak yo'li davrida boshlanib hozirda davom etayotgan va rivojlanib borayotgan iqtisodiy munosabatlarini tahlil qiladi. Xitoy O'zbekistonning asosiy savdo hamkori va sarmoyadoriga aylanganidan beri, tabiiy resurslar, ayniqsa mineral yoqilg'ilar, oltin va paxtaga bo'lgan talabi ortib borayotgani strategik hamkorlikni yanada rivojlanayotganini ko'rsatadi va bu esa ikki mamlakat iqtisodiyoti yuksalishiga sabab bo'lmoqda. Maqolada O'zbekistonning tabiiy gaz yetkazib berishda qahraton qish davrlarida duch keladigan muammolari ham ko'rib chiqiladi va tabiiy gazni Xitoyga eksport qilish va qo'shni mamlakatlardan import qilish o'rtasidagi muvozanatni tahlil qiladi. O'zbekistondagi Xitoyning to'g'ridan-to'g'ri xorijiy investitsiyalarining sezilarli hajmini ko'rsatadigan asosiy statistik

ma'lumotlar, energetika, telekommunikatsiyalar va texnologiyalar kabi sohalardagi muhim rolini aks ettiradi. O'zbekiston Xitoyning avtomobillar va mobil telefonlar kabi texnologik mahsulotlarini tobora ko'proq import qila borishi, ikki mamlakat o'rtasidagi o'zaro iqtisodiy munosabatlar chuqurlashishi, kelajakda bu davlatlarning jahon iqtisodiyotidagi birlashuvini anglatadi. Bu hamkorlik O'zbekistonning modernizatsiya va iqtisodiy balans yo'lidagi muhim qadamini anglatadi va mintaqada yanada yaqin hamkorlik va strategik munosabatlarga yo'l ochadi.

**Kalit so'zlar:** *Tabiiy resurslar, Paxta eksporti, To'g'ridan-to'g'ri xorijiy investitsiyalar, Mineral yoqilg'ilar, Texnologiyalar importi, Investitsion hamkorlik.*

**Аннотация.** Эта статья изучает развивающиеся экономические отношения между Китаем и Узбекистаном, отслеживая его исторические корни от Великого Шелкового пути до современной торговой динамики. Поскольку Китай становится основным торговым партнером и инвестором Узбекистана, исследование подчеркивает взаимную выгоду от обмена природными ресурсами, особенно минеральными топливами, золотом и хлопком. Растущий спрос Китая на высококачественные хлопок и энергетические ресурсы Узбекистана подчеркивает стратегическое партнерство, которое поддерживает экономику обеих стран. В статье также рассматриваются проблемы, с которыми сталкивается Узбекистан в плане поставок природного газа, особенно в период суровых зим, подчеркивая баланс между экспортом в Китай и импортом из соседних стран. Ключевые статистические данные иллюстрируют значительный объем прямых иностранных инвестиций Китая в Узбекистане, что отражает его ключевую роль в таких секторах, как энергетика, телекоммуникации и технологии. По мере того, как Узбекистан все больше импортирует китайские технологические товары, включая автомобили и мобильные телефоны, взаимозависимость между двумя странами углубляется, способствуя экономической устойчивости и позиционированию их для будущего роста в условиях все более взаимосвязанной глобальной экономики. В конечном счете, это партнерство означает значительный шаг в усилиях Узбекистана по модернизации и экономической устойчивости, прокладывая путь к более тесному сотрудничеству и стратегическому согласованию в регионе.

**Ключевые слова:** *Природные ресурсы, Экспорт хлопка, Прямые иностранные инвестиции, Минеральные топлива, Импорт технологий, Инвестиционное сотрудничество.*

**Abstract.** This article examines the evolving economic relationship between China and Uzbekistan, tracing its historical roots from the Great Silk Road to contemporary trade dynamics. With China emerging as Uzbekistan's primary trade partner and investor, the study highlights the mutual benefits derived from the exchange of natural resources, particularly mineral fuels, gold, and cotton. China's growing demand for Uzbekistan's high-quality cotton and energy resources underscores a strategic partnership that bolsters the economies of both nations. The



article also explores the challenges Uzbekistan faces regarding natural gas supplies, particularly during harsh winters, emphasizing the balance between exports to China and imports from neighboring countries. Key statistics illustrate China's substantial Foreign Direct Investment (FDI) in Uzbekistan, reflecting its pivotal role in sectors such as energy, telecommunications, and technology. As Uzbekistan increasingly imports Chinese technological goods, including automobiles and mobile phones, the interdependence between the two nations deepens, fostering economic resilience and positioning them for future growth in an increasingly interconnected global economy. Ultimately, this partnership signifies a significant step in Uzbekistan's modernization efforts and economic sustainability, paving the way for enhanced cooperation and strategic alignment in the region.

**Keywords:** *Natural resources, Cotton exports, FDI, Mineral fuels, Technological imports, Investment cooperation.*

## Introduction

Economic relations between the People's Republic of China and Uzbekistan have a long history, tracing back to the times of the Great Silk Road. Since 1992, Uzbekistan has established itself as a major importing partner for China, particularly in the natural resources sector. China has increasingly relied on Uzbekistan for its abundant supplies of gold and rare earth minerals, essential for the country's industrial and economic development [1-6]. This trade relationship is significant for both nations; China depends on Uzbekistan's natural resources to fulfill its domestic demand, while Uzbekistan benefits economically by exporting these resources to the lucrative Chinese market [7-8]. Furthermore, sectors such as oil and gas also play a critical role in this partnership, highlighted by various reports and analyses [9-11]. The economic landscape is further enriched by recent trade agreements and collaborations, which reflect the evolving dynamics of this bilateral relationship [10-12]. The ongoing partnership in the natural resources sector is mutually beneficial and supports the economic growth of both countries. However, a critical question arises: are China's major import expenditures directed primarily toward Uzbekistan's natural resources?

## Literature Review

The economic relationship between China and Uzbekistan has evolved significantly, echoing the legacy of the ancient Silk Road. Scholars have highlighted how China's growing demand for Uzbekistan's natural resources, such as mineral fuels and cotton, aligns with the country's export strengths. The World Bank (2022) and Asian Development Bank (2023) emphasize the mutual benefits of this cooperation, particularly in energy and agriculture [4-5].

Uzbekistan's Ministry of Investments and Foreign Trade (2022) points out the crucial role of natural gas exports, while also warning of the country's dependency on imports during winter [7]. Sector Research Publications (2023) note that the financial gains from gas exports to China come with challenges that require careful management to ensure energy security [9].

Trade statistics underscore this partnership; the United Nations COMTRADE Database (2022) reports a remarkable increase in trade, with China becoming Uzbekistan's

primary trading partner [1]. This growing connection, with significant Foreign Direct Investment (FDI) in telecommunications and energy, reflects China's commitment to fostering economic ties (Uzbekistan's Statistics Agency, 2023) [3].

The International Monetary Fund (2023) highlights how these deepening bonds contribute to regional stability in Central Asia [6]. Local news outlets (2023) discuss initiatives aimed at diversifying Uzbekistan's economy, while increasing Chinese technology imports, particularly in the automotive and electronics sectors, support modernization efforts [10].

Overall, this literature illustrates a dynamic economic partnership, characterized by opportunities and challenges, as both Uzbekistan and China aim to leverage their collaboration for mutual growth in the evolving global landscape.

## **Research Methodology**

This study takes a comprehensive approach to explore the blossoming economic relationship between China and Uzbekistan, blending both numbers and narratives to paint a fuller picture. By using a mix of data types and thorough analysis techniques, our goal is to better understand how these two nations are navigating their trade interactions and what it means for Uzbekistan's future growth.

### **1. Data Collection:**

- **Quantitative Data:** We started by gathering hard data from respected sources like the United Nations COMTRADE Database, Uzbekistan's Statistics Agency, and reports from the World Bank and Asian Development Bank. This data helped us identify key metrics such as trade volumes and Foreign Direct Investment (FDI) statistics, allowing us to see the big picture of how trade between China and Uzbekistan is evolving.

- **Qualitative Data:** We also combed through important documents like government reports and publications from the Embassy of the Republic of Uzbekistan in Malaysia. These resources gave us valuable insights into the policies and agreements driving this partnership, helping us understand the motivations behind the numbers.

### **2. Statistical Analysis:**

- To make sense of the quantitative data, we employed various statistical techniques to analyze trade figures and FDI trends. We compared year-on-year statistics to illustrate how trade and investment flows have grown, especially in the years leading up to 2023. This analysis highlighted not just the data but the story behind the growth of bilateral ties.

### **3. Case Studies:**

- We conducted in-depth case studies on specific sectors such as energy, telecommunications, and technology. By focusing on these areas, we explored how Chinese investment is making a tangible impact on Uzbekistan's economy, looking at the presence of major Chinese companies and their role in local markets.

### **4. Comparative Analysis:**

- To provide context, we compared Uzbekistan's trade relationships with other countries, particularly focusing on key exports like cotton and energy. This helped us understand how Uzbekistan fits within global trade dynamics and its growing reliance on China as a trading partner.

### **5. Expert Opinions and Interviews:**

- While our primary focus was on secondary data, we reached out for insights from local news outlets and economic experts. Their perspectives offered a nuanced view of the economic partnership and highlighted contemporary opinions about its implications for Uzbekistan's development.

#### 6. Synthesis of Findings:

- Finally, we brought together our quantitative and qualitative findings to draw comprehensive conclusions about the economic partnership. Our goal was to show how trade, investment, and technology transfer are not just abstract numbers but are interconnected elements propelling Uzbekistan toward a more sustainable and modern economic future.

### Analysis and Results

***Balancing gas imports and cotton exports in Uzbekistan-China trade.*** However, even if Uzbekistan gains profit from selling their gas mainly to China, there is always necessity for importing natural gas from the neighbor countries such as Turkmenistan and Russia [11]. The main reason for that demand is because of the frosty winter in Uzbekistan. In this season, the high prices of liquefied petroleum gas impact financially for the population because government need to decrease the supplies of liquefied petroleum gas for gas stations. Therefore, gas stations raise the price for their service. From economic perspective, if Uzbekistan does not export their natural gas to China or other countries, it might be challenging to meet their expenses. When it comes to Uzbekistan's cotton exports to China are driven by the high quality of Uzbek cotton, as well as the competitive prices offered by Uzbek suppliers. China's growing demand for cotton in its textile industry has also contributed to the increasing export volume from Uzbekistan. There are several reasons why China mainly imports cotton from Uzbekistan:

**Quality:** Uzbekistan is known for producing high-quality cotton with long staple fibers, which are in high demand in the textile industry. Chinese textile manufacturers rely on the superior quality of Uzbek cotton to produce high-end textiles and garments.

**Quantity:** Uzbekistan is one of the world's largest cotton producers, with abundant resources and a large amount of cotton available for export. China's significant cotton consumption requires a steady and substantial supply, making Uzbekistan a reliable source for meeting their needs.

**Competitive pricing:** Uzbek cotton is competitively priced in the global market, making it an attractive option for Chinese importers. The cost-effectiveness of Uzbek cotton allows Chinese textile manufacturers to maintain competitive pricing in their own products.

**Trade relations:** China and Uzbekistan have a strong trade relationship, which has facilitated the export of cotton from Uzbekistan to China. Both countries have worked to streamline trade processes and improve logistics to facilitate the efficient flow of goods between them.

The combination of quality, quantity, competitive pricing, trade relations, and diversification factors contribute to China's decision to import cotton from Uzbekistan. This trade relationship benefits both countries by meeting the needs of China's textile industry while generating revenue for Uzbekistan's cotton sector.

**Results and statistics of the economic partnership.** If we look at the statistics, in 2022 according to the United Nations COMTRADE database on international trade, China became the second prime importer of Uzbekistan after Russia with an amount of \$11260.1 million, and China mainly imported mineral fuels, oils, and distillation products with an amount of \$1.07 billion. When it comes to cotton, China spent \$261.51 million to purchase cotton products from Uzbekistan. Compared to 2011, rate of imports increased by \$1.473 billion in 2022. It is clear-cut that China has been importing more natural resources year by year. According to the following statistics, in 2020, China imported 1.62 billion dollars from Uzbekistan, which is 0.32 billion dollars less than the import figure in 2013. The main reason for this is Covid-19. During this period China was the epicenter of this disease, and because of this, China experienced a severe economic downturn, which of course negatively affect the level of imports. Up to now, the good relations between these countries benefit both countries from the economic and financial side, because China is Uzbekistan's main technology equipment supplier. In 2023, Uzbekistan's trade turnover with China increased by 51.5% and amounted to 7 billion, while export amounted to 5 billion, and import increased by 75.2% to 3 billion according to Embassy of the Republic of Uzbekistan in Malaysia. It can be seen that Uzbekistan's export of natural resources to China is beneficial to both sides, and the fact that both countries can buy the goods they need from each other is considered one of the main factors of economic partnership [1].

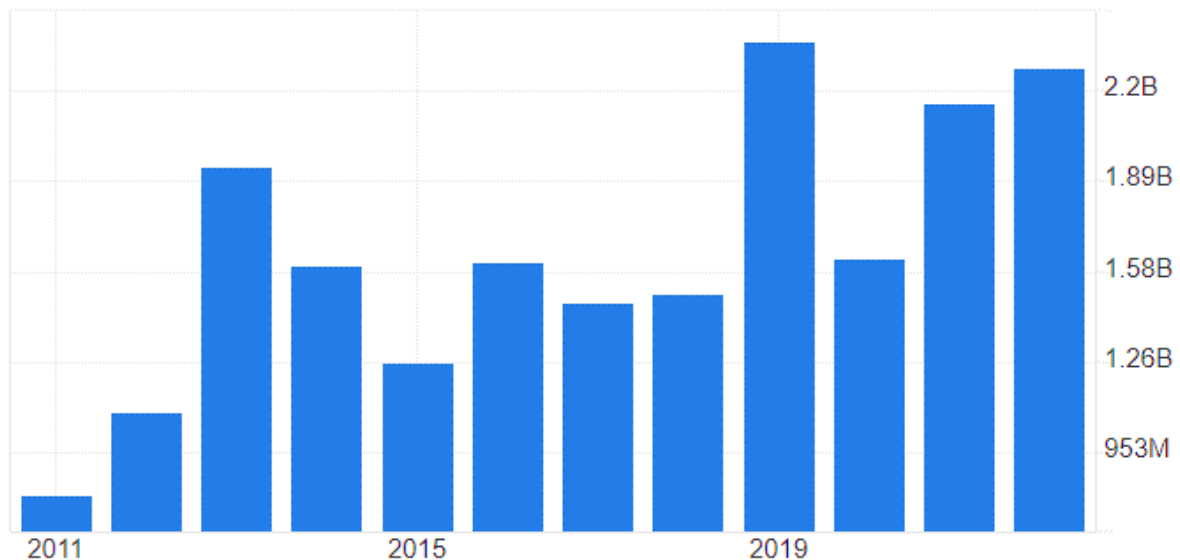

Import expenses of China from Uzbekistan [12].

**China's dominance in fdi: fueling Uzbekistan's economic growth.** When it comes to FDI (Foreign direct investment), China is the major investor of Uzbekistan and according to Uzbekistan's Statistics Agency, in 2023 investments in the country's fixed capital amounted to \$28.5bn, with the share of foreign investment and loans in fixed capital reaching 53.4%. The largest part of foreign investments and loans came from China (25.6% of the total) as it's emphasized. Following that, Russia was in second place (13.4%), Saudi Arabia was third (7.9%), followed by Turkey (6.4%), the United Arab Emirates (5.8%), and Germany (4.3%). Since 2017, China's investments in the economy of Uzbekistan have increased 5-fold and reached billion. By the end of 2022,



China's investments amounted to economy by 0.67 billion (*FDI – 9 million*), in January-September 2023, the total volume of Chinese investments in Uzbekistan amounted to 0.22 billion (*FDI – newscat= “economy” 01 billion*). The areas of investment cooperation are: energy, including renewable energy, oil and gas, chemical, light, automotive, electrical engineering, construction materials production, telecommunications, healthcare, pharmaceuticals, the agricultural sector and others. At present, there are 2,125 enterprises with Chinese capital in Uzbekistan, which is 2.5 times more than 6 years ago. This represents 15% of the total number of all companies with foreign capital present in Uzbekistan. In just 11 months of last year, 605 new enterprises were created with the participation of Chinese capital. Such large Chinese companies as Huawei, ZTE, Wenzhou Jinsheng Trading, JV Peng Sheng, Sinotruk, Heng Bang Textile Central Asia and many others carry out their activities in the Uzbek market [3].

***Uzbekistan's tech imports: China's dominance in autos and mobile phones.*** When we talk about technology, the country which firstly comes to our mind is China. This country is widely exporting its various technological appliances to the number of countries such as Uzbekistan. Uzbekistan's growing appetite for Chinese autos has been well documented. The imbalance also extends to consumer electronics, including mobile phones. The Uzbek Agency for Statistics reported that the country imported 3.1 million mobile phones from China in 2023, far outpacing imports from other sources. Vietnam ranked as the second biggest mobile phone supplier to Uzbekistan, shipping 276,800 units. Third was India, with 37,200 units shipped. The overall total reflected 13.7 percent growth in mobile phone imports over 2022 numbers. The top technological imports of Uzbekistan are motor vehicles including parts and accessories with amount of \$1.28B and vehicles mostly including the electric cars (\$1.12B) which was mostly imported from China (\$7.26B) [2].

## Conclusions

In conclusion, the economic partnership between China and Uzbekistan has solidified significantly, particularly in light of the increased trade and investment activities observed in recent years. China's status as Uzbekistan's primary supplier of technology and equipment, coupled with its substantial foreign direct investment, has fostered a framework for mutual growth and development. The impressive 51.5% increase in trade turnover in 2023, alongside a remarkable influx of Chinese capital into various sectors such as energy and telecommunications, highlights the depth of this collaboration. Additionally, Uzbekistan's rising import of Chinese technological goods, particularly in the automotive and electronics sectors, reveals a growing dependency that benefits both nations. As both countries continue to strengthen their economic ties and explore new avenues for cooperation, they are well-positioned to enhance their economic resilience and expand their influence within the region and beyond. This evolving relationship signifies a critical step forward for Uzbekistan's ambitions for modernization and sustainable growth, charting a promising path for future bilateral engagements.





### References:

- [1] United Nations, “International Trade Statistics,” *United Nations COMTRADE Database*, 2022.
- [2] “Trade Relations between Uzbekistan and China,” *Embassy of the Republic of Uzbekistan in Malaysia*, 2023.
- [3] “Foreign Direct Investment Report,” *Uzbekistan’s Statistics Agency*, 2023.
- [4] “Economic Analysis of Uzbekistan’s Trade Relations,” *World Bank*, 2022.
- [5] “Investment Opportunities and Economic Development in Uzbekistan,” *Asian Development Bank*, 2023.
- [6] “Regional Economic Outlook: Central Asia,” *International Monetary Fund*, 2023.
- [7] “Annual Report on Foreign Investments,” *Ministry of Investments and Foreign Trade of the Republic of Uzbekistan*, 2022.
- [8] “Bilateral Trade Statistics with Uzbekistan,” *Chinese Ministry of Commerce*, 2023.
- [9] “The Impact of Chinese Investments on Uzbekistan’s Economy,” *Sector Research Publications*, 2023.
- [10] “Recent Trade Agreements and Economic Developments between China and Uzbekistan,” *Local News Outlets*, 2023.
- [11] U.S. Department of Commerce, “Uzbekistan - Oil and Gas,” *Country Commercial Guides*, 2023.
- [12] “Imports from Uzbekistan,” *Trading Economics*, 2023.  
<https://tradingeconomics.com/china/imports/uzbekistan>

**MODERN PROBLEMS OF PEDAGOGY AND PSYCHOLOGY**

UDC: 37, 37.02, 37.09

**DEVELOPMENT OF SOCIOLINGUISTIC COMPETENCE IN  
PEDAGOGICAL PRACTICE****Ibragimova Nazokat Muxtarovna***Doctoral student of Nukus State**Pedagogical Institute*[nazokatibragimova0307@gmail.com](mailto:nazokatibragimova0307@gmail.com)

**Annotatsiya.** Ushbu maqolada sotsiolingvistik kompetentsiya samarali muloqot va pedagogik faoliyatning muhim elementi sifatida ko'rib chiqiladi. Sotsiolingvistik kompetentsiyaning tuzilmasi tahlil qilinadi, bu madaniy an'analar va qoidalarni bilish, shuningdek, muloqot vaziyatiga qarab nutqni moslashtirish qobiliyatini o'z ichiga oladi. Tadqiqot metodologiyasi, verbal kompetentsiya komponentlari va ushbu kompetentsiyalarni rivojlantirishga hissa qo'shadigan ta'lim usullariga alohida e'tibor qaratiladi. Ta'lim jarayonida texnologiyalarning o'rni ko'rib chiqiladi. Maqolada o'qituvchilar uchun madaniyatlararo muloqotning ahamiyati ta'kidlanadi va interaktiv ta'lim usullaridan foydalanish bo'yicha tavsiyalar beriladi.

**Kalit so'zlar:** *Sotsiolingvistik kompetentsiya, kommunikativ kompetentsiya, madaniyatlararo muloqot, verbal kompetentsiya, interaktiv ta'lim usullari, ta'limda texnologiyalar.*

**Аннотация.** В данной статье рассматривается социолингвистическая компетенция как важный элемент эффективной коммуникации и педагогической деятельности. Анализируется структура социолингвистической компетенции, включающая знание культурных традиций и норм, а также умение адаптировать речи в зависимости от коммуникативной ситуации. Особое внимание уделяется исследовательской методологии, компонентам вербальной компетенции, методам обучения, способствующим развитию этих компетенций. Рассматривается роль технологий в образовательном процессе. В статье подчеркивается важность межкультурной коммуникации для педагогов и предлагаются рекомендации по использованию интерактивных методов обучения.

**Ключевые слова:** *Социолингвистическая компетенция, коммуникативная компетенция, межкультурная коммуникация, вербальная компетенция, интерактивные методы обучения, технологии в образовании.*

**Abstract.** This article examines sociolinguistic competence as a vital element of effective communication and pedagogical practice. It analyzes the structure of sociolinguistic competence, which includes knowledge of cultural traditions and norms, as well as the ability to adapt speech according to the communicative situation. Special attention is given to research methodology, components of verbal competence, and teaching methods that contribute to the development of these competencies. The role of technology in the educational process is also considered.

The article emphasizes the importance of intercultural communication for educators and offers recommendations for using interactive teaching methods.

**Keywords:** *Sociolinguistic competence, communicative competence, intercultural communication, verbal competence, cross-cultural skills, interactive teaching methods, technology in education.*

## **Introduction**

Language serves as a vital means of communication and a powerful tool for forming and sustaining social connections. When people meet in social settings, they often form initial impressions of each other's background and social standing based on their speech. These impressions may be accurate or misleading, but as the conversation progresses, a deeper understanding of each participant emerges, shaping the social dynamics. As Valentina Normuratova and Aisulu Kinzhemuratova observe, foreign languages were traditionally studied in schools mainly for completing assignments and passing exams, rather than for meaningful communication [1]. However, students now need to learn languages for active use: to communicate effectively by choosing appropriate words and styles, respond to changes in style and register, and understand jokes and cultural nuances. In the context of globalization and increasing multiculturalism, the ability to accurately interpret and use linguistic resources has become especially important. People from different cultures often have varying speech norms and customs, which can lead to misunderstandings and conflicts. Developing sociolinguistic competence enhances understanding and respect for cultural differences, facilitating more harmonious intercultural interactions. This aspect is particularly important for educators, who must communicate effectively with students from diverse cultural and social backgrounds. Unfortunately, as Omaggio correctly points out, sociolinguistic competence is rarely treated as an independent topic or as an integral aspect of language teaching, as instructors may feel uncertain about teaching the sociocultural aspects of language due to perceived insufficient knowledge in this area [2]. It is essential to recognize that classroom activities occur within the confines of four walls, in an artificially created atmosphere, whereas sociolinguistic competence is better developed through direct contact with native speakers of the language. Therefore, it is challenging for teachers to teach or guide students in this area if they lack this knowledge themselves. To address this situation, it is necessary to create conditions that allow teachers to first acquire knowledge about various social situations, such as through contact with native speakers, study abroad programs, or training by native speakers with a focus on sociolinguistics.

## **Literature review**

In the dictionary of linguistic terms, “sociolinguistics” (from the Latin soci(etas)—society + linguistics) is interpreted as a branch of linguistics that studies the social life of language and the conditions of its social development. This term derives from the synthesis of sociology and linguistics. Sociolinguistic competence refers to the ability to use a second language appropriately in various social contexts, taking into account factors such as age, gender, status of participants, and the formality of the setting “without this ability, even the most perfectly grammatical utterances can convey a meaning entirely different from what the speaker intended” [3]. It is considered a crucial

element of communicative competence, enabling individuals to organize their speech activities in accordance with the sociolinguistic norms of a specific national linguistic and cultural community. This competence encompasses several key aspects. First, it involves knowledge and understanding of cultural traditions and norms associated with language use. For example, certain cultures have specific politeness rules that must be followed when communicating with different social groups. Second, it includes the ability to adapt one's speech according to the communicative situation. This involves selecting the appropriate style and register of speech and using various linguistic strategies to achieve communicative goals.

Sociolinguistic competence also includes the ability to perceive and interpret nonverbal cues and signals. Nonverbal communication plays a significant role in interactions, and its meaning can vary greatly across cultures. For instance, gestures, facial expressions, and body movements may have different meanings and interpretations depending on the cultural context [4]. Understanding such differences helps avoid misunderstandings and facilitates more effective communication.

Research on sociolinguistic competence focuses on two main aspects. First, it explores sociolinguistic competence as a component of communicative competence, encompassing both linguistic and pragmatic skills. Linguistic competence involves knowledge of the language, its structure, and rules of use, while pragmatic competence relates to the ability to apply this knowledge in real communicative situations. Second, it considers sociolinguistic competence as part of sociocultural competence, emphasizing the speech characteristics of people of different ages, genders, and social classes. This includes studying how various social and cultural factors influence language use. For example, researchers examine how gender differences are reflected in speech practices or how social status affects the choice of vocabulary and speech style [5].

## **Research Methodology**

The research methodology for studying the incorporation of sociolinguistic competence in language education can be approached using a mixed methods design that combines qualitative and quantitative research techniques. Here is an outline of a potential research methodology for this study.

## **Analysis and Results**

### ***CEFR in Sociolinguistically Oriented Learning***

One of the primary goals of developing the Common European Framework of Reference for Languages (CEFR) was to encourage language educators to reassess their teaching methods by considering students' needs, setting relevant objectives, and tracking their progress. This framework advocates for an "action-oriented approach," [6] focusing on what learners need to achieve in practical communication situations. CEFR provides clear guidelines for achieving different levels of language competence, including skills in understanding and using language in socially relevant situations. This contributes to a deeper understanding of cultural differences and helps students develop the ability to adapt their speech according to context and audience.

According to CEFR, language instruction should encourage students to act in real-life situations, express their ideas, and complete various tasks. For example, school

students at the A2 level, according to CEFR, should be able to “communicate simply and effectively using basic common expressions and adhering to basic communication rules, engage in short social interactions, use polite forms of greetings and addresses, and respond to invitations, offers, apologies, etc.” [7]. They should also be able to understand the general meaning of what is said in everyday situations, adhere to basic cultural norms, and convey essential information, provided that the speakers articulate clearly in standard language and the student can request repetition and clarification.

Doesn't matter what your level is in English language, but it is important to have sociolinguistic competence to be confident while speaking. Incorporating interactive games and small group work into the educational process at school helps achieve learning goals related to sociolinguistically oriented instruction. Integrating sociolinguistically oriented exercises is crucial for developing students' sociolinguistic competence. Regardless of students' English proficiency levels, there are always opportunities to enhance their socio-pragmatic use of the language. Bardovi and Harlig (1996) argue that language knowledge does not always correspond to the ability to use it correctly in social contexts, which requires the development of sociolinguistic competence [8].

### ***Pedagogical Practice***

An analysis of studies on sociolinguistic and speech competencies shows that these competencies have mainly been studied as those acquired in the process of learning foreign languages. Linguistic competence is defined as the ability to express speech experiences, knowledge of the language basics, and the application of language units and categories. Pedagogical communicative competence among students is formed not only through pedagogical education but also through socialization. Bakum rightly emphasizes this statement: “Such dual development underscores the comprehensive nature of communicative competence among students” [9]. However, many universities struggle to organize student exchange programs or invite foreign specialists to conduct workshops. Therefore, including activities aimed at developing sociolinguistic competence is critical for gradually increasing students' awareness of social and cultural aspects. Nowadays, students often use digital materials that can provide authentic contexts for learning and developing sociolinguistic skills, but improper use of these materials can be harmful. Hence, teachers' important task is to analyze, evaluate, and incorporate digital tools and social media into the educational process, as well as provide students with opportunities for self-directed learning. Teachers should not only impart knowledge but also act as mediators in the process of cultural exchange, helping students develop sociolinguistic skills. This includes teaching an understanding of the cultural and social contexts in which language is used and developing the ability to adapt to different communicative situations. It is essential that future educators can effectively use language to foster constructive and productive educational interactions.

### ***Teaching Methods***

Teaching sociolinguistic competence to students at the A2 level requires diverse teaching strategies. Teachers should create a supportive learning environment that encourages students to experiment with language and its use in various social and cultural contexts. These can include interactive activities, role-playing games, discussions, analysis of cultural texts and situations, and the use of multimedia resources. Such methods help learners better understand and internalize complex



linguistic and cultural concepts, developing their communicative skills in real situations. Khalilova claims that “Interactive teaching methods promote deeper material comprehension and critical thinking development in students” [10]. Interactive methods, such as role-playing and simulations, allow students to practice their skills in a safe and supportive environment. Discussions and group projects encourage the development of critical thinking and teamwork skills. The analysis of cultural texts and situations helps students better understand and appreciate the diversity of cultural practices and norms. Here are some strategies that can be used:

### 1. Role-Playing Games

Role-playing games engage students in simulating real-life situations to practice using language in different contexts. This strategy helps students develop their sociolinguistic competence by allowing them to practice language skills in a safe and supportive environment. For example, students might simulate a job interview, a business meeting, or a conversation with a friend or family member.

Example: The teacher organizes a role-play where students simulate a job interview. One student plays the role of the employer, and another plays the role of the job candidate. They discuss typical interview questions and answers, including greetings, introductions, and descriptions of skills and experience.

### 2. Real-Life Scenarios

Real-life scenarios involve students in problem-solving tasks, helping them develop sociolinguistic competence in various social contexts. This strategy encourages students to think critically and apply their language skills to solve problems, such as resolving conflicts or making decisions.

Example: Students work in pairs to solve a real-life problem, such as deciding how to handle a difficult customer at a store. They use appropriate language and politeness strategies to resolve the situation, adapting their speech to the context.

### 3. Technology

Technology plays a significant role in the development of sociolinguistic competence. With the help of multimedia resources, students can access authentic materials, such as videos, audio recordings, and online forums, which provide exposure to different languages, dialects, and cultures.

Example: The teacher uses a video clip from a foreign language TV show to demonstrate how people from different cultures greet each other. Students then discuss the differences and similarities in greetings and analyze the sociolinguistic norms behind them.

### 4. Games

Games provide a fun and interactive way to practice sociolinguistic skills. By engaging in games that require communication and negotiation, students can develop their sociolinguistic competence while enjoying the learning process.

Example: The teacher uses a game like "Taboo" to help students practice using alternative expressions when they cannot find the right word. Students must describe a concept without using a list of forbidden words, encouraging them to think creatively and adapt their language.

## Conclusions

In summary, the article emphasizes three key aspects of sociolinguistic competence in pedagogical practice: 1. Essential for Effective Communication: Sociolinguistic competence is crucial for effective communication, especially in multicultural settings. Educators must understand and use language appropriately in diverse social and cultural contexts to foster better interactions with students. 2. Development Through Interactive Methods and Technology: The development of sociolinguistic competence can be enhanced through interactive teaching methods, such as role-playing and real-life scenarios, as well as the integration of technology. These approaches create engaging learning environments that help students internalize cultural norms and linguistic strategies. 3. Priority in Education: Given the increasing globalization and multiculturalism, prioritizing sociolinguistic competence in education is essential. Teachers should be equipped to guide students in adapting to different communicative situations, preparing them for real-world interactions.

## References:

- [1] “Sociolinguistic Competence in Teaching Foreign Languages,” *Eurasian Journal of Learning and Academic Teaching*, Vol. 24, September 2023. ISSN: 2795-739
- [2] Omaggio A.C. “Teaching languages in context: Proficiency-oriented instruction,” 3rd ed. Boston, MA: *Heinle & Heinle Publishers*, 2001.
- [3] Mede E. and Dikilitas K. “Teaching and learning sociolinguistic competence: teachers’ critical perceptions,” *Participatory educational research (PER)*, 2(3), 2015, pp. 14-31. Available from <http://dx.doi.org/10.17275/per.15.29.2.3>
- [4] Filimonova I.S., Chigina N.V. “Nonverbal communications in intercultural communication,” *International Scientific Journal “Innovative Science”*, № 11-2, 2016. ISSN 2410-6070.
- [5] Nazarudin Sodah “The Impact of Social Status on Language Shift: A Case Study on Family Domain Language in Lembar,” *International Journal of Multicultural and Multireligious Understanding*, Volume 6, Issue 3 June, 2019 pp. 959-967. <http://dx.doi.org/10.18415/ijmmu.v6i3.891>
- [6] North B. “The CEFR: Development, Theoretical and Practical issues,” 2007. [http://babylonia.ch/fileadmin/user\\_upload/documents/2007-1/Baby2007\\_1North.pdf](http://babylonia.ch/fileadmin/user_upload/documents/2007-1/Baby2007_1North.pdf)
- [7] Council of Europe “Common European framework of reference for languages: learning, teaching, assessment companion volume with new descriptors,” Available from <https://rm.coe.int/cefr-companion> volume-with-new-descriptors-2018/1680787989 [Accessed 11 December 2022].
- [8] Bardovi-Harlig K. “Pragmatics and language teaching: bringing pragmatics and pedagogy together,” In Bouton, L. F. (Ed). *Pragmatics and Language Learning. Monograph Series*, 7, 1996, pp. 21-39.
- [9] Bakum Z.P. “Pedagogical activity and speech culture,” M.: *Flinta*, 2011.
- [10] Khalilova L.N. “Problems of intercultural communication,” Kazan: *Kazan University*, 2017.

**ACTUAL PROBLEMS OF NATURAL SCIENCES**

UDC: 911, 911.2, 628.8

**IMPACT OF CLIMATE CHANGE ON LANDSCAPES OF KHOREZM REGION****Aminov Bekhzod Bakhram Ugli***Doctorate Student, National**University of Uzbekistan*[aminovbexzod@gmail.com](mailto:aminovbexzod@gmail.com)

**Annotatsiya.** Xorazm viloyati qadimdan o‘zining yam-yashil daryo vodiylaridan tortib, qurg‘oqchil cho‘l kengliklarigacha bo‘lgan rang-barang va jonli manzaralari bilan mashhur. Biroq, bu nozik muvozanat so‘nggi o‘n yilliklarda iqlim o‘zgarishining kuchayib borayotgan ta’siri tufayli tobora muhim ahamiyat kasb etmoqda. Ushbu ilmiy maqolada haroratning oshishi, yog‘ingarchilikning keskin o‘zgarishi va iqlim bilan bog‘liq boshqa omillar ta’sirida Xorazmning tabiiy muhitining o‘zgarishi holati o‘rganiladi. Ushbu tadqiqot geografik ma’lumotlarni har tomonlama tahlil qilish, ekologik tadqiqotlar va iqlimni modellashtirish orqali daryo vohalarining qisqarishidan cho‘llashgan hududlarning kengayishigacha bo‘lgan mintaqaning asosiy landshaft tiplarida kuzatilgan asosiy o‘zgarishlarni aniqlaydi. Biologik xilma-xillik, qishloq xo‘jaligi mahsuldorligi va mahalliy aholi turmush tarziga ta’siri o‘rganilib, ushbu mintaqada barqarorlikni oshirish uchun maqsadli moslashish strategiyalari zarurligini ta’kidlaydi.

**Kalit so‘zlar:** *Iqlim, landshaftlar, GIS, Suv, O‘rta Osiyo.*

**Аннотация.** Хорезмская область издавна известна своими красочными и яркими пейзажами: от пышных зеленых речных долин до засушливых пустынных просторов. Однако этот хрупкий баланс становится все более важным в последние десятилетия из-за усиливающихся последствий изменения климата. В данной научной статье рассматривается состояние изменения природной среды Хорезма в связи с повышением температуры, резким изменением количества осадков и другими факторами, связанными с климатом. Благодаря всестороннему анализу географических данных, экологическим исследованиям и моделированию климата, это исследование определяет ключевые изменения, наблюдаемые в основных типах ландшафтов региона: от сокращения речных оазисов до расширения опустошённых территорий. Изучается воздействие на биоразнообразие, продуктивность сельского хозяйства и местные средства к существованию, что подчеркивает необходимость целевых стратегий адаптации для повышения устойчивости в этом регионе.

**Ключевые слова:** *Климат, ландшафты, ГИС, Вода, Центральная Азия.*

**Abstract.** Khorezm region has long been known for its colorful and vibrant landscapes, from lush green river valleys to arid desert expanses. However, this delicate balance has become increasingly important in recent decades due to the increasing effects of climate change. This scientific article examines the state of

change in the natural environment of Khorezm due to the increase in temperature, sudden changes in precipitation and other climate-related factors. Through a comprehensive analysis of geographic data, ecological studies, and climate modeling, this study identifies key changes observed in the region's major landscape types, from the shrinking of riverine oases to the expansion of decertified areas. Impacts on biodiversity, agricultural productivity and local livelihoods are explored, highlighting the need for targeted adaptation strategies to increase sustainability in this region.

**Keywords:** *Climate, landscapes, Hydro Station, Water, Central Asia.*

## Introduction

Khorezm is an oasis in the north-west of Uzbekistan, bordering the Aral Sea and located at the crossroads of Central Asia, characterized by a complex of diverse landscapes. The Amudarya and its tributaries have long been valued for their fertile river valleys containing oases that have flourished for thousands of years [1-5]. Along with these lush, irrigated landscapes, Khorezm also features vast expanses of arid deserts and semi-deserts with a unique collection of flora and fauna adapted to the region's harsh climate.

However, in recent decades, the delicate balance of Khorezm's natural environment has become more and more acute due to the increasing effects of climate change. Rising temperatures, changing precipitation patterns, and other climate-related factors are causing profound changes across key landscape types in the region, affecting biodiversity, agricultural productivity, and local livelihoods [6-10].

This scientific paper presents a comprehensive assessment of the impacts of climate change on Khorezm landscapes, using a range of geographic data, ecological studies, and climate modeling to illuminate key trends and trajectories across the region. The findings shed light on the complex interrelationships between climate, hydrology and vegetation dynamics, highlighting the need for targeted interventions to enhance and ensure the long-term sustainability of Khorezm's diverse natural environments.

## Research Methodology

In order to investigate the impact of climate change on Khorezm landscapes, this study uses a multifaceted methodological approach that combines geospatial analysis, field-based ecological studies and climate modeling [7, 8]:

1. Geospatial Analysis: High-resolution satellite imagery and aerial photography have been used to map and monitor changes in land cover and vegetation dynamics across Khorezm over the past three decades. Remote sensing data were processed and analyzed using advanced GIS software to quantify changes in the spatial extent and characteristics of key landscape types such as irrigated cropland, desert scrub, and riparian forest.

2. Ecological studies: Field-based ecological studies have been conducted to gain a deeper understanding of remote sensing data and the effects of climate change on the ground. Multidisciplinary teams of botanists, zoologists, and soil scientists conducted detailed assessments of biodiversity, habitat condition, and ecosystem functioning in key landscape units of Khorezm.

3. Climate modeling: Regional climate models were used to analyze Khorezm's future climate scenarios. These models were used to project potential future trajectories

of temperature, precipitation, and other climate variables and to assess their impact on the region's landscapes and natural resources.

Incorporating these complementary methodological approaches, this study was able to generate a comprehensive understanding of the ways in which climate change is altering the landscapes of Khorezm from local to regional scales. The findings presented here build on this robust, multifaceted evidence base to inform adaptation strategies and guide sustainable management of the region's natural environment.

## **Analysis and Results**

Analyzing the impact of climate change on Khorezm landscapes reveals a complex and multifaceted picture, where significant changes have been observed in the main landscape types of the region.

**Irrigated croplands and oases:** the region's fertile river valleys, the backbone of Khorezm's agriculture, are experiencing water shortages due to reduced snow cover in the upstream mountain ranges and erratic rainfall. This leads to a reduction in irrigated cropland and the gradual disappearance of once-thriving oases, with serious implications for food security and rural livelihoods.

**Desert and semi-desert landscapes:** in contrast, Khorezm's arid and semi-arid landscapes are expanding, with desert scrub and bare soil encroaching on previously vegetated areas [5, 8]. This desertification process is associated with rising temperatures, reduced precipitation, and increased drought events-trends that are expected to intensify in the coming decades.

**Riparian and Wetland Ecosystems:** the region's riparian corridors and associated wetlands are also experiencing profound changes with the drying up of once-perennial waterways and the degradation of critical aquatic habitats. This leads to the loss of biodiversity, disrupts the provision of essential ecosystem services and threatens the viability of water-dependent livelihoods.

Taken together, these landscape-level changes indicate the profound and far-reaching consequences of climate change for Khorezm's natural environment. The research highlights the need for targeted adaptation strategies to enhance resilience and protect the region's unique and irreplaceable landscapes in the face of accelerating climate change.

## **Conclusions**

The results of this comprehensive assessment show that Khorezm landscapes are undergoing profound and multifaceted changes in response to the increasing impacts of climate change. From the shrinking of river-fed oases to the expansion of desertified areas, the region's diverse natural environments are facing increasing pressures that threaten their long-term viability and the vital ecosystem services they provide.

These changes at the landscape level have far-reaching consequences for biodiversity, agricultural productivity, and local people's livelihoods in Khorezm. The loss of productive agricultural land, the degradation of critical aquatic habitats, and the degradation of desert conditions all pose serious challenges to regional communities that rely on the natural resources and ecosystem services supported by these landscapes.





Addressing these challenges requires a multifaceted approach based on the best available scientific evidence to develop targeted adaptation strategies. Key priorities should include:

- 1) Strengthen water resources management to increase the sustainability of irrigated agriculture and oasis ecosystems.
- 2) Implement sustainable land use practices to combat desertification and restore degraded landscapes.
- 3) Protect and restore critical riparian and wetland habitats to protect biodiversity and ecosystem services.

The research presented in this study contributes important insights to support the conservation and management of Khorezm landscapes in the face of accelerating climate change, and serves as an important basis for guiding these efforts.

### References:

- [1] Qurbaniyazov R. "Geography of Khorezm."
- [2] Gulomov Y. "History of irrigation in Khorezm region."
- [3] Ramazonov O., Yusupbekov O. "Soil science and farming," Textbook, T: *East*, 2003, p. 270.
- [4] Ramazonov O., Yusupbekov O. "Soil science and farming," Textbook, T: *East*, 2005, p. 270.
- [5] Zakirov Sh.S. "Fundamentals of landscape science," Study guide, T.: *University*, 2010, p. 138.
- [6] Zokirov Sh.S., Tashov X.R. "Landscape studies," Study guide, T.: *University*, 2016, p. 252.
- [7] Zakirov Sh.S. "Anthropogenic and applied landscape science," Study guide, T: *University*, 1998, p. 66.
- [8] Abdullaev K.A. "Fundamentals of biogeochemistry and soil protection," Study guide, T: *Teacher*. 1989, p. 127.
- [9] <https://uz.wikipedia.org>
- [10] <https://geografiya.uz>



UDC: 54, 54-3, 54-4, 542.9, 543.3

## BROMINATION REACTIONS OF 2-ARYLQUINOLINE DUBAMINE

**Niyazmetov Azamat Rahmatjonovich**

Associate Professor at Urgench State  
University

[azamat.niyazmetov1990@urdu.uz](mailto:azamat.niyazmetov1990@urdu.uz)

**Annotatsiya.** Maskur ishda 2-arilxinolin alkaloidi dubamini N-bromsuksinimid va molekulyar brom bilan bromlash reaksiya natijalari berilgan. Dubamini N-bromsuksinimid bilan reaksiyasi DMFA olib borib 78.4 % unum bilan bromdubamin olindi. Lekin erituvchi sifatiga muzli sirka kislota ishlatib molekulyar brom bilan reaksiya olib borilganda dubamining bromgidrati olindi. Sintez qilingan moddalarni tuzilishi IQ,  $^1\text{H}$  YaMR,  $^{13}\text{C}$  YaMR, Mass kabi fizik usullar bilan isbotlandi.

**Kalit soʻzlar:** *Xinolin, bromlash reaksiyasi, dubamin, elektrofil almashinish reaksiyasi.*

**Аннотация.** В данной работе представлены результаты реакции бромирования 2-арилхинолинового алкалоида дубамина N-бромсукцинимидом и молекулярным бромом. Дубамин взаимодействовал с N-бромсукцинимидом в ДМФА с получением бромдубамина с выходом 78,4%. Однако при взаимодействии с молекулярным бромом с использованием ледяной уксусной кислоты в качестве растворителя был получен гидробромид дубамина. Структура синтезированных веществ была доказана с помощью таких физических методов, как ИК,  $^1\text{H}$  ЯМР,  $^{13}\text{C}$  ЯМР, Масс.

**Ключевые слова:** *Хинолин, реакция бромирования, реакция электрофильного замещения.*

**Abstract.** The results of the bromination reaction of the 2-arylquinoline alkaloid dubamine with N-bromosuccinimide and molecular bromine are presented in this paper. Dubamine was reacted with N-bromosuccinimide in DMF to obtain bromdubamine with a yield of 78.4%. However, when reacting with molecular bromine using glacial acetic acid as a solvent, hydrobromide of dubamine was obtained. The structure of the synthesized substances was proved by physical methods such as IR,  $^1\text{H}$  NMR,  $^{13}\text{C}$  NMR, and Mass.

**Keywords:** *Quinoline, bromination reaction, dubamine, electrophilic substitution reaction.*

### Introduction

The search and creation of various biologically active substances based on the chemical modification products of substances extracted from natural sources is one of the important directions of scientific research conducted by world scientists. Quinoline alkaloids are found in many members of the Rutaceae family such as *Dictamnus angustifolius*, *Haplophyllum latifolium*, *Haplophyllum dubium*, *Haplophyllum griffithianum*. Quinoline ring heterocyclic compounds have antimicrobial, anticancer,

antimycobacterial, anticonvulsant, and anti-inflammatory properties [1]. At the same time, many scientists have observed in the results of their scientific research that the presence of halogen atoms in quinolines increases their biological activity [2].

Bromination reactions of aromatic compounds such as KBr [3],  $\text{AlBr}_3 + \text{KNO}_3$  [4],  $\text{HBr} + \text{DMSO}$  [5], N-bromosuccinimide [6], molecular bromine ( $\text{Br}_2$ ) [7],  $\text{ZnBr}_2 + \text{Pb}(\text{CH}_3\text{COO})_4$  [8] were carried out in the presence of reagents and thoroughly studied, alternative reaction conditions were found, and approximate reaction mechanisms were suggested. In recent years, N-bromosuccinimide and molecular bromine ( $\text{Br}_2$ ) have been widely used to obtain many alkaloid brominated products [9-13]. In the results of studies conducted by scientists around the world in 1986-2020 on the synthesis of 2-aryl quinolines, 20-99 % of yields were synthesized from dubamine [14-20].

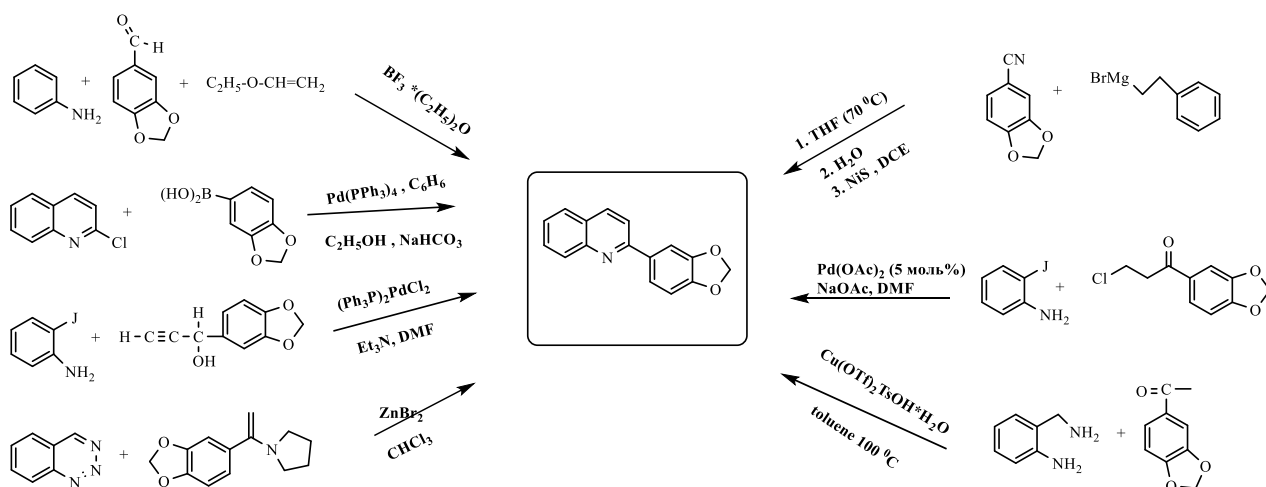

**Figure 1.** Schematic view of the reactions earlier done by abroad researchers [14-20].

However, its derivatives containing different functional groups were not obtained. In our previous works, we nitrated dubamine under 3 different methods and provided information on the biological activity of the products synthesized based on the obtained nitro product [21-23].

## Research Methodology

IR spectra were recorded from KBr pellets on a System Fourier spectrometer. PMR and  $^{13}\text{C}$  NMR spectra were taken with TMS internal standard on the  $\delta$ -scale on a Unity-400+ spectrometer. Mass spectra were recorded on an Agilent Technologies 6420 triple-quad LS/MS mass spectrometer. The course of reactions and purity of products were monitored by TLC on Sigma-Aldrich Silufol L/W plates.

**Bromination reaction of dubamine with N-bromosuccinimide.** 0.185 g (1.03 mmol) of N-bromosuccinimide was added in portions to a solution prepared from 0.2 g (0.8 mmol) of dubamine and 2.4 mL of DMF. The reaction was carried out at a temperature of 50 °C for 6 hours until the initial substance dubamine was completely reacted. The completion of the reaction was determined by TLC, and 30 mL of  $\text{H}_2\text{O}$  was added to the reaction mixture. When the resulting mixture was heated to 30-40 °C, it was observed that the reaction product precipitated. The reaction mixture was then cooled to 10-15 °C in an ice bath and the precipitate was filtered off and washed twice with 20 ml of cold

water. The resulting precipitate was dried at room temperature and recrystallized in alcohol.

Bromination reaction of dubamine with molecular bromine. 0.2 g (0.8 mmol) of dubamine was dissolved in 1 ml of acetic acid ( $\text{CH}_3\text{COOH}$ ) and 0.05 ml (0.96 mmol) of molecular bromine ( $\text{Br}_2$ ) in 0.4 ml of acetic acid was mixed at room temperature. As soon as the solutions were mixed, a precipitate appeared in the reaction mixture, and the resulting precipitate was filtered off. The resulting precipitate was dried at room temperature and recrystallized from alcohol. Melting point (M.p.) 214-215 °C.

2-(2'-Bromo-4',5'-methylenedioxyphenyl) quinoline (bromdubamine 2).  $\text{C}_{16}\text{H}_{10}\text{NO}_2\text{Br}$ . M.p. 132-133 °C (methanol),  $R_f$  0.4.

IR spectrum (KBr,  $\nu$ ,  $\text{cm}^{-1}$ ): 2898, 1615, 1596, 1557, 1497, 1474, 1459, 1425, 1407, 1346, 1317, 1301, 1262, 1240, 1227, 1207, 1129, 1109, 1034, 936, 858, 845, 829.

$^1\text{H}$  NMR-spectrum (400 MHz,  $\text{CDCl}_3$ ,  $\delta$ , ppm, J/Hz): 6.03 (2H, s, 4'- $\text{OCH}_2\text{O}$ -5'), 7.13\* (1H, s, H-3'), 7.13\* (1H, s, H-6'), 7.56 (1H, td, J=8.1, 1.1, H-6), 7.68 (1H, d, J=8.5, H-3), 7.73 (1H, td, J=8.4, 1.4, H-7), 7.85 (1H, dd, J=8.1, 1.0, H-5), 8.15 (1H, d, J=8.5, H-8), 8.18 (1H, d, J=8.6, H-4).

$^{13}\text{C}$ -NMR spectrum (100 MHz,  $\text{CDCl}_3$ ,  $\delta$ , ppm): 158.6 (C-2), 148.8 (C-9), (C-147.9 (C-4'), 147.8 (C-5'), 135.8 (C-4), 135.1 (C-1'), 129.8 (C-7), 129.6 (C-8), 127.6 (C-5), 127.1 (C-10), 126.8 (C-6), 123.1 (C-3), 113.2 (C-3'), 112.9 (C-2'), 111.4 (C-6'), 102.1 (4'- $\text{O}-\text{CH}_2-\text{O}$ -5').

HR-ESI-MS:  $m/z$   $^{79}\text{Br}$ -328.0264,  $^{81}\text{Br}$ -330.0249  $[\text{M}+\text{H}]^+$ , calculated for  $\text{C}_{16}\text{H}_{11}\text{NO}_2\text{Br}$ :  $^{79}\text{Br}$ -328.2700,  $^{81}\text{Br}$ -330.2700.

## Results and discussion

To continue our scientific research and search for biologically active substances with low toxicity, the bromination reaction of dubamine was carried out with N-bromosuccinimide and molecular bromine ( $\text{Br}_2$ ). When molecular bromine ( $\text{Br}_2$ ) was used as a brominating reagent, bromohydrate of dubamine was obtained, and when N-bromosuccinimide was used, 2-(2'-Bromo-4',5'-methylenedioxyphenyl) quinoline (bromdubamine 2) was obtained (see in Figure 2).

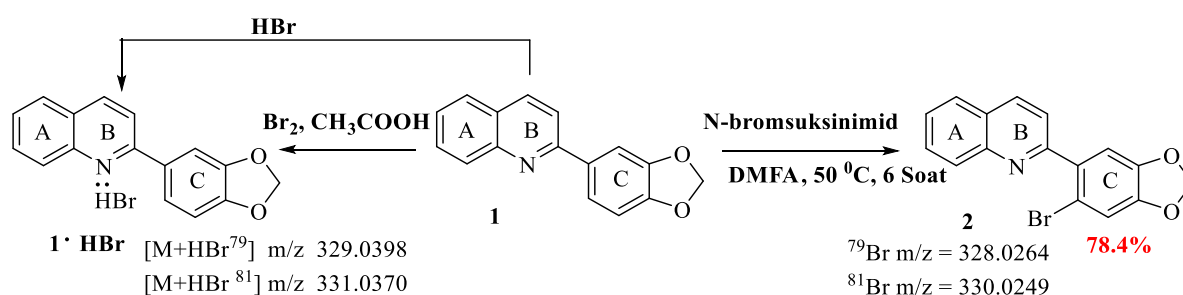

**Figure 2.** Schematic view bromination reaction of dubamine.

The bromination reaction of dubamine in DMF using N-bromosuccinimide was carried out at 50 °C for 6 hours, and after the end of the reaction was determined by TLS, it was possible to isolate bromdubamine 2 with a yield of 78.4%. However, when the solution of dubamine in acetic acid ( $\text{CH}_3\text{COOH}$ ) was reacted with molecular bromine ( $\text{Br}_2$ ), a product with a melting temperature of 214-215 °C was isolated. But, when comparing the NMR spectrum of the obtained product with dubamine 1, it was

found that there are no mutual differences. After that, HBr was added dropwise to the solution of dubamine in acetone, and the precipitated hydrobromide of dubamine was filtered with 1·HBr and the obtained 1·HBr was recrystallized in alcohol. The mixture of 1·HBr with the substance obtained under the influence of molecular bromine did not experience depression at the liquefaction temperature (m.p. 218 °C). At the same time, peaks characteristic of 1·HBr [ $M+HBr^{79}$ ]  $m/z$  329.0398, [ $M+HBr^{81}$ ]  $m/z$  331.0370 were formed in the mass spectrum of the obtained substance. This indicated that dubamine hydrobromide 1·HBr was obtained with molecular bromine.

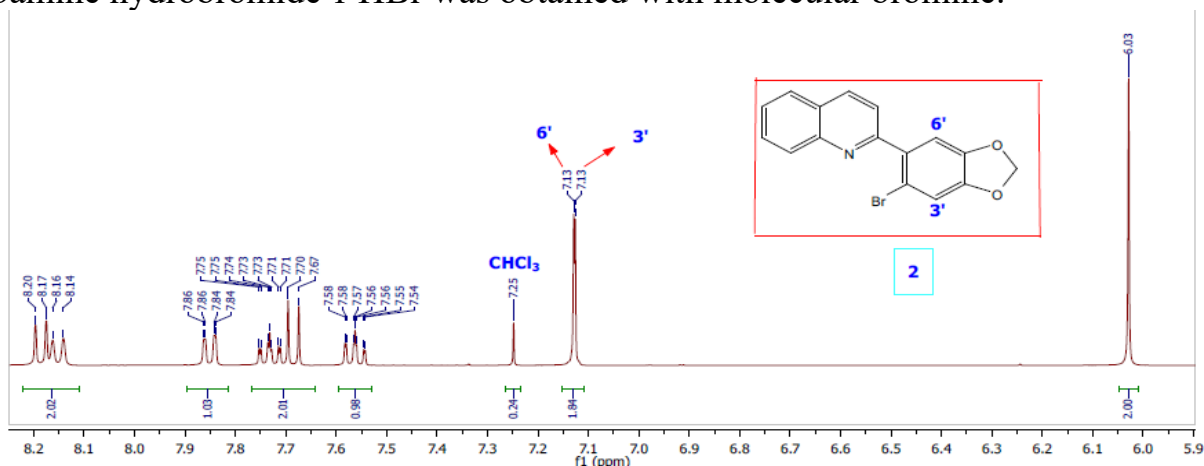

**Figure 3.** PMR spectrum of bromdubamine (2-(2'-bromo-4',5'-methylenedioxyphenyl)-quinoline) 2

The structure of obtained bromdubamine (2-(2'-bromo-4',5'-Methylenedioxyphenyl)-quinoline) 2 was determined using IR, mass,  $^1H$  and  $^{13}C$  NMR methods.

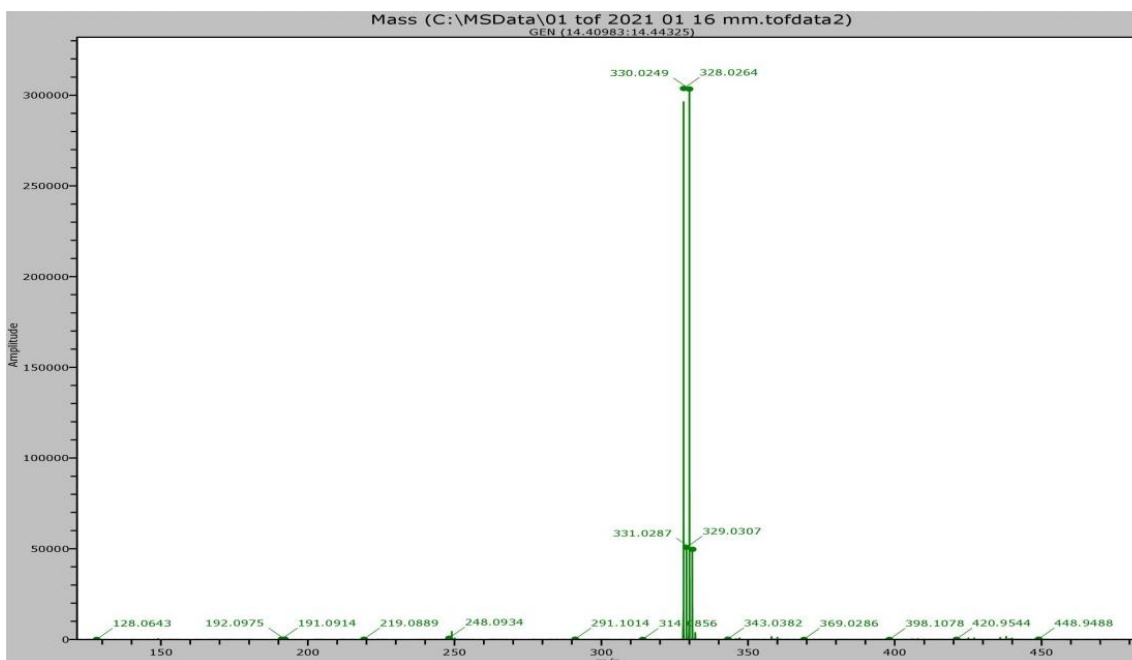

**Figure 4.** Mass spectrum of bromdubamine (2-(2'-bromo-4',5'-methylenedioxyphenyl)-quinoline) 2.

In the IR spectrum of substance 2, the absorption signals related to the valence vibration of the C=C bond of the aromatic ring were observed in the region of 1596-1497  $cm^{-1}$ . The formation of singlet signals characteristic of H-3' and H-6' in its PMR spectrum, the disappearance of doublet-doublet signals characteristic of N-2' in the





dubamine molecule in the 7.62 regions, and the fact that the signal forms of the remaining protons are similar to those of the original molecule indicate that the bromine atom is in the 2' state indicates its connection (see in Figure 3).

As a result of the placement of the bromide (Br) group in the 2' position in the  $^{13}\text{C}$  NMR spectrum of the substance, the signal specific to the C-2' atom is 112.9 m.u. The structure of the substance was proved based on the fact that it was observed in the form characteristic of a quaternary carbon atom and that it was similar to the output areas of other carbon atoms in the original dubamin.

In addition,  $^{79}\text{Br}$ -328.0264 and  $^{81}\text{Br}$ -330.0249  $[\text{M}+\text{H}]^+$  signals characteristic of bromine isotopes such as  $^{79}\text{Br}$  and  $^{81}\text{Br}$  were observed in the mass spectrum of 2. This indicates that one hydrogen atom in molecule 1 has been replaced by a bromine atom (see in Figure 4).

## Conclusion

The bromination reaction of dubamine alkaloid proceeds by the mechanism of electrophilic exchange, and a monosubstituted product is formed. Due to the poor solubility of dubamine hydrobromide in water and glacial acetic acid, bromdubamine is not formed. In addition, acetic acid cannot be used as a solvent for the bromination of compounds containing nitrogen in the heterocyclic ring.

## References:

- [1] Kumar S., Bawa S., Gupta H. "Biological activities of quinoline derivatives," *Mini reviews in medicinal chemistry*, Vol. 9, № 14, 2009, pp. 1648-1654.
- [2] Ubaidullaev A.U. et al. "Intramolecular Cyclization During Bromination of the Quinoline Alkaloid Haplophyllidine," *Chemistry of Natural Compounds*, T. 58, № 6, 2022, pp. 1101-1107.
- [3] Salikhov S.M. et al. "Synthesis of Nitro, Amino, and Halo Derivatives of 2-Ethyl-2-methyl-2, 3-dihydro-1 H-indole," *Russian Journal of Organic Chemistry*, T. 55, 2019, pp. 1539-1546.
- [4] Rahu I., Järv J. "Oxidative bromination of non-activated aromatic compounds with  $\text{AlBr}_3/\text{KNO}_3$  mixture," *Chemical Papers*, Vol. 74, № 4, 2020, pp. 1219-1227.
- [5] Karki M., Magolan J. "Bromination of Olefins with HBr and DMSO," *J. Org. Chem.* Vol. 80, № 7, 2015, pp. 3701-3707.
- [6] Torosyan S. A. et al. "New 4-Substituted 5-(1 H-Pyrrol-2-ylmethyl)-4 H-thieno [3, 2-b] pyrroles and Their Reactions with N-Bromosuccinimide," *Russ. J. Org. Chem.* Vol. 55, № 12, 2019, pp. 1907-1911.
- [7] Negrya S.D. et al. "5-Alkylthiomethyl Derivatives of 2'-Deoxyuridine: Synthesis and Antibacterial Activity," *Russ. J. Bioorg. Chem.* Vol. 46, № 2, 2020, pp. 133-138.
- [8] Muathen H.A. "Mild oxidative bromination of alkenes and alkynes with zinc bromide and lead tetraacetate," *Synth. Commun.* Vol. 34, № 19, 2004, pp. 3545-3552.
- [9] Bastrakov M.A., Starosotnikov A.M. "Synthesis of novel polyfunctional pyrrolo [2, 1-a] isoquinolines based on 1, 3-dipolar cycloaddition reactions," *Russian Chemical Bulletin*, Vol. 68, № 9, 2019, pp. 1729-1734.



- [10] Novichikhina N.P. et al. "Synthesis of 4 H-pyrrolo [3, 2, 1-ij] quinoline-1, 2-diones containing a piperazine fragment and study of their inhibitory properties against protein kinases," *Russ. Chem. Bull., Int. Ed.* Vol. 69, № 4, 2020, pp. 787-792.
- [11] Negrya S.D. et al. "5-Alkylthiomethyl Derivatives of 2'-Deoxyuridine: Synthesis and Antibacterial Activity," *Russ. J. Bioorg. Chem.* Vol. 46, № 2, 2020, pp. 133-138.
- [12] Huang X. et al. "Metal-Free, Regio- and Stereoselective Synthesis of Linear (E)-Allylic Compounds Using C, N, O, and S Nucleophiles," *Org. Lett.* Vol. 17, № 11, 2015 pp. 2594-2597.
- [13] Shakhidoyatov K.M., Mukarramov N.I., Utaeva F.R. "Direction of bromination and nitration of deoxypeganine and its hydrochloride using HPTLC. Synthesis of 6-bromo (nitro)-, 6, 8-dinitrodeoxyvasicinones, 6-nitro (bromo)-, 6, 8-dinitrodeoxypeganines, and 6H (bromo) peganols," *Chem. Nat Compd.* Vol. 44, № 5, 2008, pp. 625-629.
- [14] Kametani T. et al. "Application of the Lewis acid catalyzed [4+2] cycloaddition reaction to synthesis of natural quinoline alkaloids," *Heterocycles (Sendai)*, Vol. 24, № 12, 1986, pp. 3385-3395.
- [15] Ali N.M. et al. "Palladium-catalysed cross-coupling reactions of arylboronic acids with  $\pi$ -deficient heteroaryl chlorides," *Tetrahedron*, Vol. 48, № 37, 1992, pp. 8117-8126.
- [16] Mahanty J.S. et al. "Palladium-catalyzed heteroannulation with acetylenic carbinols as synthons-synthesis of quinolines and 2, 3-dihydro-4 (1H)-quinolones," *Tetrahedron*, Vol. 53, № 39, 1997, pp. 13397-13418.
- [17] Koyama J., Toyokuni I., Tagahara K. "Synthesis of 2-arylquinoline and 2-aryl-4-quinolone alkaloids via Diels-Alder reaction of 1, 2, 3-benzotriazine with enamines," *Chem. Pharm. Bull.* Vol. 47, № 7, 1999, pp. 1038-1039.
- [18] Xi L.Y. et al. "An efficient synthesis of quinolines via copper-catalyzed C-N cleavage," *Org. Biomol. Chem.* Vol. 13, № 13, 2015, pp. 3924-3930.
- [19] Yoon J., Cheon C. H. "Synthesis of 2-Arylquinolines from 2-Iodoanilines and  $\beta$ -Chloropropiophenones via Palladium-Catalyzed Cascade Reaction," *Asian J. Org. Chem.* Vol. 8, № 9, 2019, pp. 1631-1636.
- [20] Naruto H., Togo H. "Preparation of 2-arylquinolines from 2-arylethyl bromides and aromatic nitriles with magnesium and N-iodosuccinimide," *Synthesis*, Vol. 52, № 07, 2020, pp. 1122-1130.
- [21] Niyazmetov A.R. et al. "Synthesis of derivatives of the 2-arylquinoline alkaloid dubamine and their cytotoxicity," *Chemistry of Natural Compounds*, Vol. 56, 2020, pp. 511-517.
- [22] Niyazmetov A.R. i dr. "Sintez 2-(4', 5'-метилендиокси-2'-(п-ариламино)-фенил) хинолинов," *Uzbek Chemical Journal/O'zbekiston Kimyo Jurnalı*, № 3, 2021.
- [23] Niyazmetov A.R. et al. "Amides Based on Fatty Acids and Aminodubamine," *Chemistry for Sustainable Development*, Vol. 29, № 4, 2021, pp. 443-448.