



# ACTUAL PROBLEMS OF MODERN SCIENCE, EDUCATION AND TRAINING

**KHOREZMSCIENCE.UZ**





## CONTENTS

|   |  |
|---|--|
| <b>Section 1. MODERN PROBLEMS OF PHILOLOGY AND LINGUISTICS.....4</b>  |  |
| <b>AKHMEDOVA MEHRINIGOR BAHODIROVNA, DAVRONOVA GULRUH<br/>/// SEMANTIC MECHANISMS OF DYSPEMISM FORMATION AND THE<br/>MAIN CATEGORICAL CONCEPTS RELATED TO THEM.....4</b>  |  |
| <b>FARMONOVA MOHINUR FAKHRITDINOVNA /// A NEW PAGE IN UZBEK-<br/>TURKISH COMPARATIVE LITERATURE: OGUZ ATAY AND NAZAR<br/>ESHANQUL.....11</b>  |  |
| <b>Section 2. ACTUAL PROBLEMS OF HISTORY, PHILOSOPHY AND<br/>SOCIOLOGY.....18</b>   |  |
| <b>GOLIBJON MAHAMMADJANOV /// TENDENCIES OF SOCIAL<br/>CONSCIOUSNESS TRANSFORMATION IN THE PROCESS OF BUILDING<br/>WELFARE STATE IN UZBEKISTAN.....18</b>   |  |
| <b>TAGAYEV KAMOL KAMILOVICH /// SOCIAL DESIGN AND TRAINING<br/>OF MANAGEMENT PERSONNEL.....24</b>   |  |
| <b>Section 3. ACTUAL PROBLEMS OF NATURAL SCIENCES.....29</b>  |  |
| <b>OTAMUKHAMEDOVA GUZAL QAMARADDINOVNA /// SYNTHESIS OF<br/>ACETYLENIC DIOLS BASED ON THE REACTION OF TERMINAL<br/>ACETYLENIC ALCOHOLS WITH ALIPHATIC KETONES.....29</b>  |  |
| <b>ISAYEV DONIYOR TOSHBOTIROVICH, ATAULLAYEV AZIZJON<br/>ODILOVICH, JURAYEV NODIRBEK NORMURODOVICH, OBLOQULOV<br/>JAHONGIR SHAVKAT O’G’LI /// STUDY OF THE STRUCTURE OF THE<br/>NITRIDED LAYER FOR THE STRENGTH OF THE ADHESIVE BOND OF<br/>WEAR-RESISTANT COATING IN R9M4 STEEL.....39</b> |  |
| <b>Section 4. ACTUAL PROBLEMS OF MATHEMATICS, PHYSICS AND<br/>MECHANICS.....46</b>  |  |
| <b>RAKHIMOVA FEROUZA BAXTIYAROVNA /// MATHEMATICAL,<br/>ALGORITHMIC AND SOFTWARE OF THE SYSTEM FOR RECORDING<br/>AND DIAGNOSTIC OF ELECTROCARDIOGRAPHIC<br/>SIGNALS.....46</b>  |  |
| <b>TOKHIROV FERUZ JAMOLIDDINOVICH AND ISROILOVA LOLA<br/>SUNNATOVNA /// INVERSE MATRIX METHOD FOR CALCULATING<br/>MODELS OF STABLE ELECTRICAL SYSTEMS UNDER CONDITIONS OF<br/>INTERVAL DATA UNCERTAINTY.....55</b>  |  |
| <b>ISAKOV ABROR FAKHRIDDINOVICH, NASIROVA SHAIRA<br/>NARMURADOVNA /// MODELING AND OPTIMIZATION OF THE<br/>TECHNOLOGICAL PROCESS OF FLOTATION OF POTASSIUM ORES...62</b>  |  |



**Section 5. MODERN PROBLEMS OF TECHNICAL SCIENCES.....67**

**MEDETOVA KUNDUZ MURATOVNA /// AUTOMATED SYSTEM FOR ASSESSING THE QUALIFICATIONS OF EMPLOYEES IN IT DEPARTMENTS.....67**

**JUMAEV SHERZOD BAHROM UGLI, AKHMEDOVA MUSLIMA DJALALOVNA, TOXTAKXODJAEVA MAFIRAT MAKHMUDOVNA /// IMPROVING METHODS FOR DETERMINING REQUIRED NUMBER OF TRAIN LOCOMOTIVES.....77**

**KHUDOYKULOV ZARIFJON TURAKULOVICH, RAKHMATULLAYEV ILKHOM RAXMATULLAYEVICH, BOYKUZIYEV ILKHOM MARDONAKULOVICH, ALLANOV ORIF MENGLIMURODOVICH /// ANALYSIS OF STREAM ENCRYPTION ALGORITHMS IN eSTREAM PROJECT EASY TO USE IN SOFTWARE FORM.....87**

**BOLTAYEVA SHOKHIDA OLIMJONOVNA /// EFFECTIVENESS OF MODERN EDUCATIONAL TECHNOLOGIES.....96**

**Section 6. ACTUAL PROBLEMS IN MODERN ART AND ARCHITECTURE.....100**

**SADIKOVA ZUKHRA SOTVOLDIEVNA /// DEVELOPMENT OF JAZZ PIANO PERFORMANCE IN UZBEKISTAN.....100**

**SADIKOVA ZUKHRA SOTVOLDIEVNA /// PIANO MUSIC BY COMPOSER NADIM NORKHODJAYEV: PERFORMANCE INTERPRETATION.....104**



## MODERN PROBLEMS OF PHILOLOGY AND LINGUISTICS

UDC: 81.3,81.33,81.37

### SEMANTIC MECHANISMS OF DYSPHEMISM FORMATION AND THE MAIN CATEGORICAL CONCEPTS RELATED TO THEM

**Akhmedova Mehrinigor Bahodirovna**

*Associate professor (PhD),*

*Bukhara State University*

[mexrisha82@mail.ru](mailto:mexrisha82@mail.ru)

**Davronova Gulruh**

*Master student,*

*Bukhara State University*

[amonovkamik@gmail.com](mailto:amonovkamik@gmail.com)

**Annotatsiya.** Ushbu maqolada disfemizmlarning kelib chiqishi nutqda paydo bo'lishi tilshunoslikda o'rganilishi, uning evfemizmlardan farqli jihatlari, semantik jihatdan uning xususiyatlari va o'ziga xosliklari haqida yoritib berilgan.

**Tayanch so'zlar:** disfemiya, semantik ma'no, nutq, konotatsiya, denotatsiya, salbiy ma'no.

**Аннотация:** В данной статье исследуется происхождение дисфемизмов в лингвистике, их отличия от эвфемизмов, их семантические особенности и особенности.

**Ключевые слова:** дисфемия, смысловое значение, речь, коннотация, денотат, негативное значение.

**Abstract.** In this article, the origin of dysphemisms in the speech of people and linguistics, their differences from euphemisms, and their semantic features and peculiarities.

**Keywords:** dysphemism, semantic meaning, speech, connotation, denotation, negative meaning.

### Introduction

Dysphemism's are understudied in the English language. This is especially evident when compared to the amount of available scientific material on the subject of euphemism. Linguistic dictionaries often do not give a separate definition of the concept of "dysphemism".

The "Dictionary of Linguistic Terms" edited by O.S. Akhmanova does not give a detailed definition of this phenomenon either. Here is the entry in the dictionary: "Dysfemismo (dysfemismo) is a trope consisting of replacing the natural in the given context of the subject with something much ruder, familiar or rude; the opposite of euphemism" [1-5].

It can be seen that in the definition proposed above, dysphemism is considered as a stylistic device, while several important aspects of the studied phenomenon, including the semantic component, are not taken into account.



It is clear from the given definitions of the term “dysphemism” that they do not indicate the causes and mechanisms of dysphemism. This situation can be explained chronologically: the term “euphemism” appeared earlier. This may have happened because of society’s centuries-old desire for “politeness”, excessive politeness of speech. That is, dysphemism, a completely opposite feature of speech, was not as attractive an object as in use; interestingly, the topic of euphemism has been devoted to research until now; the number of scientific works will increase significantly. At the same time, the phenomenon of dysphemism itself is as old as euphemism, and its origin dates back to ancient times.

Indeed, in order to provide a satisfactory definition of dysphemism, it seems necessary to study the mechanism of operation of this phenomenon. Nevertheless, pending the results of the work, we will try to interpret this term at least as a first guess: Dysphemism is the process of non-normative naming of the denotation in order to give a negative evaluation and in accordance with the intention of the speaker.

### **Literature Review**

The speaker’s intention to make any dysphemism expression and, accordingly, the purposes he has in using dysphemism. In this regard, we use the concept of “pragmatic precondition” [3-5] introduced by Virgil van Dijk, which is defined as a necessary property of the speech situation. Indeed, the scheme of creating dysphemism presupposes the existence of a basic (initial) context.

Against the background of the dysphemism process taking place in our time, the works of foreign and domestic linguists (S. Vidlak, V.I. Jelvis, A. M. Katsev, E. I. Sheygal, K. Allan, U. Giezek, etc.) appeared, to carry out a sociolinguistic analysis of this lexical layer [2,4]. being done for in the same years, linguists specifically emphasized the peculiarity of modern prose - the saturation of the text with dysphemism’s. In general, we can say that it was in the 20th century that social thinking underwent changes, in its expression, dysphemism’s were far from the last place. He who takes upon himself the burden of the development of industrial society seeks relief in the use of words.

Another historical condition that influenced the number of dysphemistic usages and marked the past, and perhaps the present century, time of freedom of expression is: In the early 20<sup>th</sup> century, most monarchies were overthrown, and even where they were constitutional, monarchies, in particular, appeared in Great Britain, the royal family acquired a purely official status and could not exert significant influence on “dissidents” as before. Thus, along with the kings, centuries of politeness and conservative speech etiquette also passed, which undoubtedly paved the way for the emergence and rapid flourishing of the era of dysphemization of speech. Because of this, there is a need to study this process in modern linguistics, although it cannot be said that the phenomenon has been studied comprehensively so far. Nevertheless, certain shifts occurred, which can be observed, first of all, within the dichotomy “euphemism – dysphemism” recognized today by many scientists (N.S. Yartseva, M.V. Nikitin, A.M. Katsev, V.I. Jelvis, etc.) [3-5,9].

Accordingly, the general speech, discursive and linguistic status of dysphemism changes. Thus, “Euphemisms and Vernacular”. In the article “Semantic aspect”, A. M. Katsev clearly distinguishes between euphemism and dysphemism. He says that dysphemism is not a euphemism for abbreviated style [4,6,8].

### **Research Methodology**

Due to the popularity of the studied phenomenon, it seems possible to talk about dysphemism in modern language speech, which is manifested by the increase in dysphemistic usage.

In our attempts to describe the processes of the emergence of dysphemism, we proceed from two models: pragmatic and cognitivist. The need for such a bilateral alliance is determined by a number of factors:

1. Dysphemism is a purely speech phenomenon. And any statement carries with it a certain intention, which is expressed in the pragmatics of the given statement;
2. Cognitive onset of dysphemism is unquestionable. In general, the cognitive theory of language use, which has been very successfully developed in our time, not only allows us to open access to the processes and structures that determine the emergence of speech acts, but also explains the nature of the relationship between various cognitive phenomena - evaluation, desire, norm, etc. such as. Cognitive science has already explained the integral role of traditional knowledge in speech acts. Such information seems to be very valuable in the study of dysphemism problems.

As mentioned above, the process of forming dysphemism is carried out in different types of communicative actions, and therefore it is logical to distinguish two concepts: the psychological attitude of the addressee and his intention. The first (psychological attitude of the addresser) is characterized by a certain psychological state of the communication participant in the case of dysphemism, which motivates him to use dysphemism.

The context of a dysphemistic sentence means socio-psychological conditions of communicative action, analyzing them, the researcher decides to classify a certain lexical unit as dysphemism.

This context includes the following components:

1. information about the speech act itself and previous speech acts within a particular speech situation. Here, the semantic content of the speech act in the broad sense and the specific meanings of the words in the narrow sense are meant;
2. information of a social nature, including such components as personal information about the participants of the communication (gender, age, etc.); the status of the speakers relative to each other (in the case of dysphemism, the status may or may not be equal, but nevertheless, we are talking about “cultured”, educated persons); the roles of speakers in real situations of depicted communication; functions of speakers (expression, threat, insult, etc.);
3. information of a psychological nature (internal nature of interlocutors); implies the presence of a specific, more favorable psychological state of opponents that provokes the use of dysphemism.

Another historical condition that influenced the number of dysphemistic usages and marked the past, and perhaps the present century, time of freedom of expression is: In the early 20<sup>th</sup> century, most monarchies were overthrown, and even where they were constitutional, monarchies, in particular, appeared in Great Britain, the royal family acquired a purely official status and could not exert significant influence on “dissidents” as before. Thus, along with the kings, centuries of politeness and conservative speech etiquette also passed, which undoubtedly paved the way for the emergence and rapid flourishing of the era of dysphemization of speech.

“Dysphemism is not a type of euphemism, but an antipode. Dysphemism is the opposite of euphemism, but not stylistically, but in an associative-denotative sense”. In other words, dysphemism is not just a reduced stylistic vocabulary, including vulgarisms, slang, and the use of vernacular [6,64]. For these reasons, theoretical in terms, dysphemism is gradually “gaining power” and becoming an increasingly noticeable fact of speech practice and an independent phenomenon that deserves the attention of linguists.

And then a logical question arises: what is included in the dysphemistic vocabulary and where can the boundary between euphemistic and dysphemistic vocabulary be clearly defined?

In our opinion, disagreements on this issue arise when considering the criterion adopted as a basis for comparing dysphemism and euphemism. First of all, it is necessary to agree that talking about dysphemism as an independent phenomenon should be taken as an essence: dysphemism is not a type of euphemism, but its reflection. But dysphemism's are the opposite of euphemisms, primarily not stylistically, but in a denotative-connotative sense. The neutral designation of denotation should be understood as a certain linguistic norm, a stereotype.

## **Analyses and Results**

So, if in euphemism the connotation is ameliorative with negative or neutral denotation, in dysphemism the meaning is neutral or derogatory.

Accordingly, a detailed definition of the term dysphemism, which helps to determine the boundaries and composition of dysphemistic vocabulary, is as follows: dysphemism is the deliberate use of taboo language forms or words in a shortened style, as well as neutral vocabulary. A negative evaluator that does not fit a given speech situation to solve given communicative problems. Such speech situations will be illustrated later with specific examples.

So, let's try to directly understand the semantic mechanism of the appearance and functioning of dysphemistic expressions in speech.

Since all semantic changes, including name changes (semantic changes) are based on formal-logical relations between concepts, semantic changes can be determined primarily based on the types of these connections.

V.G. Gak defines five main relationships between concepts: equivalence (the correspondence of volumes of two concepts); exclusion; opposite; submission or submission; transition [3,7,11]. They correspond to five main semantic processes and types of noun conversion.

1) Equivalence relation corresponds to lexical semantic synonymy. At the semantic level, in this case, all semantic components are preserved, an additional component is added to them (it belongs to the general concept as a specific concept). Synonymous change at the lexical level in speech can be expressed both by synonymous substitution and by replacing a word with a phrase.

2) relationship of migration process, that is, external factors lie within one common concept based on the use of the name of a neighboring concept in the naming of a given concept. At the semantic level, such a name change is interpreted as a change of terms within one semantic category, which leads to the change of members of the semantic paradigm within one lexical-semantic group. Migrations are especially typical of phraseological units, and it is no coincidence that they are a regular method of variant formation.

3) Antonymy is based on opposition relations. At the semantic level, the formation of an antonym can be explained by the replacement of a semantic component with another semantic component with the opposite meaning.

4) Subordination relations of concepts cause two oppositely oriented semantic processes: expansion or narrowing.

Narrowing, on the other hand, is related to the introduction of some components of the same property into the semantic topic.

Broadening in speech results from replacing a word with a narrow meaning, a stylistically or emotionally charged word, with a neutral word. It is easy to assume that narrowing is a reverse process.

5) Intersection relation is the logical basis of transfer process; it exists in two types: transfer by similarity (metaphor) and transfer by neighborhood (metonymy).

At the semantic level, transfer takes the form of erasing or replacing an archiseme while preserving the differential seme, which is the original seme of the name.

The universality of semantic changes based on operations with concepts is confirmed by psycholinguistic experiments, as well as by finding where name changes occur. In fact, when it comes to the semantic connections of words or the replacement of names, the same patterns of change, determined by the logical relations of concepts, appear.

Now we will try to consider which types of semantic relations are characteristic of changes in the framework of dysphemism.

As mentioned, several times above, from the semantic point of view, dysphemism is the process of changing the name, more precisely: the negative naming of the denotation. At the same time, a characteristic feature of dysphemism is the preservation of denotation, that is, a process of change occurs in the connotative component. In the case of dysphemism, the denotation can be negative or neutral.

Let's look at the first option:

1. negative denotation: dysphemism is based on a certain concept, initially evaluated as discriminatory by society. Such concepts include: death, disease, human vices, etc.

Thus, with the help of dysphemism, the speaker strengthens the negative component of this concept. For example, let's take the English word: "prostitute"; the



following slangisms and vulgarisms can be used as potential dysphemisms to express such a social status: “slut, whore, hustler, judy, hackette”, etc.

Also: “fool” – “half-ass, half-cut, mug, muggings, motor mouth, poop-stick” and others; “fuck-up” – “a mess, muddle”; “fairy” – “male homosexual”.

*“The sort of half-assed dottiness they dish out in West End comedies” [7].*

This example is an excerpt from an article devoted to modern film criticism. Taking into account the status of the magazine, vulgarism “halfassed”, “ineffective, inadequate, mediocre; stupid, inexperienced - ineffective, insufficient, average; stupid, inexperienced” serves as the basis for the formation of dysphemism.

*“Middle Britain thinks ... one puff on the joint leads to the needle” [8].*

The explanation of the appearance of dysphemism is represented by the jargon “needle”, which means “a hypodermic needle used for injecting drugs; the use of, or addiction to, injected drugs, addicted to injecting drugs - a hypodermic needle used for injecting drugs” means; injection drug use or drug addiction, injection drug addiction will be similar to the previous one.

The author of the sampled article touches on the current topic of drug addiction, so the use of the aforementioned dysphemism is predictable.

The following cases of dysphemism also raise the issue of addiction to “illegal drugs”:

*“If... he gets high and blurts it out to a stranger in some bar that he got his nickel bag from Joe, the pusher, then Joe's livelihood is endangered”.*

*“Charlie and two fellow “crackheads” took me to a vast housing estate in; South London where crack is on sale for between \$20 and \$25 a deal” [9].*

The form of dysphemism in these examples is the slangisms “nickel” a bag containing, or a measure of, five dollars’ worth of a drug; especially heroin or marijuana - a bag containing, or a measure of, five dollars’ worth of a drug; especially heroin or marijuana; “Crackheads” – “a person who habitually takes the drug crack - usually a person who consumes drugs”, refers to concepts that were initially widely condemned.

*“A creep is a highly expert thief. ... He is so quiet that he can move about the house for hours without waking anybody he can walk around the house for hours” [11].*

In the above example, another area of human vices was touched upon: in the critical article dedicated to the premiere of the play, “crooked - to get drunk” at the New York Metropolitan Opera, where dysphemism is used from 'ed, to fall, to turn off'.

*“Rents as high as \$52 a month for crappy quarters” [12].*

Adjective - vulgarism “crappy” Vulgarism meaning “rubbishly, inferior, worthless, disgusting” is undoubtedly a dysphemism, as used in an authoritative journalistic publication.

*“Between the ages of fifteen and twenty he had been a rent boy, a boy prostitute living and working” [13].*

2. Neutral denotation: the specific concept of dysphemism refers to the neutral. These are: symbols of the nationality of individuals, names of some state institutions, positions or professions, parts of the body, as well as many everyday objects. It should be noted that the second type of relationship within dysphemism distinguishes

dysphemism from euphemism. In the latter, it is known that cases of replacement of meliorative denotation with only meliorative signs have been identified (H. Hi Berdova, L. V. Artyushkina, G. G. Kuzhim, I. P. Pavlova, U. Giezek, etc.). Thus, in the dichotomy “euphemism – dysphemism” defined by the researchers mentioned above, there is a certain shift in the way of formation of these phenomena, that is, dysphemism, in our opinion, is more than from a semantic point of view.

## Conclusions

In fact, it can be seen from many examples that a large number of concepts “fit” with dysphemism. Moreover, this process is not forced, as in euphemism, due to the cultural characteristics of a particular nation, but it occurs due to the pragmatic intentions of the speaker, regardless of the nationality. In this regard, we can say that dysphemism works as an international and widespread phenomenon in modern speech practice.

Based on the above considerations, it can be argued that the very principle of distinguishing the dichotomy “dysphemism-euphemism” is based on the specific generality of the phenomenon - changing or paraphrasing the name due to the pragmatic intentions of the speaker. However, the starting point of this process may not be the same for two events.

Thus, the above-mentioned assumptions about the semantic nature of dysphemism allow us to draw an important conclusion: there are strong grounds for distinguishing between pure (marked) dysphemism and contextually defined dysphemism.

## References:

- [1] Akhmedova M. B., “Analysis and Different Interpretations of the Concept of Spirituality”, *Indonesian Journal of Innovation Studies*, Vol. 18, May 2022, doi:10.21070/ijins.v18i.590.
- [2] Akhmanova O. S., “Dictionary of linguistic terms”, -Moscow city *Nauka*, 1966, p. 376.
- [3] Deyk T. A. Van, “Yaziik. Poznanie. Kommunikatsiya”, Per. s angl./ Sost. V.V. Petrova. -Moscow: *Progress*, 1989, p. 45.
- [4] Vidlak S., “Problema Evfemizma na Fone Teorii Yaziikovogo Polya”, - *Etimologiya*, Moscow: *Nauka*, 1965, p. 167.
- [5] Jelvis V. I., “Pole Brani. Skvernoslovie kak Sotsialnaya Problema v Yaziikax i Kulturax Mira”, -Moscow: *Ladomir*, 2002, p. 349.
- [6] Kasev A. M., “Evfemizmi i prostorechiya. Semanticheskiy aspekt”, - *Aktualniie problemii semasiologii*, L.: *Nauka*, 1991, p.- 237.
- [7] Allan K., “Linguistic Meaning”, London; *New York: Routledge & Regan Paul*, 1986, p.-200.
- [8] Yarseva V. N., “Lingvisticheskiy Ensiklopedicheskiy Slovar”, -Moscow: *Sovetskaya Ensiklopediya*, 1990, p. – 685 (LES).
- [9] Nikitin M. V., “Zametki ob otsenke i otsenochniix znacheniyax – 1”, - *Sb.st. Studia Linguistica, Kognitivno-pragmaticheskie i xudojestvenniie funktsii yaziika*. - SPb.: *Trigon*, 2000, pp. 12-22.
- [10] Black World. Boston. 1. 25.2008.3. Blitz. N.Y. 4.11.2006.



- [11] Observer. N.Y. (8.12.2006; 8.7.1999; 4.11.2001; 5.6.2003; 5.13.2003; 6.11.2004).
- [12] Weekly Guardian. N.Y. 5. 2005.
- [13] Daily Telegraph. N.Y. (4.9.2000; 10.9.2004; 4.6.2005; 6.10.2005; 11.10.2005).
- [14] Ahmedova M. B., “Linguistic Approach to Understanding Spirituality Concept in English and Uzbek”, *Electronic Journal of Actual Problems of Modern Science, Education and Training*, April 25, 2020, pp.127-134.
- [15] Ermetova J., “Principles of Modern Punctuation as a Means of Punctuation to Convey the Semantic Significance of Speech”, *Electronic Journal of Actual Problems of Modern Science, Education and Training*, December 15, 2021, pp. 32-37.

UDC: 8,81-13,821

## A NEW PAGE IN UZBEK-TURKISH COMPARATIVE LITERATURE: OGUZ ATAY AND NAZAR ESHANQUL

**Farmonova Mohinur Fakhritdinovna**

*Doctoral student at the  
Bukhara State University*

[farmonovamohinur91@gmail.com](mailto:farmonovamohinur91@gmail.com)

**Annotatsiya.** Ushbu maqolada bugungi o‘zbek qiyosiy adabiyotshunosligining dolzarb muammolari, o‘zbek-turk qiyosiy adabiyotshunosligi uchun muhim tadqiq yo‘nalishlari borasida fikr yuritiladi. Turk yozuvchisi Og‘uz Atayning “Tehlikeli Oyunlar” va o‘zbek yozuvchisi Nazar Eshonqulning “Go‘ro‘g‘li” romanlarini qiyosiy aspektda tahlil qilish asosida asarlar tegishli bo‘lgan har ikkala adabiyot uchun ham muhim ma’lumotlar beriladi.

**Kalit so‘zlar:** qiyosiy adabiyotshunoslik, komparativistika, struktur tahlil, o‘zbek adabiyoti, turk adabiyoti.

**Аннотация.** В данной статье рассматриваются актуальные проблемы современной узбекской сравнительной литературы, важные направления исследований узбекское-турецкой сравнительной литературы. На основе сравнительного анализа романов турецкого писателя Огуза Атая “Опасные игры” и узбекского писателя Назара Эшонкула “Гёроглы” даются важные сведения для обеих литератур, к которым относятся произведения.

**Ключевые слова:** сравнительное литературоведение, сравнительные исследования, структурный анализ, узбекская литература, турецкая литература.

**Abstract.** This article discusses the current problems of modern Uzbek comparative literature, important areas of research in Uzbek-Turkish comparative literature. Based on the comparative analysis of the novels of the Turkish writer Oguz Atay “Tehlikeli Oyunlar (Dangerous games)” and the



Uzbek writer Nazar Eshanqul “Go’ro’g’li”, important information is given for both literatures to which the works belong.

**Keywords:** comparative literature, comparative studies, structural analysis, Uzbek literature, Turkish literature.

## Introduction

Philosophy, which is the science of understanding existence and humanity, emphasizes the existence of comparison in the essence of any thinking. In fact, all human conclusions - be it scientific or social - rely on comparison. If we look at it from this point of view, the comparative study of literature in modern philology is one of the current trends. Because the essence of existing things and events is revealed through comparison, so literary events, literary periods, and most importantly, artistic works should be given a truly objective assessment through comparison.

## Literature Review

It is known that comparative literature appeared for the first time in the world scientific process at the beginning of the 19th century (1817) in France with the term “*littérature compare*”. literary reception (the process of receiving other people's literature), which has advanced consistently and rapidly under the influence, has led to the formation of comparative literary studies as an independent science with its own laws, rather than a specific branch of science [1].

Comparative literary studies - literary comparativistics, which studies the literature of peoples with universal history, universality, peoples belonging to different places and times, or peoples that are completely unrelated to each other either genetically, geographically, or linguistically, as the object of its research - literary comparativistics are becoming globalized today, is a field of science that is gaining deep importance in the integrating world.

## Research Methodology

*Comparative literary studies in Uzbek literary studies.* In modern Uzbek literary studies, the weight of sources and scientific researches related to comparative literary studies has been increasing in recent years, which is a gratifying phenomenon for our literary studies. Uzbek comparative literature has been growing since the middle of the 20<sup>th</sup> century. But since the researches carried out during this period were based only on Russian literature and world literature translated through the Russian language (experts in the field know well that the translation of a translation is like a soup of a soup, it leads to the loss of subtleties of meaning in the original text, to a far distance from the original is reason enough) it was difficult to see the variety.

The improvement of international relations after independence also played an important role for scientific and literary relations. In our literature, the number of direct translations from the native language has increased. In the translation, not only Western literature, but a new world for Uzbek readers, Uighur, Chinese, Korean, Japanese, Scandinavian, etc., were translated [2, 3]. In the same process, many readers who consider Turkish literature to consist of Aziz Nesin's stories and “Choliqushi” (Rashad Nuri Guntekin) began to enjoy the colorful world of Turkish literature. During the

colonial period, the literature of the brotherly Turkic peoples was not studied much, because it was not allowed to unite the nations with the same past and the same pain in the literature. Today, the whole Turkic world is united around noble goals. Of course, on this path, literature has a leading position and a fixed place.

At this point, we found it appropriate to quote the following quote from the work “Karşılaştırmalı Edebiyat (Comparative Literature)” by the French scientists A.M. Rousseau and K. Pishua, translated into Turkish by the translator Mehmet Yazgan:

**“Karşılaştırmalı edebiyat; analoji, akrabalık ve etkileşim bağlarının araştırılması suretiyle, edebiyatı diğer ifade ve bilgi alanlarına ya da zaman ve mekan içerisinde birbirine uzak veya yakın durumdaki olaylarla edebi metinleri birbirine yaklaştırmayı amaçlayan yöntemsel bir sanattır. Yeter ki bu edebi metinler birçok dile ya da kültüre ait olsunlar; onları daha iyi tanımlayıp anlamak ve onlardan zevk alabilmek için aynı geleneğe ait bulunsunlar” [2].**

*“Qiyosiy adabiyotshunoslik o’xshashlik, qarindoshlik va o’zaro ta’sir rishtalarining tadqiq qilinishi shakli bilan adabiyotni boshqacha ifoda va bilim sohalariga yoki adabiy matnlarni zamon va makon doirasida bir-biriga uzoq yoxud yaqin bo’lgan hodisalar bilan o’zaro yaqinlashtirishni maqsad qilgan uslubiy bir san’atdir. Bu adabiy matnlar bir necha tilga yoki madaniyatga oid bo’lsa ham, ularni ta’riflash, yaxshiroq tushunish, ulardan zavqlana olish uchun bir xil an’anaga tegishli ekanliklari yetarlidir”.*

*“Comparative literature; It is a methodological art that aims to bring literature closer to other fields of expression and knowledge, or to bring literary texts closer together with events that are distant or close to each other in time and space, by investigating the ties of analogy, kinship and interaction. As long as these literary texts belong to many languages or cultures; Let them belong to the same tradition in order to better define and understand them and to enjoy them”.*

In our opinion, this is a definition that covers the entire field of comparative literature. It is very important to correctly and appropriately understand the word “tradition” at the end of the definition before analyzing this idea. If we understand this word as culture, we will witness the completely opposite definition of comparative literary studies. But if we can understand this word as value - universal, worldly values, we will reach the real essence. Because the purpose of comparative literature studies is to compare and study any literary texts regardless of time and place, to study their differences and similarities, their strengths and weaknesses. Only the values and traditions of the works that will be the object of research should be compatible: if one depicts human freedom as a normal and natural state, while the other glorifies individual freedom, then how can these works be compared?!

Therefore, it is appropriate that the works of art that will be the source of research for comparative literature should be within the framework of immortal themes, living ideas and views relevant for all times and places recognized in world literature.

## **Analysis and Results**

*Uzbek-Turkish comparative literature.* Based on the general information given above about literary events and works that can be compared, I would like to draw your

attention to Uzbek-Turkish comparative literature as an important direction of today's Uzbek comparative literature. As we noted at the beginning of the article, today's Uzbek comparative studies has not yet been fully formed on the basis of clear methodological principles. For this reason, unfortunately, we cannot find any textbooks, monographs or methodological manuals under the name of

However, the fact that various scientific works, dissertations, and articles related to the field are being written and researches are being conducted in the following years is a proof that this direction of our literary studies is also in the process of development. Hoping to make a worthy contribution to this process, we chose the works of Turkish writer Oguz Atay and Uzbek writer Nazar Eshanqul to study Uzbek and Turkish literature in a comparative aspect [4].

First of all, it is necessary to emphasize that the Turkish and Uzbek peoples have a historical root, brotherhood, language, belief, and values, which are similar and united. As the subjects of our comparison, we chose Oguz Atay's "Tehlikeli Oyunlar" ("Dangerous Games" - the translation is ours) and Nazar Eshanqul's "Go'ro'g'li" novels. Now we will try to answer the question of what are the common and different aspects of these two works to the best of our ability:

#### *1. The dominant literary trend in the works.*

Oguz Atay's novel "Tehlikeli Oyunlar (Dangerous Games)" was written in 1973 and is the second major work of the author. Before that, the novel "Tutunamayanlar" ("Those who could not save" - the translation is ours) was published, and with this work, the writer fully expressed postmodernism in Turkish literature. Because the era of the Republic created by Oguz Atay was the stage of transition from modernism to postmodernism. Atay's novel "Tehlikeli Oyunlar (Dangerous Games)" has the status of a postmodern work, as it is written against the evils of the modern world in a sarcastic, ironic way, and expresses the original life and dream at the same time [5]. Although Nazar Eshanqul's novel "Go'ro'g'li" was written in the 90s of the last century, it was repeatedly edited by the author under the influence of a feeling of dissatisfaction, and finally, as the writer himself noted, "only to be a small lesson to be learned from the autocratic regime, which failed to prove its existence and existence, lived at the expense of humiliating and humiliating the honor and pride of man" [5, 6] was published as a book in 2018. The 1990s were a period of transition, when modernist views gradually began to enter Uzbek literature, and small debates and disputes arose between representatives of traditional traditions and supporters of modernism. The novel "Go'ro'g'li" written in the same period can be evaluated as a work that can fully demonstrate the characteristics of modernism.

Because the novel is about the insignificance of space and time lines, the twisting of events from the usual flow to an absurd one that overturns human life, and the twist that leads to tragedy despite the efforts made to regulate it, and finally, from the search for logic among illogicalities. proves the above point with aspects such as the tired hero's later acceptance of this tragedy as a measure.

Although these two works belong to two different streams, such as postmodernism and modernism, in terms of literary flow, it is worth saying that these two streams are mutually exclusive, and at the same time, postmodernism cannot exist without the

foundation of modernism, so they are mutual. can form a commonality in a certain sense with its connection.

### 2. *The period in which the works were written.*

As we mentioned above, “Tehlikeli Oyunlar (Dangerous Games)” is a work of the 70s of the last century. And this period is considered the second stage of the Republic period in Turkish literature. The 70s are characterized by the gradual transition of modernism to postmodernism in Turkish literature, and the work of Oguz Atay is very important in this process. Because it was this creator who caused the postmodernist thinking to take root in Turkish literature with his novels (“Tutunamayanlar”, “Tehlikeli Oyunlar”) [7].

If we pay attention to the fact that the novel “Go’ro’g’li” was written in the early 1990s, we can see that it is one of the first works of the Independence period.

Of course, there are certain similarities and differences between this novel and Oguz Atay's “Tehlikeli Oyunlar (Dangerous Games)” novel, which was born as a product of renewed thinking in the new era. In Turkish literature, “Tehlikeli Oyunlar (Dangerous Games)” belongs to the 2<sup>nd</sup> stage of the Republic period, and in Uzbek literature, “Go’ro’g’li” is different from the 1<sup>st</sup> stage of the literature of the Independence period. But both works have something in common in terms of renewed consciousness [8].

### 3. *Symbolism.*

There are common criteria in both works that not only every image, but also every detail in the flow of the subject has a symbolic meaning, expresses symbolic concepts, and these symbols have a narrative character. But considering the size of the article, we will consider this symbolism only within the headings:

“Tehlikeli Oyunlar (Dangerous Games)” - as soon as the reader sees the title, he imagines a mysterious, mysterious subject, a detective journey; but this title refers to the games of life that every person experiences and endures in his ordinary life, which he is sure to face, and even most likely lives in this situation, so that the reader throughout the pages of the work, the life itself is actually very it is a dangerous game and we all realize that we are sometimes talented and sometimes incompetent players who are condemned to play certain roles in this game, unfortunately there are more losers than winners in this game [9]. During the work, one can come across the author's overt and hidden comments about this fact many times.

“Go’ro’g’li” - why did this name, which was not mentioned once in the work, become the title? As readers, each of us strives to get at least a little information about the work through the titles, but unfortunately, this desire cannot overcome the barriers of symbolism. Because a symbol is a code. According to the approach of structural analysis, symbols in a literary text are coded words. The true essence of the text is revealed in the process of deciphering these codes. Of course, this is a complex analysis process and it is difficult to express it within the framework of one article. But here it is worth noting that structural analysis is effective for works where such symbolic expression prevails. As part of the research work, we analyzed the title of the novel “Go’ro’g’li” using the method of structural analysis and published our conclusions as an article [10]. Here we make some conclusions.

It is known that Go'ro'g'li is the name of the main character of a popular epic among Turkic peoples who was born in a grave and spent his childhood in a cemetery. So, what is the connection and similarity? On what analogical or metaphorical basis did the author name the title of the work after the hero of this epic? To get an answer to this question, you need to read the entire text of the work. In fact, this is the intention of the author. It is actually a great literary skill to present the title in the form of an interesting puzzle. The reader goes after this puzzle and reads the entire work, and gradually begins to find the solution scattered in the depths of the pages. Not in a dark pit like Go'ro'g'li, but darkness like a pit was born in an environment, grew up in this environment [6]. In this name, there is a reference to the person who must come out of this darkness to the light with his will, perseverance, and determination. Although at the end of the story, the hero of the work is tired both mentally and physically from fighting against injustice and decides to condemn himself to nothingness, but the title of the work is when the people condemned to captivity will be a support for their Go'ro'g'lis. He emphasizes that if he can be a support, he will definitely achieve freedom.

So, while both titles are similar in their narrative symbolism, they differ sharply in the way they are addressed throughout the work.

There are a number of other literary elements that are important to compare on the scale of both works, each of which can be a worthy topic for research. For example:

- the symbolism in the names of characters in the works, the oxymoronic approach in the names (in "Tehlikeli Oyunlar (Dangerous Games)", Hikmet Benol's search for the wisdom of life throughout his life, but not finding it; and as Benol, he cannot find his "I", cannot be me; Love's compulsion to love; Bilge's Bilge- not being able to understand Hikmet as a sage; abandoning N. in one minute with inappropriate devotion to Eve's name in "Go'ro'g'li" v.h.);

- the use of abbreviations (H. in "Tehlikeli Oyunlar (Dangerous Games)"; N. in "Go'ro'g'li");

- sharp conflicts in the triad of **man-personality-society** (in "Tehlikeli Oyunlar (Dangerous Games)" personality and self are more important in this triad, in "Go'ro'g'li" society is more important);

- at the end of the play, the choice of death is accepted as the last measure; but in "Go'ro'g'li" of this ending, the absolute ruler typical of modernism is an absurd system in society; In "Tehlikeli Oyunlar (Dangerous Games)" the postmodern interpretation of a person as an existing person, as a rebellion against not being accepted by others;

- in both works, very little space is allocated to the landscape, and through this, a person is depicted not as a part of nature - a natural being, but as a social being whose natural needs are violated;

- how the national culture is reflected in the works, linguoculturology;

- existence of cross-cultural similarities and differences.

The fact that this series can be continued proves that comparative literary studies can give excellent conclusions not only about the works in comparison, but also about entire literatures and literary periods through them.



## Conclusions

In conclusion, it should be noted that today's Uzbek comparative literary studies must have the status of an independent science, which has its own principles, like French comparative studies, English comparative studies, and Russian comparative studies. Naturally, research in this direction is of great importance for this. The more thorough research and scientific research in the comparative aspect, the more the methodological foundations of the field will be strengthened, and the ground for development will be created. Therefore, Uzbek-Turkish comparative literature as a branch of this field of science deserves special attention. As you can see in the analysis, based on the works of Oguz Atay and Nazar Eshanqul, comparing a certain period of literature of two countries, society and human relations, the stages of development in literature, it is important for both Uzbek literature and Turkish literature. scientific conclusions can be obtained. Therefore, the evaluation given to the literary text in the comparative aspect is the true and objective scientific truth that can be said about the work.

## References:

- [1] Kasimov A., Hamrokulov A., Khojayev S., “Comparative literary studies”, Tashkent, 2019.
- [2] Rousseau A., Pichois Cl., “Karşılaştırmalı Edebiyat”, Ankara, 2022.
- [3] Farmonova M., “Text title as the main object in structural analysis”, *BukhSU Scientific Bulletin*, Issue 8, 2023.
- [4] Muhammadjon H., “Landscapes of modern literature of the 20<sup>th</sup> century”, Tashkent, 2020.
- [5] Müberra Dinler, Oğuz Atay’ın Edebi Metinlerinde Ana İzlekler ve Yazarın, “Türk Edebiyatı İçindeki Yeri”, *Yüksek Lisans Tezi*, İstanbul, 2014.
- [6] Nazar Eshanqul, “Go’ro’g’li”, Tashkent, 2018.
- [7] Og’uz Atay, “Tehlikeli Oyunlar”, İstanbul, 2022.
- [8] Semih Gümüş, “Modernizm ve Postmodernizm”, İstanbul, 2021.
- [9] Fitria Nur Hasanah, Rahmania Sri Untari, Shofiyah Al Idrus, and Akhmedova Mehrinigor Bahodirovna, “Excel in Critical and Creative Thinking in Object-Oriented Programming”, H. Ku et al. (Eds.): *ICARSE, ASSEHR 748*, 2023, pp. 301–305.
- [10] Hazim H., Ratih P.A., Mehrinigor A.B., “Altruistic Actions in COVID-19 Corpses Care: Empathy, Modeling, and More”, *International Conference on Advance Research in Social and Economic Science (ICARSE 2022)*, 2023, pp. 476-484.



## ACTUAL PROBLEMS OF HISTORY, PHILOSOPHY AND SOCIOLOGY

---

UDC: 308,311,378

### TENDENCIES OF SOCIAL CONSCIOUSNESS TRANSFORMATION IN THE PROCESS OF BUILDING WELFARE STATE IN UZBEKISTAN

**Golibjon Mahammadjanov**

*Head of the department of Social Legal  
Media Center of the Oliy Majlis of the  
Republic of Uzbekistan, doctor of  
philosophy in political sciences (PhD),  
[galibmahammadjanov@gmail.com](mailto:galibmahammadjanov@gmail.com)*

**Annotatsiya.** Maqolada yangi zamonaviy munosabatlarda demokratik tamoyillar asosidagi jamiyat va davlat qurish bilan bog'liq jarayonlarda ijtimoiy ong va unga ta'sir etuvchi jamiyat institutlarining ahamiyati, fuqarolar va jamiyat munosabatlarida kuzatiladigan transformatsion o'zgarishlar, ularning zamonaviy jamiyatlardagi ijtimoiy tizimi rivojidadagi ahamiyatining konseptual asoslari o'rganilgan. Shuningdek, rivojlangan xorijiy davlatlar, dunyoning yetakchi ilmiy tadqiqot institutlari va markazlarida zamonaviy jamiyatning siyosiy institutlari faoliyatini yanada modernizatsiyalash hamda ularni ahamiyatini oshirishga qaratilgan o'rganishlar asosida "xalqparvar davlat" qurish jarayonida ijtimoiy institutlarning ahamiyati masalasi alohida tahlil qilingan.

**Kalit so'zlar:** ijtimoiy institutlar, xalqparvar davlat, ijtimoiy davlat an'anaviy jamiyat institutlari, zamonaviy jamiyat institutlari, transformatsiyalashuv, strategiya, ijtimoiy ong, siyosiy faollik, madaniyat, ijtimoiy-siyosiy munosabatlar.

**Аннотация:** В статье рассматривается значение общественного сознания и влияющих на него социальных институтов в процессах построения общества и государства, основанного на демократических принципах, в новых современных отношениях, трансформационные изменения, наблюдаемые в отношениях между гражданами и обществом, а также концептуальные основы их значения. в развитии социальной системы в современном обществе. Также отдельно проанализирован вопрос о значении социальных институтов в процессе построения «народно-ориентированного государства» на основе исследований, направленных на дальнейшую модернизацию деятельности политических институтов современного общества и повышение их значимости в развитых зарубежных странах ведущие мировые научно-исследовательские институты и центры.

**Ключевые слова:** социальные институты, дружественное народу государство, социальное государство, институты традиционного общества, институты современного общества, трансформация, стратегия,



общественное сознание, политическая деятельность, культура, общественно-политические отношения.

**Abstract:** The article discusses the importance of social consciousness and social institutions affecting it in the processes of building a state on democratic principles in new contemporary relations, the transformational changes observed in the relations between citizens and society, and the conceptual basis of their importance in the development of the social system in modern societies. Also, the issue of the importance of social institutions in the process of building a welfare state was separately analyzed on the basis of studies aimed at further modernizing the activities of political institutions of contemporary society and increasing their importance in developed foreign countries, the world's leading scientific research institutes and centers.

**Keywords:** social institutions, people's state, social state, institutions of traditional society, institutions of contemporary society, transformation, strategy, social consciousness, political activity, culture, political and social relations.

## Introduction

On April 30, 2023, a referendum was held in our country on an important political process - a new draft of the Constitution. As a result, the new version of our Constitution was adopted and Uzbekistan strengthened the status of a social and secular state. In its content, the goal of establishing a welfare state in the New Uzbekistan is indicated. "Along with all walks of life of the nation, it requires fundamental change in the mindset and outlook of citizens" [1] - said Sh. Mirziyoyev. The purpose of this is to establish a welfare state in the New Uzbekistan.

## Literature review

In contemporary society, law and order are as divine as human faith [2]. In our opinion, a democratic state is primarily the operation of a government system that serves to safeguard human dignity at a high level. Building a welfare state can be seen as a consequence of modern, new democratic political relations. In particular, modernity in the political sense is the state of active participation of citizens in political life, increasing the interest in changing it, modernization of society [3]. In political science, there are varying views about the construction of such a state and about its necessity. In particular, there are notions such as the democratic accountability of the government to citizenry [4], the responsibility of managers to their subordinates, and the state's responsibility to the population [5]. In our opinion, it is correct to say that a welfare state is a legitimate form of the principal institutions of society that fully express the interests of the people. The direct connection of the concept of a welfare state with social institutions is seen in the fact that they are a set of mechanisms designed to add up to the popularity of this state. In particular, one can observe that another indication of such construction of state is the formation of an atmosphere of infatuation and transparency in society. Since the beginning of democratic laws in the world, states and societies have reflected one or another aspect of building a welfare state based on actions designed to convey the interests of citizens to the fullest extent

possible. For example, in the program of F. Roosevelt in the United States, in the paragraph on the issue of social security of the population, it was shown that the establishment of the “welfare state” (social state) is the main principle of the democratic system [6]. In fact, the purpose of the organization of politics and political institutions is aimed at the formation of a developed political system based on the protection of the interests of citizens. “If the last goal of all sciences and arts is welfare, then the most basic and priority goal of all sciences and arts, especially politics, is higher welfare”. The main problem is the formation of mechanisms for its implementation. It should be recognized that each country achieves this based on the implementation of its own political measures (given the universal democratic principles - the author).

### **Research Methodology**

A welfare state is explained by the level of catering to the principles of legitimacy in society. In this case, the highest authority and supremacy of the national legislation should be ensured [6]. As the objects of the formation of this kind of state and polity, political institutions come into the field. It is important that political institutions become the main driver of preparing citizens for any changes in modern political views and relations (political propaganda). First of all, it coincides with the rejuvenated society and the views of the latest generation (built on the change of social consciousness). On the basis of such realities, political conflicts can be observed with some sort of certainty. In the modernizing societies, there are conflicts between rationalism and rationalism and traditional way of life and way of thinking [6].

### **Analysis and Results**

The need for a welfare state in Uzbekistan was explained by Uzbekistan’s President on 19 September 2017, during the 72nd session of the United Nations General Assembly, who announced a new level of reforms aimed at cardinally renewing the life of the nation, delivering a new, democratic perception of the Uzbek society [7]. The main content of building a New Uzbekistan – welfare state was explained by the President Sh. Mirziyoyev, “In the current conditions where various threats against peace and stability have been mounting in the globalized world, transformation in the life of the people and level of their spiritual development, the execution of general laws specific to this process and thereby it is necessary to pay special attention to specific country characteristics” [8]. It would be apt to say that the New Uzbekistan is the full expression of a welfare state to national and world standards. On the basis of the idea of building such a state along with the role of such political institutions is that they are able to determine the next level of the development of the society step by step, and to ensure that the current changes are adequate and up to the point. “It is essential to continuously perfect our work methods and indicators of our activities in accordance with the socio-political architecture of contemporary era, the formation and establishment of new systems and structures”, says our President [9]. In the new society, in the conditions of the liberalism of free thought, ideas, views, ideologies, transforming the political inclination of citizens to support the government, shaping mutual confidence between the state and society, not only by the state, like in the

traditional society, but also by the people the responsibility of ensuring complete and free proactive participation also rests with political institutions. Especially in the growing societies and states, in case such political relations are not guaranteed, the confidence between the state and citizens will disappear, while the government can likely lose its political participants. In our view, the need for political institutions in contemporary societies is to shape, develop and direct the pluralist mood in the society. The crisis of political institutions that fail to include the development of political pluralism is inevitable. This is one of the principal political characteristics of a welfare state. “Pluralism, i.e. diversity of opinions and views, is unique to an enlightened, modern society” [8]. In the process of building a democratic society, the issue of stability is also the major indicator of the its future polity. The basis of this stability depends directly on the activness of political institutions. This is one of the key factors that come to be important in the life of countries bent on constructing a new state or renewing it. “Built on world experience, it can be said that a certain level of rational bureaucracy is an essential condition for modernization, one of the objective laws in this process”. To protect the general public from ideologies of previous regimes, as well as from the tyranny of the ideas of the modern age (mass culture, pluralism, etc.), to preserve its values and customs in accordance with the norms of society, and to pass them on to the next generation is one of the problems under constant attention. Political institutions execute the task of ideological and spiritual guardians in the sense of uniting the members of a society. This idea is based on the shared commonality of values, traditions and customs typical of that society and state. However, the study of traditional institutions of society and their essential aspects as bases of any modernity is an crucial turning point in the history of statehood. In our view, in the process of building a welfare state, it is critical to take into account two essential factors before the state and society that have embarked on changes, and they are closely related to each other: a) changing the level of social consciousness in society; b) development of activities of the principal institutions of the society.

Strengthening the principle of “New Uzbekistan as a social state” in our General Law, ensuring that human interests are the main criterion in the process of various reforms, inviolability of private property, land ownership, raising the place of civil society institutions to the constitutional level, state power shows the urgency of improving the basics. Several amendments and additions have been made to our constitution. But they were mainly related to the activities of the authorities. At the core of the current amendments and additions is the idea of “Human dignity”, i.e. the amendments and additions provide for the constitutional and legal guarantee of robust protection of human rights and freedoms in Uzbekistan. The need to amend the principle of “state-society-man” to “man-society-state” paradigm became an important basis of constitutional reforms. In our view, in the conditions of contemporary democratization and globalization, in ensuring the practicality of establishing a welfare state in the New Uzbekistan, the significance of political institutions will be higher than ever, because in the 21<sup>st</sup> century, in a time when the grade of human thought and worldview have been changing every hour, old and new unification, strengthening of the socio-political structure of the state and society is expressed as a constant essential



criterion in the construction of statehood. In its content, the goal is to establish a social state in the New Uzbekistan. In the contemporary society, it is understood that in its essence, law and order are considered as sacred as the human faith.

There are different views in social sciences about the construction of such a state and its crucial necessity. In particular, there have been such views as the democratic accountability of the government to citizens, the responsibility of the managers to subordinates, and the responsibility of the government to the population. In our view, it would be apt to say that the social state is a legal form of expression of the interests of the people (citizen, electorate) by the principal institutions of society.

The direct connection of the concept of the social state with political institutions is seen in the fact that they are a set of mechanisms designed to increase the popularity of this state. Therefore, another sign of the construction of such a state is the formation of infatuation and transparency in society.

Ever since democratic laws began to apply in the world, states and societies have reflected one or another aspect of building a social state on the basis of actions aimed at expressing the interests of citizens to a full extent. As the new Uzbekistan aims to build a constitutional democratic state and free civil society, the process of de-statistic, i.e. reduction of government intervention, decentralization, i.e. decentralization of the activities of state authorities will grow from statist principles of public administration. It is preferable to carry out reforms in the form of modernizing the political system in Uzbekistan by relying on the traditional foundations of political institutions and adapting them to the new processes. In this, it is aimed at the implementation of the state and society building, given the contemporary political, social and spiritual relations specific to Uzbekistan, on the basis of the improvement of government bodies, and it is also shown as the foundation of civil society. The process depends on new transformation in all walks of society and mechanisms for improving the willingness of society members and its key political institutions. The modernization of political institutions goes hand in hand with decentralization of power structures (that is, decentralization) and wide involvement of citizens in socio-political relations. In particular, the decentralization and adaptability appear as two components of a single political relationship from political institutions. Therefore, the state of the decentralization process, the extent to which it corresponds to the political outlook and views of its participants, is expressed by the outcomes of the political institutions on their influence. One of the key reasons why democracy, recognized as the principle of universality, has a different appearance and results in the relations of sociopolitical development of various countries can be determined by the fact that their society and its main institutions are in a bad mood, and second, by their generally less effective activity.

## **Conclusions**

In conclusion, one can emphasize that the principal institutions of society in the New Uzbekistan, in the execution of tasks such as establishing a welfare state, are the key space in the shaping of a generation of citizens with the ability to think aptly and independently, about society and the state. They are also the major workers in this. If



this job is delayed, the level of perceptions about other areas of society development and its institutions will be narrowed.

Second, the polity itself should be willing for modernization, and it should be able to accept the characteristics of self-renewal and transformation. Only then will it start to produce results. On the basis of permanent social, economic, and political reform, a tendency and support for transformation was formed among the population.

Therefore, modernization changes are first of all based on the readiness of principal institutions of society and state, that is, on the basis of ensuring the degree of awareness of citizens about it, and as a consequence, it ensures its practicality. The direction of the development of modern relations in the life of a particular state and society depends primarily on the transformation of their political institutions. "The current new development of Uzbekistan requires a cardinal transformation of approaches on this front.

### References:

- [1] Mirziyoev Sh., "Yangi O'zbekiston strategiyasi", -Tashkent: *Uzbekiston*, 2021, p. 8.
- [2] Qodirov A., "Mamlakatni modernizatsiya qilishning strategiyasi", -Tashkent: *TDYuI*, 2006, p. 13.
- [3] Qodirov A., "Mamlakatni modernizatsiya qilishning strategiyasi", -Tashkent: *TDYuI*, 2006, p. 8.
- [4] Xeld D., Goldblatt D., Makgrю Э., Perraton D., "Globalniie transformatsii: Politika, ekonomika, kultura", -M.: *Praksis*, 2004, pp. 54 – 55.
- [5] Daymond L. Proshla li., "Tretya Volna demokratizatsii" *Polis*, № 1, 1999, pp. 10 – 25.
- [6] Wikipedia. A.V.Dicey. URL: [http://en.wikipedia.org/wiki/A.\\_V.\\_Dicey](http://en.wikipedia.org/wiki/A._V._Dicey)
- [7] "O'zbekiston Respublikasi Konstitutsiyasi", -Tashkent: *Uzbekiston*, 2008, p. 3.
- [8] Mirziyoev Sh., "Yangi O'zbekiston strategiyasi", -Tashkent: *Uzbekiston*, p. 8.
- [9] Mirziyoev Sh., "Yangi O'zbekiston strategiyasi", -Tashkent: *Uzbekiston*, p. 12.
- [10] Levitin L., "O'zbekiston tarixiy burilish pallasida", -Tashkent: *Uzbekiston*, 2001, p. 344.



UDC: 308,316.3,37.01

## SOCIAL DESIGN AND TRAINING OF MANAGEMENT PERSONNEL

**Tagayev Kamol Kamilovich**

*Researcher at Navoi State*

*Pedagogical Institute*

[nigina11@mail.ru](mailto:nigina11@mail.ru)

**Annotatsiya.** Muallifning soʻzlariga koʻra, ijtimoiy loyihalar oʻz maqsadlarini va ushbu maqsadlarga erishishning eng yaxshi usullarini aniq belgilaydi, bu loyihaning muvaffaqiyatga erishish imkoniyatlarini oshiradi. Maqolada ijtimoiy loyihalarning ahamiyati ochib berilgan. Agar biz ijtimoiy loyihalarning turli shakllarini farqlay olsak va ushbu ijtimoiy loyihalarning taʼsirini baholay olsak, biz loyihalarni institutning kuchli tomonlariga moslashtirish va jamiyatning koʻproq manfaati uchun ishlash uchun yaxshi holatda boʻlamiz. Falsafiy tahlilning mohiyati chuqurroq tushunish va kelajakdagi ijtimoiy loyihalar bilan moslashuvchan tajribalar uchun asos yaratishdir.

**Kalit soʻzlar:** yetakchilik, strategiya, tuzilma, jarayon, fikrlash, loyiha boshqaruvi, ijtimoiy loyiha, jamoa, jamiyat, ijtimoiy, loyiha, kadrlar.

**Аннотация.** По мнению автора, социальные проекты четко определяют свои цели и наилучшие пути достижения этих целей, это увеличивает шансы проекта на успех. В статье раскрывается значение социальных проектов. Если мы сможем различать различные формы общественных проектов и оценивать влияние этих общественных проектов, тогда мы сможем лучше сопоставлять проекты с сильными сторонами учреждения и работать на благо общества. Суть философского анализа состоит в том, чтобы обеспечить более глубокое понимание и основу для гибкого экспериментирования с будущими социальными проектами.

**Ключевые слова:** лидерство, стратегия, структура, процесс, мышление, управление проектами, социальный проект, сообщество, общество, социальное, проект, персонал.

**Abstract.** According to the author, social projects clearly define their goals and the best ways to achieve these goals, this increases the project's chances of success. The article reveals the importance of social projects. If we can distinguish between different forms of community projects and evaluate the impact of these community projects, then we will be in a better position to match projects to the strengths of the institution and to work for the greater good of the community. The essence of philosophical analysis is to provide a deeper understanding and a basis for flexible experimentation with future social projects.

**Keywords:** leadership, strategy, structure, process, thinking, project management, social project, community, society, social, project, personnel.



## Introduction

Social design is a set of theoretical and practical activities that covers all social spheres and involves the creation of specific social projects. As an academic discipline, social design is associated with the study of design methodology and technology, design tools, its system principles, forms and methods. Design is an integral part of management, which makes it possible to ensure the controllability and adjustability of a certain process. The term "design" means the process of developing a project, the implementation of which acts as a necessary result.

## Literature Review

Consequently, T. Parsons considered the process of social change caused by conscious activity of the individual, introduced the concept of “charismatic innovation” for its designation. K. Levin considered management as a process of social change. Social design and training of senior personnel is reflected in the works of many other prominent representatives of organizational theory of organizations and management practice, including P. Blau, P. Drucker, J. March, G. Simon, J. Thompson, J. Homans, etc. [1-4]

In the modern organizational tradition, innovative issues are presented in the works of I. Ansoff, K. Argiris, S. Becker, D. Millow, S. Siegel and many others. The innovation process is usually considered as a socio-cultural process associated with the change of successive phases of innovation development (innovation life cycle).

## Research Methodology

In this study, such methods and means of scientific knowledge were used as analysis and synthesis, complex and systemic analysis, comparison of conceptual theories.

## Analysis and Results

Social projects are deeply rooted in Western thought. They are based on assumptions about the nature of personality (and what it means to be completely human), the ideal of society, and the extent to which social control can exist. Changes in any of these areas will lead to changes in the nature of social projects. Social project management has evolved since early civilization as a result of many different philosophical ideas [5]. Over the centuries, many different philosophical points of view, such as Aristotelian, positivist, postmodern and many others, have tried to understand and interpret various spheres of society and advocated worthy changes.

It would be a social project aimed at changing the current situation to a more desirable one; however, the project would not be able to change the situation to such an extent that it did not reflect the next step in human evolution. Although this model is quite rare nowadays, its consequences are still relevant for modern social projects.

The value orientation of social design puts the problem of the ideal on a prominent place in his modern theories. The ideal is the highest mental expression of what is desired and due. He is constructed and clothed in a figurative form according to the dimensions of his time and most clearly expresses the trends of the era, the dominant concepts of life. The distinction of epochs in the sociocultural sense is the distinction of their inherent ideals, which can be expressed in moral patterns and fashion of

philosophical views and ideas about the social structure. Stepping onto the ground of achieving ideals, social design also acquires the features of visual evidence of its era.

Philosophical analysis offers a study of social projects and their features through the study of various ways of understanding them [6]. The nature of social projects, that is, what they essentially are, by describing the types of knowledge that researchers and practitioners possess, as well as trying to outline the main relevant features of society that lead to the choice of a particular project. To do this, the author uses several ways to separate the subject of the study in order to provide a clearer understanding of the issues involved. One way to understand social projects is to compare them with projects in the field of physical sciences.

This way of understanding social projects is useful because most people have a clear understanding of what a scientific project is, and a key feature of social projects is that people tend to want to improve the situation from what they currently consider it to be to what has been agreed as a better situation. Based on this understanding, the author assumes that the reader has some idea of what a project in the field of physical sciences is, and instead of giving lengthy explanations, he will only give significant differences between the two types of projects and assume that the reader can make comparisons on his own. Later, the author continues to talk about what is meant by the well-being of a society or an individual, and about the types of changes that people usually want to make to the current situation.

This is a necessary step, since social projects, as a rule, are attempts to improve the well-being of society or a person by stimulating any changes. But what is central to many social projects is to improve the situation in a way consistent with certain values. The analysis of the final result or the changes that the project is trying to implement leads us to study the existence of values in society and the possibility of the existence of values within society. Determining the values of society and the possibility of change is an analytical task that is solved within the framework of social and political philosophy and becomes a general theory of values and change [7]. Then it allows to divide social projects into those that are attempts to preserve value or prevent change, those that are attempts to eliminate past changes that led to a deterioration of the situation, change values or establish a new value instead of the old value.

A clear understanding of social projects is essential for subsequent arguments. Understanding how they can make the situation in a certain sector of society better, taking into account the rights, responsibilities and consequences of changes. It should be noted that social projects are aimed at changing society. The implementation of changes is aimed at improving life, changing the lifestyle according to the requirements of modern development. Development of projects for changes (or new patterns of behavior and activity) at the organizational level in accordance with the logic of the innovation model.

The term “social project” has penetrated the literature used to describe a wide range of social endeavors in which people consciously work to change some state of affairs. From improving public services to intervening in local communities and policy measures at the national level, the term is often used pejoratively to refer to some ill-conceived change efforts that have led to undesirable results. However, despite its

colloquial usage, the term “project” has a specific meaning within the framework of modern management theory and practice.

Project management is a recognized and independent area of professional practice, which involves the planned and controlled implementation of a set of measures to achieve a specific goal. A “project” is a special form of organization and coordination of work and resources. While different management disciplines will have their own approach, the generally accepted view is that it is a temporary organization to produce a unique product or service. For example, there is an information technology project to develop a new online tax return processing system, or there is a project manager for organizing a family vacation. In both cases, the project is conceived as a set of actions that differ from the usual routine in that they will not last indefinitely, there will be a certain endpoint, and as a result of these actions, some state of affairs will change [3].

There are several views on social projects. The views of Jean-Jacques Rousseau (1712-1778) on social development and the theory of social harmony subsequently had a profound impact on the concept of social projects as the basis of the future. According to Rousseau, the development from the primitive state was marked by the growing alienation experienced by the individual, which eventually led to the confusing interdependence of the mass of humanity. This should have been countered by a perfect climax; a utopian state in which human relations are characterized by the simplicity and immediacy of social ties, something that, in his opinion, was lost in the process of civilization. This perspective underlies many modern approaches to community development, which aim to “empower” communities to take independent action in their own interests. In addition, Rousseau's thesis on the “common will” suggested that it is possible to determine what is best for society, just as rational individuals can conclude what is in their own interests. Although Rousseau's ideas about how this is established and about the role of the individual in decision-making were highly authoritarian, they led to the development of consensus theory and problem-based decision-making in community and social projects.

Ferdinand Tönnies (1855-1936) was another influential philosopher whose concepts of social development influenced the definition of approaches to development. His distinction between *Gemeinschaft* and *Gesellschaft* as types of social relations. The first, representing a “community” in which social relations are characterized by concern for others, and the second, being a more utilitarian association in which individuals act in their own interests, was cited as the reason for targeted social interventions to rebuild the “community” in areas that were considered to have passed to the *Gesellschaft* type association. His belief in the potential of social engineering to solve social problems has had a direct impact on a number of social projects aimed at changing the characteristics of social policy areas. Eshelman and Jenson cite Tönnies and his theory as having had a great influence on the development of American anti-poverty policy, as they moved from actively working with individuals to focusing on building community organizations and capacity.

Organizations and other types of targeted social entities, on the one hand, were considered as systems striving for balance with a changing external environment, and, on the other hand, as fairly conservative systems whose ability to react to

environmental changes is limited, which made it possible to describe organizations as weakly plastic conservative systems.

As initial theoretical positions describing the nature of transformed social objects and mechanisms of social change, ideas about the nature of organizations developed within the framework of primarily such organization models as sociological systems were used. An active social subject- a manager who develops and offers new patterns and methods of activity, projects of the system were considered as the epicenter pushing the system to change. in a changed reality, or in order to increase competitive ability.

It is interesting to note that very few publications on community and public sector work provide a comprehensive understanding of what is meant by a social project. Due to the tendency to assume that concepts are clearly understood, too many authors leave the reader to figure out for himself what is meant by “project”. Without a clear understanding of what a social project is, it is difficult to understand what impact it has on people's quality of life, as well as what role research can play in this [4]. Lays the foundation for understanding what social projects are, so that improvement research activities can be identified and their impact assessed.

Here we are interested in a normative, not an explanatory analysis. That is, we do not seek to simply describe ways to explain various types of social projects. Our main task is to determine the conditions under which this type of social project can be successful. This is a problem of rational social activity.

## Conclusions

Thus, the dynamics of the external environment, changes in the properties of a social community or social population were considered as a factor driving social changes in these systems. The introduction of innovations often acts as a necessity, if it is recognized that without innovations it is impossible to solve the problems facing the enterprise, its implementation is inevitable.

## References:

- [1] Parsons T., “American Sociology: Prospects, problems, methods”, translated from English M., *Progress*, 1972.
- [2] Prigozhin A.I., “Innovations: incentives and obstacles (social problems of innovation)”, M., 1989.
- [3] Neuman W. L., “Basics of social research: Qualitative and quantitative approaches”, Boston, MA: Pearson, 2007, 2<sup>nd</sup> ed.
- [4] Babbie E., “The practice of social research”, Belmont, CA: Wadsworth, 2010, 12<sup>th</sup> ed.
- [5] Afanasyev S.L., “The future society. The leading socio-economic trends of our time”, –M.: Publishing House of the Bauman Moscow State Technical University, 2000, p. 567.
- [6] Bestuzhev-Lada I.V., “Predictive justification of social innovations”, – M.: *Nauka*, 1993, p. 233.
- [7] Rozin V.M., “Social design and social technologies”, *Trends and management*, No. 3, 2019, pp. 1-14.



- [8] Lyakhov I.I., “Social construction: a report at the Seventh International Sociological Congress”, – M.: *Politizdat*, 1970, pp. 87-96.
- [9] Dubrova T.A., “Statistical forecasting methods in economics: textbook, workshop, tests, program course”, Moscow State University of Economics, Statistics and Informatics, – M., 2004, p. 136.
- [10] Rapport A.G., “Designing without prototypes”, *Development and implementation of automated systems in design*, 1975, pp. 299-392.
- [11] Szonov B.V., “Sociotechnical systems as an object of permanent design and management”, – M.: *Management of the development of large-scale systems*, 2016, pp. 345-347.

## ACTUAL PROBLEMS OF NATURAL SCIENCES

---

UDC: 54,54-01,54.01/08

### SYNTHESIS OF ACETYLENIC DIOLS BASED ON THE REACTION OF TERMINAL ACETYLENIC ALCOHOLS WITH ALIPHATIC KETONES

**Otamukhamedova Guzal Qamariddinovna**

*Head of the department (PhD),*

*Chirchik State Pedagogical University*

[guzal020003@yandex.ru](mailto:guzal020003@yandex.ru)

**Ziyadullaev Odiljon Egamberdievich**

*Vice-rector, professor (PhD),*

*Chirchik State Pedagogical University*

**Buriev Forxod Khabibullaevich**

*Deputy dean of the faculty,*

*Chirchik State Pedagogical University*

**Kushbakov Farruz Zokir**

*Independent researcher,*

*Chirchik State Pedagogical University*

**Annotatsiya.** Ushbu ishda ilk bor  $\text{CaO}/\text{NH}_3/\text{Et}_2\text{O}$  katalitik sistema yordamida molekulasida alifatik, alitsiklik, aromatik va geterotsiklik o‘rinbosarlar saqlagan terminal atsetilen spirtlarining atseton, metilbutilketon va metiluchlamchibutilketonlar bilan nukleofil birikish reaksiyasi asosida yuqori biologik faollikka ega bo‘lgan atsetilen diollari sintezi o‘rganilgan. Atsetilen diollarining sintez qilish jarayoni va mahsulot unumiga turli omillar– harorat, reaksiya davomiyligi, katalizator va erituvchilar tabiati, reagent va substratlarning miqdorlari, reaksiyada hosil bo‘ladigan oraliq va qo‘shimcha mahsulotlar turlari va miqdorlari tizimli ravishda o‘rganilgan. Olingan natijalar asosida nukleofil birikish jarayonining eng muqobil sharoitlari aniqlangan hamda reaksiya mexanizmlari taklif etilgan. Sintez qilingan atsetilen diollari identifikatsiyalangan, ularning xususiy konstantalari, tuzilishi, tozaligi va tarkibi zamonaviy fizik-kimyoviy tadqiqot usullari yordamida isbotlangan.

**Kalit soʻzlar:** atsetilen diollari, alifatik ketonlar, nukleofil birikish, reaksiya mexanizmi, mahsulot unumi.

**Аннотация.** На основании влияния строения, природы и химической активности выбранных молекул ацетиленовых спиртов и кетонов на ход реакции и выход продуктов разработан относительный ряд продуктивности выходов ацетилен диолов. Систематически изучены различные факторы, влияющие на процесс синтеза и выход продуктов ацетилен диолов - температура, продолжительность реакции, природа катализаторов и растворителей, количества реагентов и субстратов, виды и количества образующихся в реакции промежуточных и побочных продуктов. На основании полученных результатов определены наиболее оптимальные условия процесса нуклеофильного сочетания и предложены механизмы реакции. Идентифицированы синтезированные ацетилендиолы, доказаны их собственные константы, структура, чистота и состав с помощью современных физико-химических методов исследования.

**Ключевые слова:** ацетилен диолы, алифатические кетоны, нуклеофильное присоединение, механизм реакции, продукт.

**Abstract.** In this work, the synthesis of highly biologically active acetylene diols was studied for the first time based on the reaction of the nucleophilic coupling of terminal acetylene alcohols with aliphatic, alicyclic, aromatic and heterocyclic substituents in their molecule with acetone, methyl butyl ketone and methyl tert-butyl ketones using the CaO/NH<sub>3</sub>/Et<sub>2</sub>O catalytic system. Based on the influence of the structure, nature and chemical activity of selected molecules of acetylene alcohols and ketones on the course of the reaction and the yield of products, a relative series of productivity yields of acetylene diols has been developed. Various factors influencing the synthesis process and the yield of acetylene diol products have been systematically studied - temperature, reaction duration, nature of catalysts and solvents, amounts of reagents and substrates, types and amounts of intermediates and by-products formed in the reaction. Based on the results obtained, the most optimal conditions for the nucleophilic coupling process were determined and reaction mechanisms were proposed. The synthesized esters have been identified, and their partial constants, structure, purity and composition have been proven using modern physicochemical methods.

**Keywords:** acetylene diols, aliphatic, ketones, nucleophilic coupling, reaction mechanism, product yield.

## Introduction

The presence of three bonds in the structure of acetylene alcohols, a hydroxyl group and mobile hydrogen, the ability of representatives of this class to enter into electrophilic and nucleophilic reactions in various processes increases their properties, they are considered an important reagent in organic synthesis. Today, acetylene alcohols are widely used as additional components in the production of vitamins, pigments, antibiotics and hormones.

## Literature Review

Acetylenic alcohols possess several reactive centers within their molecular structure, which makes them of great interest to organic chemists [1-5]. Specifically, the presence of the  $-C\equiv CH$  group in their molecules enables them to undergo various nucleophilic, electrophilic, radical, and cyclization reactions with different reagents, allowing for the formation of diverse organic compounds [6-7]. Nowadays, extensive research is being conducted on acetylenic alcohols and their derivatives in the context of their biological activity, their occurrence in natural products, their pharmacological significance, and their applicability in other scientific fields.

The development of new technologies for the synthesis of acetylenic alcohols and their derivatives is actively pursued in modern progressive countries. These studies involve systematic investigations aimed at understanding the biological activities of acetylenic alcohols, including their occurrence in aliphatic, aromatic, cyclic, and heterocyclic scaffolds, as well as the development of synthetic methodologies for their production [8-11]. R.E.Minto and his scientific team have discovered the presence of acetylenic diols as natural products in organisms such as plants, marine organisms and certain species of fungi [12]. For instance, acetylenic diols obtained from the mushroom *Clitocybe catinus* using a reagent derived from potassium carbonate and methanol exhibited significant biological activity against sarcoma [13]. The Favory reaction has been employed to synthesize second- and third-generation acetylenic diols by nucleophilic addition of acetylene to the carbonyl group, followed by oxidative coupling [14]. G.Wang and J.Dou successfully synthesized 2,4,7,9-tetramethyldecyne-5-diol-4,7, which possesses a complete dynamic surfactant behavior and can be utilized in the field of proton-absorbing black and white developer production [15]. Brazilian researchers investigated the synthesis of acetylenic diols using propargyl alcohols and aldehydes derived from aliphatic, cyclic, aromatic, and heterocyclic substrates with the assistance of  $CeCl_3/mBuLi$ . The process was carried out in tetrahydrofuran at  $-40\text{ }^\circ\text{C}$  for 4 hours, resulting in a maximum product yield [16].

## Research Methodology

In this study, as the research object in the form of a selected molecule in the  $CaO/NH_3/Et_2O$  complex catalytic system, terminal acetylenic alcohols - 1-ethynylcyclopentanol, 3-methylheptyn-1-ol-3, 2-phenylbutyn-3-ol-2 and 2-(pyridin-4)-butyn-3-ol-2 with aliphatic, alicyclic, aromatic, and heterocyclic substituents were investigated. Based on their reactions with acetone, methyl butyl ketone, and methyl ethyl ketone, the following acetylene diols were synthesized: 1-(3-hydroxy-3-methylbutyn-1-yl)cyclopentanol (1), 1-(3-hydroxy-3-methylheptyn-1-yl)cyclopentanol (2), 1-(3-hydroxy-3,4,4-trimethylpentin-1-yl)cyclopentanol (3), 2,5-dimethylnonyne-3-diol-2,5 (4), 5,8-dimethyldodecin-6-diol-5,8 (5), 2,2,3,6-tetramethyldecin-4-diol-3,6 (6), 2-methyl-5-phenylhexyn-3-diol-2,5 (7), 5-methyl-2-phenylnonyn-3-diol-2,5 (8), 5,6,6-trimethyl-2-phenylheptyn-diol-2,5 (9), 2-methyl-5-(pyridin-4-yl)hexyn-3-diol-2,5 (10), 5-methyl-2-(pyridin-4-yl)nonyn-3-diol-2,5 (11), and 5,6,6-trimethyl-2-(pyridin-4-yl)heptyn-3-diol-2,5 (12). The general scheme and

mechanism of the reaction were proposed based on literature sources and research results [17-18].

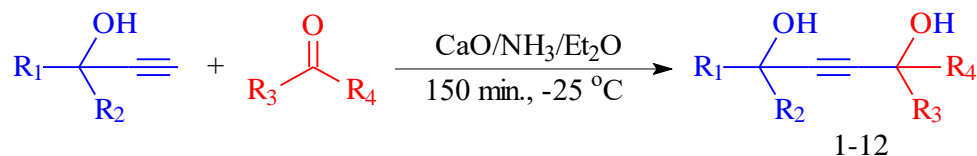

- |   |   |
|---|---|
| 1. R <sub>1</sub> R <sub>2</sub> = <i>c</i> Pt, R <sub>3</sub> = Me, R <sub>4</sub> = Me              | 7. R <sub>1</sub> = Me, R <sub>2</sub> = Ph, R <sub>3</sub> = Me, R <sub>4</sub> = Me               |
| 2. R <sub>1</sub> R <sub>2</sub> = <i>c</i> Pt, R <sub>3</sub> = Me, R <sub>4</sub> = Bu              | 8. R <sub>1</sub> = Me, R <sub>2</sub> = Ph, R <sub>3</sub> = Me, R <sub>4</sub> = Bu               |
| 3. R <sub>1</sub> R <sub>2</sub> = <i>c</i> Pt, R <sub>3</sub> = Me, R <sub>4</sub> = <sup>t</sup> Bu | 9. R <sub>1</sub> = Me, R <sub>2</sub> = Ph, R <sub>3</sub> = Me, R <sub>4</sub> = <sup>t</sup> Bu  |
| 4. R <sub>1</sub> = Me, R <sub>2</sub> = Bu, R <sub>3</sub> = Me, R <sub>4</sub> = Me                 | 10. R <sub>1</sub> = Me, R <sub>2</sub> = Py, R <sub>3</sub> = Me, R <sub>4</sub> = Me              |
| 5. R <sub>1</sub> = Me, R <sub>2</sub> = Bu, R <sub>3</sub> = Me, R <sub>4</sub> = Bu                 | 11. R <sub>1</sub> = Me, R <sub>2</sub> = Py, R <sub>3</sub> = Me, R <sub>4</sub> = Bu              |
| 6. R <sub>1</sub> = Me, R <sub>2</sub> = Bu, R <sub>3</sub> = Me, R <sub>4</sub> = <sup>t</sup> Bu    | 12. R <sub>1</sub> = Me, R <sub>2</sub> = Py, R <sub>3</sub> = Me, R <sub>4</sub> = <sup>t</sup> Bu |

### Analysis and Results

It is known that ketones, as one of the oxo compounds, possess unique reactivity. This is attributed to the distribution of electron density within the ketone molecule and the difference in relative electronegativity between carbon and oxygen atoms. The electron density of the carbonyl group in the ketone molecule is drawn towards the oxygen atom with higher electronegativity, resulting in a partial negative charge ( $\delta^-$ ) on the oxygen atom and a partial positive charge ( $\delta^+$ ) on the carbon atom, exhibiting electrophilic characteristics. This leads to the polarization of the C-C bonds adjacent to the carbonyl group in the ketone molecule, and ketones can undergo nucleophilic attacks by other molecules. Additionally, the stability of the carbon-oxygen bond in ketones is higher compared to the C=C (double bond), meaning that the energy of the C-O bond is higher than that of the two carbon-carbon bonds, in contrast, the energy of the C=C double bond is lower than the energy of two carbon-carbon bonds. The mentioned conditions facilitate the formation of complex molecules or ions with a carbonyl group, and these conditions make it easier for them to participate in various reactions.

Terminal acetylenic alcohols, in the context of the movement of hydrogen in the sp-s bond, combine with metals to form strong nucleophilic reagents, resulting in the formation of acetylene diols in a suitable manner as a result of the attack of the carbonyl group on the carbon atom in the selected ketone molecule.

Initially, ammonia interacts with the triple bond in the acetylenic alcohol molecule, increasing the mobility of the hydrogen atom in the triple bond, and as a result, the acetylenic alcohol undergoes deprotonation due to the easy replacement of the hydrogen position with a metal atom, creating favorable conditions for their combination.

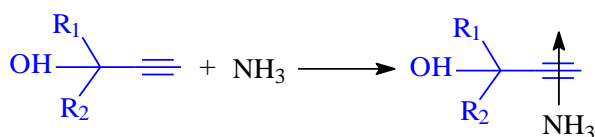



In the subsequent stage of the reaction, under the catalytic influence of the intermediate complex CaO, a strong nucleophilic reagent - acetylide is formed [21]. In this process, with the assistance of unpaired electrons of the undissociated nitrogen atom in the ammonia molecule, a proton from the catalyst, which has moved away from the solvent due to the interaction with oxygen, reacts with water molecules in the system, resulting in the formation of a hydroxide ion.

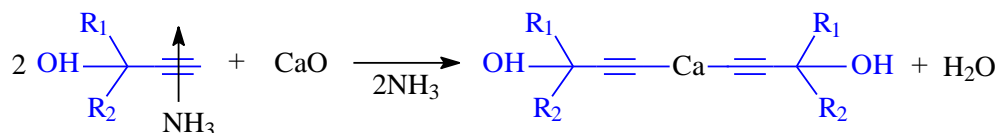

In the subsequent stage of the reaction, the calcium salt of acetylenic alcohol, which has a very high catalytic activity when reacting with 4-methylpentanone-2, is formed, resulting in the production of calcium alkoxyate of acetylene diol, which readily undergoes hydrolysis.

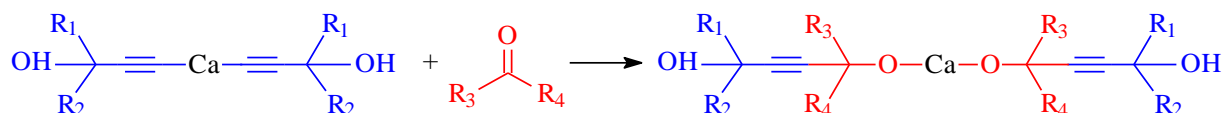

The resulting acetylene diol alkoxyate undergoes hydrolysis in an ammonia solution, producing acetylene diol and calcium hydroxide. [22-23].

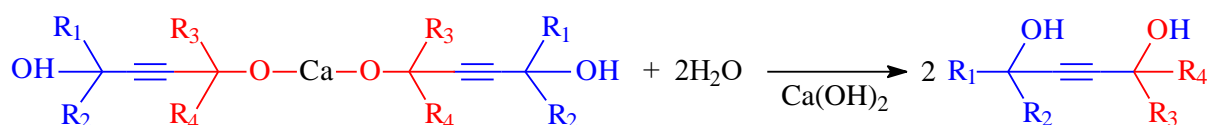

In the catalytic system of CaO/NH<sub>3</sub>/Et<sub>2</sub>O, the reactivity and phase structure of terminal acetylenic alcohols and the nature of substituents on the ketone molecules were investigated as a result of their influence on the reaction activity and phase arrangement for the purpose of obtaining the desired products. The conditions of chemical processes were systematically analyzed, including the synthesis of acetylene diols, such as temperature, reaction continuity, the nature and quantity of the solvent and catalyst, as well as the initial molar quantities of the starting materials.

As a preliminary investigation, the effect of the amount of CaO, which was chosen as the catalyst, on the selectivity of the nucleophilic addition reaction between acetylenic alcohols and ketones was studied (Figure 1). The molar quantities of CaO were varied from 0,01 to 0,1 in this case.

As observed from the figure, when CaO was taken in the amount of 0,025 moles, it exhibited maximum catalytic activity. Consequently, a selective environment was created for the deprotonation of terminal acetylenic alcohols and their subsequent addition reaction with the oxygen of the carbonyl group in hydrogen ketone molecules. By mutually influencing the reagent and substrate, a new sp-sp<sup>3</sup> bond was formed, leading to the synthesis of acetylene diols with maximum yield (1- 78,2%, 2- 75,4%, 3- 71,3%, 4- 76,3%, 5- 68,8%, 6- 62,0%, 7- 85,3%, 8- 82,0%, 9- 79,8%, 10- 70,1%, 11- 63,4%, 12- 58,2%).

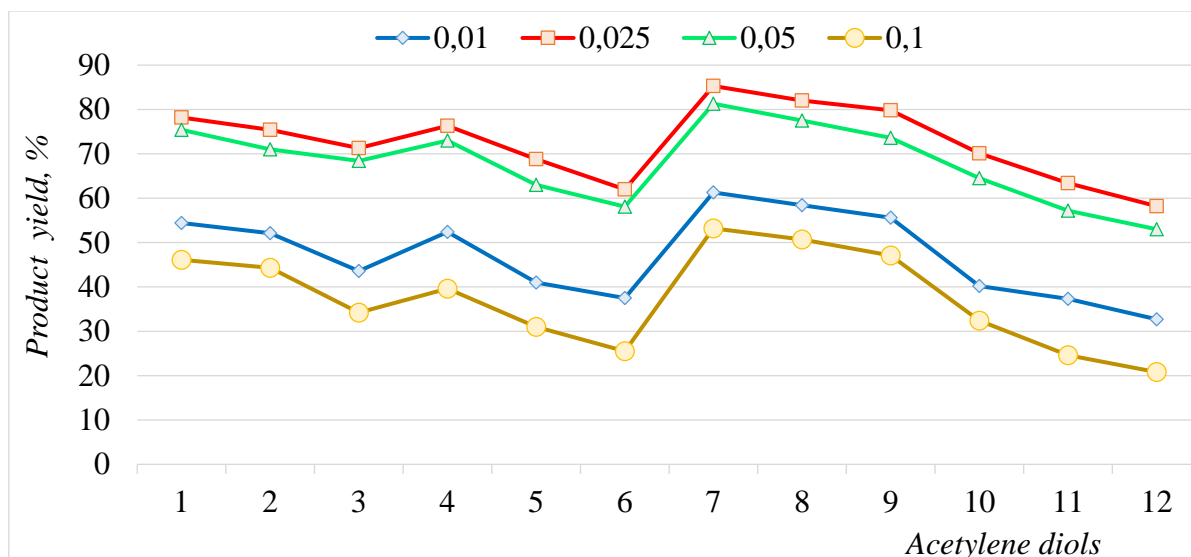

**Figure 1.** The effect of the amount of CaO on the yield of acetylene diols (temperature:  $-25\text{ }^{\circ}\text{C}$ , solvent: diethyl ether, reaction duration: 150 minutes).

However, when the catalyst amount was increased to 0,05 or 0,1 moles, additional reactions occurred during the process. These included the production of calcium alkoxylates by the interaction of the synthesized acetylene diols with other catalysts, as well as the occurrence of vinyl oxy ethers, short-term dehydration, internal molecular cyclization, transformation, dimerization, condensation, and enolization reactions in the presence of phenylacetylene in the system. These additional and intermediate compounds resulted in a significant decrease in the yield of acetylene diols due to their consumption.

In order to investigate the reaction continuity and determine the corresponding conditions for the process, the reactions were carried out in intervals ranging from 90 minutes to 180 minutes. The results are presented in Table 1.

**Table 1.** Effect of reaction duration on the yield of acetylene diols (temperature  $-25\text{ }^{\circ}\text{C}$ , solvent: diethyl ether, CaO amount: 0,025 moles).

| Acetylene diols | Product yield, % |             |             |             |
|-----------------|------------------|-------------|-------------|-------------|
|                 | 90 minutes       | 120 minutes | 150 minutes | 180 minutes |
| 1               | 43,5             | 62,3        | 78,2        | 67,1        |
| 2               | 39,2             | 58,5        | 75,4        | 64,2        |
| 3               | 36,0             | 55,2        | 71,3        | 60,8        |
| 4               | 42,3             | 59,7        | 76,3        | 65,0        |
| 5               | 34,1             | 52,5        | 68,8        | 57,5        |
| 6               | 28,4             | 46,1        | 62,0        | 51,4        |
| 7               | 51,3             | 69,3        | 85,3        | 74,2        |
| 8               | 48,1             | 66,1        | 82,0        | 74,1        |
| 9               | 45,0             | 63,4        | 79,8        | 69,5        |
| 10              | 35,9             | 54,6        | 70,1        | 59,4        |
| 11              | 29,7             | 47,0        | 63,4        | 52,2        |
| 12              | 23,0             | 41,5        | 58,2        | 46,9        |

When the nucleophilic addition reaction was carried out for 90 and 120 minutes, it was determined that the catalyst did not exhibit complete catalytic activity, and the formation of intermediate calcium acetylide was insufficient. As a result, the initial reagents did not fully engage in the desired reaction and underwent partial condensation, as well as partial enolization of the ketones, leading to the formation of intermediate and additional compounds. When the reaction was conducted for a duration of 150 minutes, the selectivity of the catalyst was fully manifested. The formation of an active complex in the system, along with a decrease in the activation energy and an increase in the reaction rate, resulted in the highest yield of the desired product. However, when the reaction duration was extended to 180 minutes, the mutual interaction or influence of the initial and resulting substances in the reactor, the additional effect of the catalyst, various coordinating complex components on the coordination sphere, and the twisting of sterically hindering groups for the formation of C-C bond in the reagent and substrate, resulting in the formation of additional products due to the decrease in the quantity of the desired product were observed in the reaction mixture.

The above experiment was conducted in the temperature range of 25 °C to -40 °C for the purpose of synthesizing acetylene diols, and the results of the specific analysis were evaluated (Figure 2).

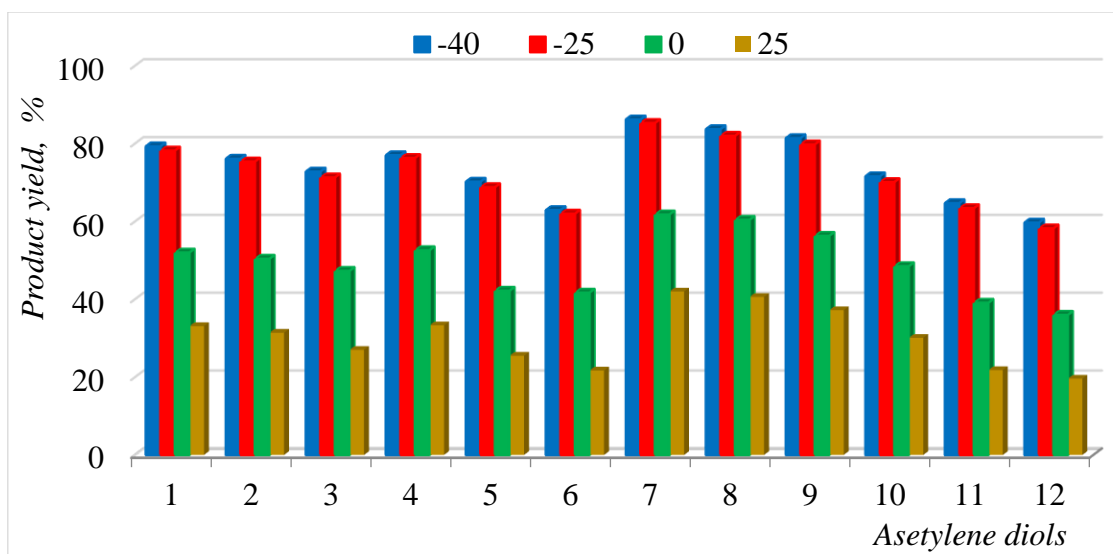

**Figure 2.** Effect of temperature on the yield of acetylene diols (reaction duration: 150 minutes, solvent: diethyl ether)

Based on the comparative analysis, it was determined that acetylene diols exhibited maximum yield at -25 °C temperature. In this process, the energy of colliding particles was equivalent to the activation energy, leading to the formation of new  $sp^3-sp^3$  bonds in acetylene alcohols and ketone molecules. In other words, at -25 °C temperature, due to the substantial energy possessed by the colliding molecules and ions, the nucleophilic reagents (calcium acetylide) resulted in the efficient production of the desired product yield.

However, an increase in temperature resulted in a sharp decrease in the yield of the product. In this case, it was observed that the decrease in temperature affected both the

product yield and the direction of the reaction. Specifically, the polymerization of acetylene diols, the formation of resinous compounds, as well as the production of vinyl ethers from terminal acetylene alcohols that did not participate in the reaction, led to a decrease in product yield (1- from 78,2 to 52,0%; 2- from 75,4 to 50,4%; 3- from 71,3 to 47,3%; 4- from 76,3 to 52,6%; 5- from 68,8 to 42,2%; 6- from 62,0 to 41,7%; 7- from 85,3 to 61,8%; 8- from 82,0 to 60,4%; 9- from 79,8 to 56,3%; 10- from 70,1 to 48,5%; 11- from 63,4 to 39,1%; 12- from 58,2 to 36,0%).

Based on the obtained results, the most favorable conditions for the synthesis of acetylene diols were determined using the  $\text{CaO}/\text{NH}_3/\text{Et}_2\text{O}$  complex catalytic system. According to the findings, the optimal conditions were as follows: temperature of  $-25^\circ\text{C}$ , reaction duration of 150 minutes, initial total amount of  $\text{CaO}$  relative to the mass of starting materials at 0,025 moles, and when the starting materials were taken in an equimolar ratio, acetylene diols were synthesized with the highest yield.

The purity, composition, structure, and specific characteristics of the synthesized acetylene diols were analyzed using modern analytical techniques such as IR spectroscopy,  $^1\text{H-NMR}$ ,  $^{13}\text{C-NMR}$  spectroscopy, mass spectrometry, chromatography (GC, HPLC), quantum chemical calculations, biological, and other physicochemical research methods. Specific constants were determined, and energetic and quantum chemical properties were evaluated. The charges of atoms in the molecule, electron densities, and optical properties were investigated using specialized software tools (Table 2).

**Table 2.** Acetylene diols quantum chemical results.

| Acetylene diols | Formation enthalpy, kcal/mol | Van der Waals energy, kcal/mol | Coulomb energy, kcal/mol | Torsional energy, kcal/mol | Valence bond energy, kcal/mol | Bond energy, kcal/mol |
|-----------------|------------------------------|--------------------------------|--------------------------|----------------------------|-------------------------------|-----------------------|
| 1               | 16,0326                      | 4,0885                         | 0,5031                   | 7,6384                     | 0,5627                        | 3,2398                |
| 2               | 23,6094                      | 5,2953                         | 2,9360                   | 10,1677                    | 0,9742                        | 4,2362                |
| 3               | 21,2484                      | 5,8970                         | 0,4581                   | 8,7364                     | 1,5790                        | 4,5779                |
| 4               | 12,7729                      | 4,2460                         | 1,2041                   | 3,8602                     | 0,8872                        | 2,5753                |
| 5               | 11,0322                      | 4,5630                         | 0,4471                   | 1,9544                     | 1,2021                        | 2,8657                |
| 6               | 14,2038                      | 5,6473                         | 1,0300                   | 2,9177                     | 1,8276                        | 2,7812                |
| 7               | 2,5550                       | 2,4704                         | 2,0684                   | -4,6475                    | 0,6146                        | 2,0492                |
| 8               | 5,9941                       | 3,9447                         | 2,1165                   | -3,8599                    | 0,9920                        | 2,8009                |
| 9               | 5,6177                       | 4,1200                         | 0,9851                   | -4,2627                    | 1,6282                        | 3,1475                |
| 10              | 9,8741                       | 5,2352                         | 1,0801                   | 1,1113                     | 0,6728                        | 1,7746                |
| 11              | 11,6829                      | 6,4232                         | 0,7694                   | 1,0864                     | 0,9928                        | 2,3946                |
| 12              | 10,2917                      | 6,8311                         | 0,8813                   | 2,1034                     | 1,6896                        | 2,9275                |

Based on the analysis results, the nature of radicals in terminal acetylenic alcohols and ketones, as well as their phase-specific reactivity, was determined in terms of their nucleophilic aggregation process (reactivity). According to this, the order of product yield was established as follows:  $12 < 6 < 11 < 5 < 10 < 3 < 2 < 4 < 1 < 9 < 8 < 7$ .

## Conclusions

For the first time, a method for synthesizing aliphatic acetylenic diols was established based on the reaction of acetylenic alcohols with ketones using the CaO/NH<sub>3</sub>/Et<sub>2</sub>O complex catalytic system, and an experimental setup was developed.

The synthesis of acetylenic diols, including the reaction method, mechanism, reaction conditions, and kinetics, was investigated. The specific characteristics of the synthesized acetylenic diols, including purity, composition, and structure, were determined using modern physicochemical research methods.

The influence of the catalytic system used in the synthesis of acetylenic diols on the product yield and the progress of the reaction was studied, focusing on the selectivity, reactivity, and stability of calcium oxide and ammonia.

## References:

- [1] Tsuji H., Kawatsura M., "Transition-Metal-Catalyzed Propargylic Substitution of Propargylic Alcohol Derivatives Bearing an Internal Alkyne Group", *Asian Journal of Organic Chemistry*, Volume 9, Issue 12, 2020, pp. 1924-1941.
- [2] Noelia Velasco, Anisley Suárez, Fernando Martínez-Lara, Manuel Angel Fernández-Rodríguez, Roberto Sanz and Samuel Suárez-Pantiga, "From Propargylic Alcohols to Substituted Thiochromones: gem Disubstituent Effect in Intramolecular Alkyne Iodo/hydroarylation", *Journal of Organic Chemistry*, Volume 86, 2021, pp. 7078-7091.
- [3] Hongwei Qian, Dayun Huang, Yicheng Bi, Guobing Yan, "2-Propargyl Alcohols in Organic Synthesis", *Advanced Synthesis and Catalysis*, Volume 361, Issue 14, 2019, pp. 3240-3280.
- [4] Roy R., Saha S., "Scope and advances in the catalytic propargylic substitution reaction", *RSC Advances*, Volume 8, Issue 54, 2018, pp. 31129-31193.
- [5] Voronin V.V., Ledovskaya M.S., Bogachenkov A.S., Rodygin K.S., Ananikov V.P. "Acetylene in organic synthesis: Recent progress and new uses", *Molecules*, Volume 23, 2018, p. 2442.
- [6] Xiaoxiang Zhang, Wan Teng Teo, Sally, Philip Wai Hong Chan, "Bronsted Acid Catalyzed Cyclization of Propargylic Alcohols with Thioamides. Facile Synthesis of Di- and Trisubstituted Thiazoles", *Journal of Organic chemistry*, Volume 75, Issue 18, 2010, pp. 6290-6293.
- [7] Kaluvu Balaraman, Venkitasamy Kesavan, "Efficient Copper (II) Acetate Catalyzed Homo- and Heterocoupling of Terminal Alkynes at Ambient Conditions", *Synthesis*, No. 20, 2010, pp. 3461-3466.
- [8] Jefferson Luiz Princival, Jeily Gomes Ferreira, "CeCl<sub>3</sub>-mediated addition of acetylenic bis-lithium salts to aldehydes and ketones: An efficient route to bis-substituted alkyne diols", *Tetrahedron Letters*, Volume 58, Issue 36, 2017, pp. 3525-3528.
- [9] Neeraj Gupta, Shallu, Goverdhan Lal Kad and Jasvinder Singh, "First total synthesis of acetylenic alcohol 15-methyltriosa-2,4-diyne-1, 6-diol



- (strongylodiol-G) derived from marine sponge”, *Natural Product Research*, Volume 28, No. 7, 2014, pp.424-430.
- [10] Fushan Chen, Ying Xia, Rongcan Lin, Yuxing Gao, Pengxiang Xu, Yufen Zhao, “Copper-Catalyzed Direct Twofold C–P Cross-Coupling of Unprotected Propargylic 1,4-Diols: Access to 2,3-Bis(diarylphosphanyl)-1,3-butadienes”, *Organic Letters*, No. 21, 2019, pp. 579-583.
- [11] Voituriez A., Pérez-Luna A., Ferreira F., Botuha C., and Chemla F., “Stereo- and Enantioselective Synthesis of Acetylenic 2-Amino-1,3-diol Stereotriads”, *Organic Letters*, Volume 11, Issue 4, 2008, pp. 931-934.
- [12] Robert E. Minto, Brenda J. Blacklock, “Biosynthesis and function of polyacetylenes and allied natural products”, *Progress in Lipid Research*, Volume 47, Issue 4, 2008, pp. 233-306.
- [13] Iza Mirela R.G. Princival, Jeily G. Ferreira, Teresinha G. Silva, Jaciana S. Aguiar, Jefferson L. Princival, “Synthesis and in vitro evaluation of (*R*), (*S*) and (*R/S*)-2-hexyne-1,4-diol, a natural product produced by fungus *Clitocybe catinus*, and related analogs as potential anticancer agents”, *Bioorganic and Medicinal Chemistry Letters*, Volume 26, Issue 12, 2016, pp. 2839-2842.
- [14] Zokirov S., “Research of the Processes of Synthesis of Acetylene Diols and Study of their Anti-Corrosive Properties”, *Natural Volatiles and Essential Oils*, №8(5), 2021, pp. 10745-10750.
- [15] Guoyong Wang, Jiangxun Dou, Jiaoyan Liu, Yan Wang, Lifei Zhi, Yuanyang Wang, Zhi Yun Li., “Influence of acetylene bond on surface activity of acetylenic diols in aqueous solutions”, *Colloid and Interface Science Communications*, Volume 54, 2023, p.100710.
- [16] Jefferson Luiz Princival, Jeily Gomes Ferreira, “CeCl<sub>3</sub>-mediated addition of acetylenic bis-lithium salts to aldehydes and ketones: An efficient route to bis-substituted alkyne diols”, *Tetrahedron Letters*, Volume 58, 2017, pp. 3525-3528.
- [17] Noriki Kutsumura, Mai Inagaki, Akito Kiriseko, Takao Saito, “Novel One-Pot Synthetic Method for Propargyl Alcohol Derivatives from Allyl Alcohol Derivatives”, *Synthesis*, Volume 47, Issue 13, 2015, pp. 1844-1850.
- [18] Sarvinoz Tirkasheva, Odiljon Ziyadullaev, Abduvahob Ikramov, Forxod Buriev, “1-Etinilsiklogeksanolning ayrim ketonlar bilan tetrabutylammoniy gidroksid yordamida enantiosektiv alkinillanish asosida atsetilen diollar sintezi”, *Kimyo va kimyo texnologiyasi*, № 3, 2022, pp. 46-54.
- [19] Kobichev V.B. “Osnovi teorii grup i yee ximicheskie prilozhenii”, - Kazan: *Aspirant*, 2014, p. 108.
- [20] Ziyadullaev O.E., Ikramov A.I., Turabdjanov S.M. “Nauchnie osnovi sinteza aromaticeskix asetilenovix spirtov po metodu Favorskogo i Grinyara-Iotsicha”, *Nauchniy jurnal Mir nefteproduktov (Rossiya)*, №5, 2016, p. 23-25.
- [21] Benjamin M. Partridge, Latitia Chausset-Boissarie, Matthew Burns, Alexander P. Pulis, Varinder K. Aggarwa, “Enantioselective Synthesis and Cross-Coupling of Tertiary Propargylic Boronic Esters Using Lithiation-



Borylation of Propargylic Carbamates”, *Angewandte Chemie International Edition*, Volume 51, 2012, pp. 11795-11799.

- [22] Fiona Kirby, Anne-Eva Nieuwelink, Bonny Kuipers, Anton Kaiser, Pieter Bruijninx, Bert Weckhuysen “CaO as Drop-In Colloidal Catalysts for the Synthesis of Higher Polyglycerols”, *Chemical European Journal*, Volume 21, 2015, pp. 5101-5109.
- [23] San’at Samatov, Abduvaxab Ikramov, Saida Abdurahmanova, Odiljon Ziyadullayev, Guzal Otamuhamedova, “Benzaldegid va uning galogenli xosilalari asosida aromatik atsetilen spirtlari sintezi”, *Kimyo va kimyoviy texnologiya jurnali*, №1, 2022, p. 42-48.

UDC: 54,544.02,549.2

## STUDY OF THE STRUCTURE OF THE NITRIDED LAYER FOR THE STRENGTH OF THE ADHESIVE BOND OF WEAR-RESISTANT COATING IN R9M4 STEEL

**Isayev Doniyor Toshbotirovich**  
*PhD in Department Mechanical Engineering at Navoi state mining and technological university*  
[doniyor\\_isayev@mail.ru](mailto:doniyor_isayev@mail.ru)

**Ataullayev Azizjon Odilovich**  
*PhD in Department Mechanical Engineering at Navoi state mining and technological university*  
[Aziz-217@mail.ru](mailto:Aziz-217@mail.ru)

**Jurayev Nodirbek Normurodovich**  
*PhD in Department Mechanical Engineering at Navoi state mining and technological university*  
[doniyor\\_isayev@mail.ru](mailto:doniyor_isayev@mail.ru)

**Obloqulov Jahongir Shavkat Ugli**  
*student at Navoi state mining and technological university*  
[obloqulovjahongir423@gmail.com](mailto:obloqulovjahongir423@gmail.com)

**Annatsiya:** Tadqiqot TiAlN qoplamani mustahkam adgezion aloqasi bilan tezkesar po‘lat asosida azotlashtirilgan qatlamini baholash ta'siriga yo'naltirilgan. Ikki bosqichli vakuum kanalida ionli azotlash va gaz plazmasi usulida azot tarkibini va gaz aralashmasini argon bilan o'zgartirib, strukturaviy qatlamni boshqarishga imkon beradi. Tadqiqotlar shuni ko'rsatdiki, azotlangan qatlamning tuzilishi qoplamaning mustahkamligi kuchiga sezilarli ta'sir qiladi. Past azot

miqdorida azotli gazli muhitda hosil bo'lgan azotlangan qatlam yopishqoqlik birikmaning mustahkamligini oshirishi va asbobning sozlash xususiyatlarini yaxshilashi eksperimental tarzda aniqlangan.

**Kalit so'zlar:** Ion azotlash, gaz plazmasi, azotlangan qatlamning tuzilishi, yopishtiruvchi bog'lanish mustahkamligi, TiAlN qoplamasi, tezkesar po'lat, optimal azotlash parametrlari.

**Аннотация.** Целью исследования является оценка влияния структуры азотированного слоя на прочность адгезионной связи покрытия TiAlN с основой из быстрорежущей стали. Метод ионного азотирования в газовой плазме двухступенчатого вакуумно-дугового разряда позволяет управлять структурой слоя путем изменения содержания азота в газовой смеси с аргоном. Исследования показали, что структура азотированного слоя существенно влияет на прочность адгезионного соединения покрытия. Экспериментально установлено, что азотированный слой, формируемый в газовой среде с низким содержанием азота, обеспечивает повышение прочности клеевого соединения и улучшение режущих свойств инструмента.

**Ключевые слова:** ионное азотирование, газовая плазма, структура азотированного слоя, прочность адгезионного соединения, покрытие (Ti, Al)N, быстрорежущая сталь, оптимальные параметры азотирования.

**Abstract.** The study is aimed at assessing the effect of the structure of the nitrated layer on the adhesive bond strength of the coating TiAlN with a high-speed steel base. The method of ion nitriding in a gas plasma of a two-stage vacuum arc discharge allows you to control the structure of the layer by changing the nitrogen content in a gas mixture with argon. Studies have shown that the structure of the nitrated layer significantly affects the adhesive bond strength of the coating. It has been experimentally established that the nitrated layer formed in a gas medium with a low nitrogen content provides increased adhesive bond strength and improved cutting properties of the tool.

**Keywords:** Ionic nitriding, gas plasma, structure of the nitrated layer, adhesive bond strength, coating (Ti, Al)N, high-speed steel, optimal nitriding parameters.

## Introduction

Despite the high wear resistance of cutting tools made of high-speed steels, they are still susceptible to wear and breakage. At the same time, breakdowns, chipping and discoloration of the cutting wedge account for up to 80% of failures. High-speed steels are manufactured both in the classical way (casting steel into ingots, rolling and forging) and by powder metallurgy methods (spraying a jet of liquid steel with nitrogen). The quality of high-speed steel is largely determined by the degree of its forging. With insufficient forging of steel made in the classical way, carbide liquation is observed. In the manufacture of high-speed steels, a common mistake is to approach it as "self-hardening steel". That is, it is enough to heat the steel and cool it in the air, and you can get a hard, wear-resistant material [1]. This approach does not take into



account the features of high-alloy tool steels at all. High-speed steels must be annealed before quenching. In poorly annealed steels, a special type of marriage is observed: naphthalene fracture, when at normal hardness the steel has increased brittleness. A competent choice of quenching temperature ensures maximum solubility of alloying additives in  $\alpha$ -iron, but does not lead to grain growth.

### Research Methodology

During ionic nitriding in a gas plasma of a two-stage vacuum arc discharge, the structure of the formed layer can be controlled by changing the nitrogen content in the gas mixture with argon. It was investigated that during combined processing, the structure of the layer obtained by ion nitriding has a significant effect on the adhesive bond strength of the coating TiAlN with a high-speed substrate [2]. As is known, the high adhesive bond strength of the coating with the tool matrix is the most important condition for the successful operation of a coated tool.

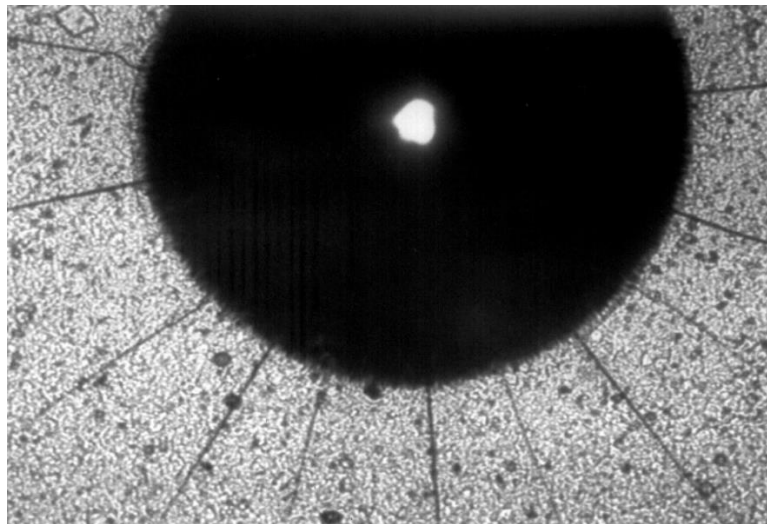
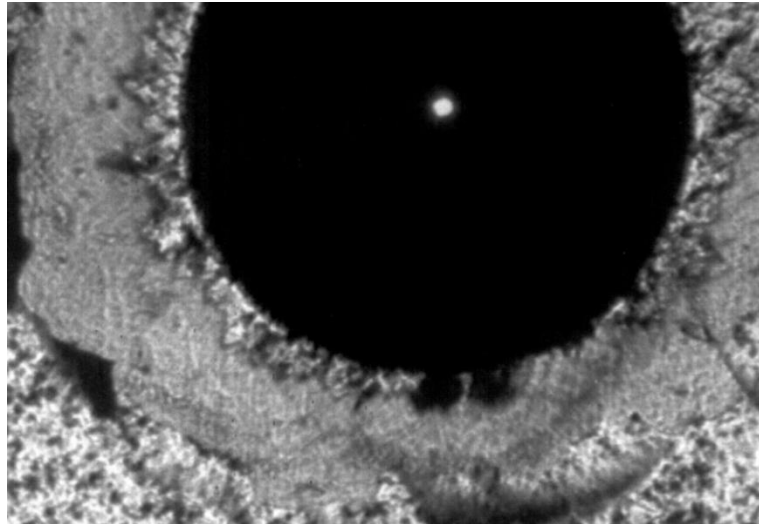

**Figure 1.** Indenter imprint on a sample made of steel P9M4.

The adhesive bond strength of the coating with the substrate was determined by the method of indentation of a diamond indenter on a Rockwell device with a load of 1.47 kN. The measurements were of an estimated, qualitative nature, therefore, differences in the phase composition and microhardness of the substrates, in this case nitrided according to different modes of high-speed steel, were not taken into account [3,4].

### Analysis and Results

Figure 1 shows a photograph illustrating the dependence of the adhesive bond strength of the coating (Ti<sub>0.7</sub>Al<sub>0.3</sub>)N on the structure of the nitrided layer. When a diamond indenter is inserted into a sample with a structure that is formed during nitriding in a 100% medium, peeling of the coating is not observed, but a large number of cracks are visible on the coating surface, spread radially from the place of application of the load. For comparison, Figure 2 shows a photograph of the injection zone with an indenter of an unionized coated sample (Ti<sub>0.7</sub>Al<sub>0.3</sub>)N. In this case, a completely opposite picture is observed—due to the sharp difference in the hardness of the coating and the substrate, when exposed to a load, the coating collapses and flakes off.



**Figure 2.** Indenter imprint on a sample made of steel P9M4.

A study of the cutting properties of a tool with a wear-resistant complex consisting of a nitrided layer and a coating ( $\text{Ti}_{0.7}\text{Al}_{0.3}\text{N}$ ) showed that the nitrided layer formed in an atmosphere of pure nitrogen does not provide high cutting properties of a high-speed tool during operation [5-8]. This mainly applies to the operation of the tool during milling operations, when already in the first minutes of operation of the tool, brittle destruction of its cutting edges was observed (Fig.3).

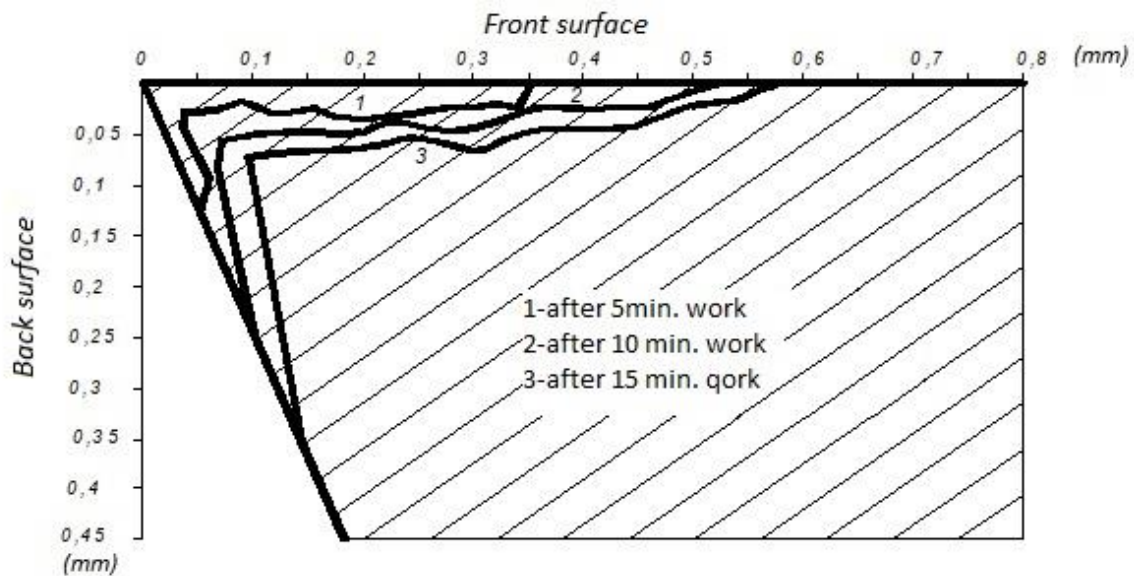

**Figure 3.** The nature of the destruction of the cutting edges of the P9M4 steel tool after combined processing.

The loss of cutting properties of the surface layer of high-speed steel P8p During intermittent cutting is due to brittle fracture as a result of cracking due to variable heat-and-power loads arising from alternating working and idle strokes, as well as adhesive fatigue failure during separation of the “stagnant zone” - the chip area in the plastic deformation area [4]. This is explained by the formation on the surface of the nitrided layer of high-speed steel under a coating ( $\text{Ti}_{0.7}\text{Al}_{0.3}\text{N}$ ) of an N nitride zone based on a highly nitrogenous ( $\gamma$ -phase, which has increased hardness and brittleness and greatly reduces the plasticity of the nitrided layer [9-11].

Studies of the adhesive bond strength of the coating (Ti<sub>0.7</sub>Al<sub>0.3</sub>)N with P9M4 steel samples nitrided in various nitrogen-argon gas mixtures have shown the following. With a nitrogen content of less than 70% in the gas mixture with argon, a sharp improvement in the adhesive bond strength of the coating with a high-speed substrate is observed. It can be seen that there is no peeling of the coating on the samples, nor obvious cracks, which were found on samples nitrided at 100% N<sub>2</sub>.

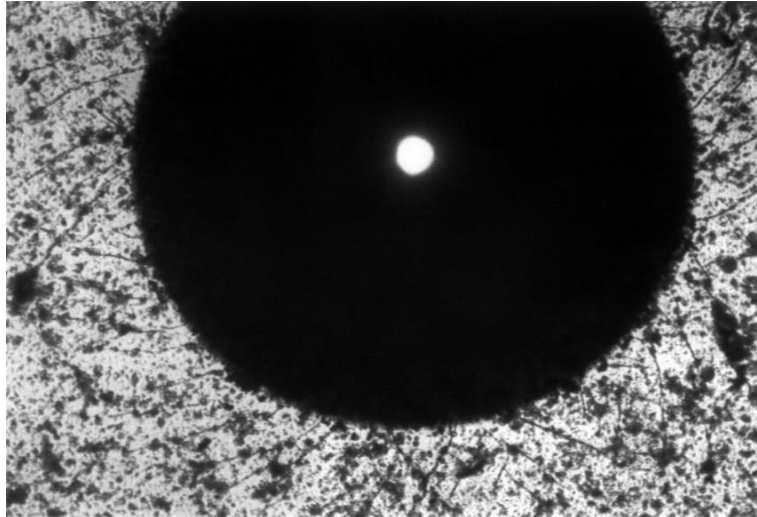

**Figure 4.** Indenter imprint on a sample made of steel P9M4.

When studying the cutting properties of these samples, no brittle destruction of the cutting edges was revealed, manifested in the form of discoloration (Fig. 6).

During intermittent cutting, the maximum cutting ability was shown by coated samples that were pre-tested in a medium containing 30% N<sub>2</sub>-70% Ar.

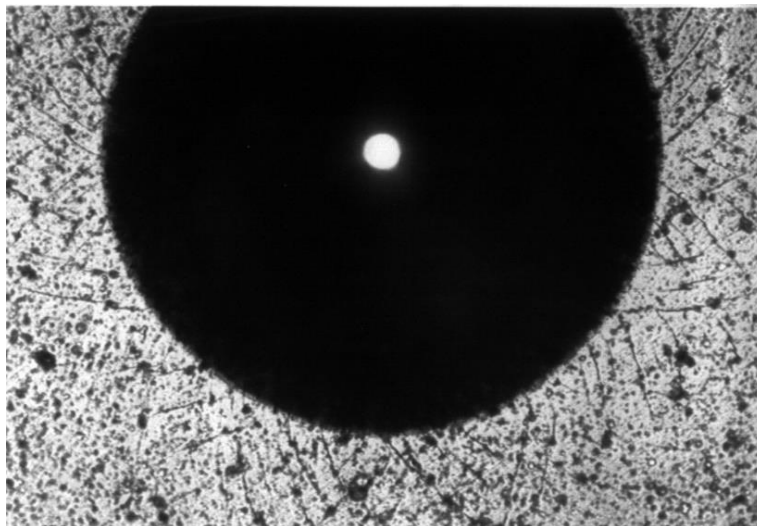
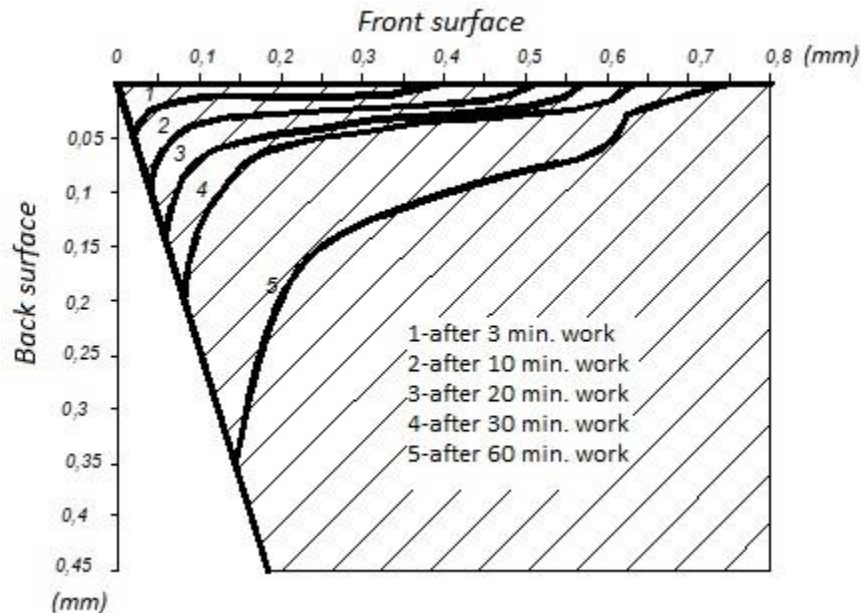

**Figure 5.** Indenter imprint on a sample made of steel P9M4.

Metallographic studies have shown that the structure of the surface layer of high-speed steel nitrided in a gaseous medium containing 30% N<sub>2</sub>-70% Ar is a solid solution of nitrogen and carbon in  $\alpha$ -iron, in which there is a small amount of dispersed nitrides of alloying components [5]. Such a nitrided layer is resistant to variable loads and

provides high adhesive bond strength of the coating with the substrate and increased resistance to loads arising during intermittent cutting.

In the case of operation of a high-speed tool under continuous loads (during turning), the maximum cutting capacity was shown by coated samples that were pre-nitrided in a gas medium containing 60%N<sub>2</sub>-40%Ar.



**Figure 6.** The nature of the destruction of the cutting edges of the P9M4 steel tool after combined processing.

Metallographic and X-ray diffraction studies have shown that in this case, nitrogenous martensite is present in the structure of the nitrided layer, in which excess nitrides of the Fe<sub>3</sub>(W, Mo)<sub>3</sub>(C, N) type and a significant number of special nitrides of alloying elements (W, Mo, Cr, V) are observed. This structure provides high adhesive bond strength base coatings, higher plastic deformation resistance and heat resistance.

## Conclusions

1. The structure of the nitrided layer has a very great influence on the adhesive bond strength of the coating with the high-speed matrix and the cutting properties of the tool.
2. Knowing the nature of the loads acting on the tool during the cutting process, due to the introduction of inert argon gas into the nitrogen-containing atmosphere, it is possible to control the phase composition of the formed layer and obtain the required structure.
3. A nitrided layer based on nitrogen-enriched martensite without the formation of an external nitride zone, which is optimal for tool operation under shock-cyclic loads, can be obtained by nitriding in an environment containing 30% N<sub>2</sub> and 70% Ar, and a structure that is optimal for continuous cutting at 60%.

### References:

- [1] Akhmedov K. I., Isaev D. T., Ashurov K. K., and Salimjonov K., “Influence of integrated machining on the cutting capacity of fast-cutting steel R6M5”, *ISJ Theoretical & Applied Science*, 09 (89), 2020, pp. 322-327.
- [2] Kizi I. M. S., Vladirovna A. E., and Toshbotirovich I. D., “Specific features of the effect of electronic beams on hard alloy”, In *Archive of Conferences*, Vol. 25, No. 1, May, 2021, pp. 202-204.
- [3] Doniyor T. I., “Ion nitriding and surface alloying of H13A hard alloy cutting tools”, *Materials Protection*, 64(2), 2023, pp.161-169.
- [4] Fedorov S. V., Akhmedov H. I., Isaev D. T., and Saibov M. R. F., “Synthesis of refractory phases during surface micro-alloying with the use of a wide-aperture electron beam”, *Strategiya sovremennogo nauchno-tekhnologicheskogo razvitiya rossii: problemy i perspektivy realizatsii*, 2021, pp. 32-35.
- [5] Fedorov S.V., Islomovich, A., Isaev D.T., Yakhshiev Sh.N., and Ashurov H. Sh., “The formation of the geometry of the edge of the cutting tool by laser ablation and the effect of laser treatment on the durability of plates made of P6M5”. *Ilm-fan va innovation rivojlanish/Science and innovative development*, 3(5), 2020, pp. 80-85.
- [6] Isaev D.T., and Urazmanova Z. R., “The method of complex processing of carbide plates made of H13A alloy”. In *Science, Society, Technology: problems and prospects of interaction in the modern world*, 2022, pp. 23-27.
- [7] Isaev D.T., “Study of the properties of the h13a carbide plate (analogue vk6om) after comprehensive processing in cutting steel 18xgt”. *Theoretical and applied science Founders: Theoretical and Applied Science*, (12), 2021, pp. 1232-1238.
- [8] Isaev D.T., Ashurov K. K., Urinova I.F., and Istamova M.S., “Integrated surface vacuum-plasma hardening of tools from high-alloyed quick-steel steel”. *International Journal of Engineering and Information Systems (IJEAIS)*, 2020, pp. 98-99.
- [9] Smirnov V.P., Alekseev D.A., and Pavlov K.I., “Effects of coating composition on tool wear during high-speed machining: experimental and numerical analysis”. *Wear and tear*, 376-377(5), 2017, pp. 890-905.
- [10] Ivanov P.P., Smirnov A.A., and Kozlov V.V., “Modern coatings for cutting tools: an overview”. *Journal of Materials Processing Technology*, 45(2), 2022, pp. 210-225.
- [11] Grigoriev V.D., Ivanova E.N., and Petrova O.S., “Development of wear-resistant coatings for cutting tools: a complete overview”. *Surface and Coating Technology*, 265(1), 2018, pp. 110-125.

## ACTUAL PROBLEMS OF MATHEMATICS, PHYSICS AND MECHANICS

---

UDC: 51,517,517.9,616.1

### MATHEMATICAL, ALGORITHMIC AND SOFTWARE OF THE SYSTEM FOR RECORDING AND DIAGNOSTIC OF ELECTROCARDIOGRAPHIC SIGNALS

**Rakhimova Feroza Baxtiyarovna**

*Researcher in Tashkent university  
of information technologies*

[ferozarahimova25@gmail.com](mailto:ferozarahimova25@gmail.com)

**Annotatsiya.** Jahon sog'liqni saqlash tashkilotidan kardio infark o'limini oldini olishning samarali usullaridan biri zamonaviy elektrokardiografik (EKG) signallarini raqamli qayta ishlash algoritmlariga asoslangan o'z vaqtida tashxis qo'yishdir. Bugungi kunda yurak-qon tomir kasalliklarini tashxislashni samaradorligini oshirish uchun elektrokardiografik signallarni avtomatik aniqlashning bir qator usullari ishlab chiqilgan. Kompyuter texnologiyalari va matematik modellardan foydalanib, qayd etilgan signaldagi turli xil tibbiy hodisalarning asosiy parametrlarini qayd etish, tanib olish va hisoblash hamda xulosa chiqarishda ularda maslahatchi quyi tizimlarni amalga oshirishga urinishlargacha bo'lgan funksiyalarni bajaradigan turli xil tibbiy tizimlarni yaratish, shuningdek, salomatlik holati haqida tashxislash xulosalarni rivojlantirishga olib keladi. Tadqiqotda EKG signallarini qayd qilish jarayonini, sonli yechishda ajratish va vaqt bo'yicha oshkormas sxemasi asosida amalga oshirish, algoritmik va dasturiy ta'minoti ishlab chiqish bo'yicha fikr yuritiladi. Ma'lumot olish jarayoni ma'lum mezonlar bo'yicha ko'rsatilgan "axborotli" xususiyatlarini tanlash va ularni tasniflash egri chiziq sifatida taqdim etish tavsifi orqali tanlangan bo'limlarni sinflash amalga oshirilgan. Mazkur maqolada EKG signalini filtrlash shovqin darajasini pasaytirish va EKG elementi tan oluvchining yanada ishonchli ishlashi uchun zarur bo'lgan algoritm va dasturiy ta'minot filtrlarining quyidagi turlari haqida ma'lumot keltirilgan.

**Kalit so'zlar:** Elektrokardiografiya, signalni qayd qilish, matematik modellashtirish, axborotli xususiyatlar, sinflash, aritmiyalarni tashxislash.

**Аннотация.** Одним из эффективных способов предотвращения смерти от сердечного приступа от Всемирной организации здравоохранения является своевременная диагностика на основе современных алгоритмов цифровой обработки электрокардиографических (ЭКГ) сигналов. Сегодня для повышения эффективности диагностики сердечно-сосудистых заболеваний разработан ряд методов автоматического обнаружения электрокардиографических сигналов. Использование компьютерных технологий и математических моделей для записи, распознавания и расчета основных параметров различных медицинских явлений в

регистрируемом сигнале, а также для создания в них различных медицинских систем, выполняющих функции вплоть до попыток внедрения консультативных подсистем, а также диагностики состояния здоровья, приводит к выработке выводов. В исследовании рассматривается процесс записи сигналов ЭКГ, реализация алгоритмической и программной разработки на основе схемы разделения в численном решении и раскрытия во времени. Процесс получения информации осуществляется путем выбора указанных по определенным критериям “информативных” признаков и классификации выбранных разделов по описанию представления их в виде кривой классификации. В данной статье представлена информация о следующих видах алгоритмических и программных фильтров, необходимых для снижения уровня шума фильтрации сигнала ЭКГ и более надежной работы распознавателя элементов ЭКГ.

**Ключевые слова:** Электрокардиография, регистрация сигналов, математическое моделирование, информативные признаки, классификация, диагностика аритмии.

**Abstract.** One of the effective ways to prevent death from heart attack from the World Health Organization is timely diagnosis based on digital processing algorithms of modern electrocardiographic (ECG) signals. Today, a number of methods for automatic detection of electrocardiographic signals have been developed to improve the efficiency of diagnosing cardiovascular diseases. Using computer technologies and mathematical models, creating various medical systems that perform functions ranging from recording, recognizing and calculating the main parameters of various medical events in the recorded signal, and making conclusions, to attempts to implement advisory subsystems in them, as well as diagnoses about the state of health leads to the development of conclusions. In the study, the process of recording ECG signals, separation in numerical solution and implementation on the basis of a time-undisclosed scheme, algorithmic and software development are discussed. The process of obtaining information is carried out by selecting the “informative” features indicated by certain criteria and presenting them as a classification curve to classify the selected sections. The study considers the process of recording ECG signals, separation in numerical solution and implementation in time based on an undisclosed scheme, algorithmic and software development. The process of obtaining information through the selection of “informative” properties specified by certain criteria and the description of presenting them as a classification curve, the grading of selected sections has been carried out.

**Keywords:** Electrocardiography, signal recording, mathematical modeling, informational properties, grading, diagnosis of arrhythmias.

## Introduction

Information technology in medicine is a branch of scientific science that studies medical biological, clinical and preventive issues based on the processes of recording,

transmitting, storing, processing, distributing and presenting information using information communication systems and technologies in medicine and healthcare. The object of study of information technologies in medicine is information technologies implemented at various organizational levels in medicine and health care, mainly from the many methods of functional research of the cardiovascular system, electrocardiography (ECG) has been used not only for its clinical use over the years. not only increasing its position, but also finding more and more wide areas of application. Today, several effective electrocardiographic methods are used to analyze heart activity, such as resting ECG, stress ECG, and daytime activity monitoring studies, etc. All of them have different diagnostic value in the search for certain pathologies and, as a rule, complement each other [1].

### **Literature Review**

Digital signal filtering and processing methods widely covered in the world scientific literature are provided by J.Pan, J.Tompkins, N.K.Smolentsev, P.S.Addison, S.Malla, A.Oppenheim, A.V.Merkusheva, F.Crea, P.Samici, R.Decatrina and others. scientific research is devoted to the improvement of biosignal processing algorithms and tools. Scientific works on the creation of a hardware and software complex in real time, effective algorithms for digital signal processing and transmission R. Hemming, S. D. Kurgalin, D. Dazhion, K. Blatter, Ya. A. Turovsky, I. Yu. Kretinin, S. M. Arbuzov, I.S. Gubarev, A.V. Maksimov and a number of other scientists' scientific articles.

The main scientific works of scientists and researchers of our republic V.K. Kabulov, B.N. Khidirov, M.M. Musaev, A. Abduqayumov, Kh.N. Zaynidinov, S. Sayidaliev, J.Kh. Djumanov, B.B. Mominov, O'R. Hamdamov, F.F. Rajabov, R. Nasimov and others who have contributed to research in the field of digital processing of biomedical signals and diagnosis based on identified indicators.

### **Research Methodology**

An integral part of the field of cardiology is the analysis and evaluation of ECG signals, and in one way or another, the use of personal computers and specialized microprocessor systems to implement methods based on the use of complex modern mathematical algorithms for processing and presenting medical signals received from the patient has a positive effect on its development. is showing.

The power of current computer systems allows to separate and recognize individual events in the ECG and organize their mathematical processing not only with the help of personal computers, but also with the help of microprocessor controllers installed in ECG reading devices. This allows not only to conduct examinations more efficiently, accurately and in a short time, but also to improve the working conditions of the doctor when performing routine methods related to the measurement of parameters and detection of events [1, 2].

### **Analysis and Results**

Using computer technologies and mathematical models, creating various medical systems that perform functions ranging from recording, recognizing and calculating



the main parameters of various medical events in the recorded signal, and making conclusions, to attempts to implement advisory subsystems in them, as well as diagnoses about the state of health leads to the development of conclusions.

The problem of mathematical modeling can be expressed as  $G$ - the area with a smooth boundary of the field  $\partial G$ ,  $\varphi_e$ - electric potential except for the skin tissue,  $v_{tm}$ - transmembrane voltage can be described by following:

$$\mu \left( K_m \frac{\partial v_{tm}}{\partial t} + L_n(u, v) \right) - \nabla \cdot (\sigma_i \nabla (v_{tm} + \varphi_e)) = I_i, \quad v, u \in G$$

$$\nabla \cdot ((\sigma_i + \sigma_e) \nabla \varphi_e + \sigma_i \nabla v) = -I_{total},$$

*In G*                      *f(u, v)*

where,  $K_m$ - is the specific electric capacity of the membrane of the skin tissue,  $\mu$ - is the ratio of the area of the skin tissue to the volume,  $\sigma_i$  and  $\sigma_e$  - are the conductivity sensors inside the skin tissue and outside the tissue,  $I_i$  - electric current source inside the skin tissue,  $I_{Total} = I_i + I_e$  is the total current source,  $u$  - is the vector of phase variations,  $L_n(u, v)$  and  $f(u, v)$  - are given functions describing the model representing the skin tissue.

The initial conditions and boundary conditions are given as follows:

$$\begin{aligned} n \cdot (\sigma_i \nabla (v_{tm} + \varphi_e)) &= 0 & \partial G - da \\ n \cdot (\sigma_e \nabla \varphi_e) &= n \cdot (\sigma_b \nabla \varphi_e) = 0 & \partial G - da \\ \nabla \cdot (\sigma_b \nabla \varphi_e) &= 0 & \partial G_b - da \\ n \cdot (\sigma_b \nabla \varphi_e) &= I_e^{surface} & \partial G_b / \partial G - da \end{aligned}$$

where  $I_e^{surface}$  is the current source at the border of the outer region.

When analyzing the results of the obtained electrocardiogram, the necessary information is considered to be present in the sections of the curve called cardiac complexes, such as P-, Q-, R-, S-, T-waves. In this case, in the process of obtaining information from the curve, it is necessary to select and classify the “informative” sections indicated by certain criteria, and the classes of the selected sections through the description of the presentation of information about the curve as a whole should be built. In such a description, the names (indices, numbers) of classes of sections play the role of “letters”, and the sequence of these indices can be understood as “characters” of a certain language. Using this language, individual curves are analyzed, and only then the entire set of curves describing the behavior of the object in question is analyzed. This process of obtaining information to a certain extent shows a general approach to the study of graphical lines experimentally developed by practical experts in the process of visual analysis of curves [3, 4].

Before conducting such an analysis, it is necessary to carry out preliminary processing of the received data, that is, filtering and isolation correction.

Filtering of the ECG signal is necessary to reduce the level of noise and for more reliable operation of the ECG element recognizer, the following types of algorithm and software filters are used: recursive digital filter; filtering in the frequency domain; moving average filter low-pass spline filter.

If we describe these filters in more detail, in a recursive filter, not only the input, but also the previous output values coming through the feedback loop are used to calculate the output parameters. Such a filter gives much higher attenuation values, but causes large phase distortions and has a very large unevenness in the transparency zone.

In frequency domain filtering, the signal is filtered in a certain frequency range using a discrete Fourier transform  $S(j)$  corresponding to frequencies  $0, 1/T, 2/T, \dots, (N-1)/T$  from the set of signals  $y(k)$  coefficients are calculated, where  $T$  is the signal selection time. After multiplying the coefficients by the frequency response values, an inverse transformation is performed that restores the filtered signal. In theory, this is the most universal filtering method, but it requires a large amount of calculations (about  $4*n*log(n)$  addition and multiplication operations) and is not efficient to use without hardware accelerators. A 50 Hz adaptive notch filter is used to suppress network noise; for anti-tremor filtering, a moving average cosine filter with a frequency of 35 Hz and a zero-phase shift is used; A low-pass spline filter is used to filter the P-wave and ST-interval sections.

The low-pass spline filter has the best shape of the response in the transparency zone and the highest slope of the amplitude-frequency response. Its disadvantages include a significant phase error and a large number of calculations (each time a system of linear equations with a linear matrix of the order of the sample size is solved).

A moving average filter is considered the simplest, and it involves the weighted sum of  $n+1$  samples of the input signal with respect to the current sample. Moreover, if the weighting coefficients are symmetric with respect to  $y(i)$ , i.e.  $w(i)=w(-i)$ , then such a filter does not cause phase distortion. Its disadvantages include relatively small attenuation values in the filtering region. The task of recognizing the elements of ECG signals is to find and implement a method(s) of automatically constructing a language for describing experimental curves. This method allows you to efficiently develop a language that is specially adapted for the analysis of certain types of data. At the first stage of the analysis, an alphabet (benchmark, set of standards) is automatically created, which is then used to classify the newly identified areas of information, and the process of identifying these areas does not require the presentation of a significant amount of information a priori. According to the current method, small areas where the curve changes significantly are identified first. This approach divides the curve into segments, in each of which the curve moves relatively smoothly, and is called a segmentation process, and these sections are a transition process. Then the alphabetization step continues, for example, from the language of standard forms specified by the compiler or based on standard forms that are automatically constructed, each time a new class of learned curves is presented for description. In the automatic method of creating a set of standards, during the segmentation step, the machine creates a series of all selected transition sections. Then, for each array, a feature vector describing the “shape” of the curve movement in the considered transition is determined [4, 5].

Such a set of vectors, in turn, is classified into classes of close vectors according to some predetermined criteria, in the sense of the similarity of vector properties. Each class of “similar” vectors (or transition sections) obtained as a result of applying the

classification algorithm is understood as a token of the generated language. Any transition partition can be assigned to one of the selected classes using any graph detection algorithm. In this sense, it is possible to understand the identified classes as an alphabet and name the transitions using them. The next step is indexing the curve, which means that the curve is represented as a sequence of letters in the constructed alphabet. The default descriptions of the curves constructed in this way can be used to compare the curves with each other - either the presence of a certain symbol in the image of the curve or the order of the letters of the alphabet (there can be several letters) - will be selected for the specification.

Each lead electrode is a recording of the electrical activity of the heart muscle at a certain time interval, and determines whether there is a fixed relationship between the ECG signal and the heart's activity. Cardiac arrhythmias are very clearly expressed in the ECG, and the quality of automatic diagnosis of arrhythmias largely depends on the quality of recording and processing of electrocardiosignals. In this case, the effect of "accumulation of errors" is observed, which requires the analysis of arrhythmias to be only in a simplified form.

Missing and misdiagnosing QRS complexes can significantly reduce diagnostic quality. These errors occur in conditions of interference during registration, as well as due to difficulties in distinguishing images of different parts of the cardiac cycle of a pathological ECG (for example, it is difficult to distinguish a T-wave from an early ventricular extrasystole). In the automatic diagnosis of arrhythmias, it is difficult to detect low-amplitude ECG P-waves in real time, which especially affects the analysis of complex cases of combined types of arrhythmias. A big part of automated arrhythmia diagnosis is recognizing life-threatening arrhythmias. The small amount of time (up to 10 seconds) available for detecting these patterns and the very strict requirements for both types of diagnostic errors make it difficult to automate this task.

It is especially important to recognize emergency contractions of the heart ventricles, which begin with foci of excitation in the ventricles themselves (ectopic contractions). They are of great prognostic value and are manifested in the form of various ventricular extrasystoles and episodes of paroxysmal ventricular tachycardia. In addition, it is necessary to constantly monitor their dynamics during antiarrhythmic therapy. On the ECG, these arrhythmias are mainly manifested in the form of characteristic changes in the shape of the QRS complex and the sequence of RR intervals, so it is very good to take these signs into account with the diagnostic algorithm.

Features of construction of algorithms for automatic diagnosis of arrhythmias, and in the first step of this algorithm, each current RR interval  $Trr_i$  is divided by the next  $Trr_{(i+1)}$ . The result of this division is quantized in 5 levels according to the rule  $g_i = Trr_i / Trr_{(i+1)}$ :

$$Z_i = \begin{cases} 1, & \text{if } g_i \geq 1.2 \\ 2, & \text{if } 1.2 > g_i \geq 1.1 \\ 3, & \text{if } 1.1 > g_i \geq 0.9 \\ 4, & \text{if } 0.9 > g_i \geq 0.8 \\ 5, & \text{if } g_i > 0.8 \end{cases}$$

where  $Z_i$  is the rank number resulting from the change of the  $i$ -th RR-interval.

The notation  $Z_2=5$  means that the ratio  $g_2 = Trr_2/Trr_3$  belongs to the 5th quantization level. To identify certain types of arrhythmias, the 1st sublevel is introduced, called the sixth, and is defined as follows:  $g_i \geq 1.4$  when  $T_t \leq 200$  ms;  $Z_i=6$  if  $Trr_i \geq 4,9$   $Trr_{i+1}-500$  ms,  $Trr_i \geq 200$ .

If a certain QRS complex is designated by  $R_0$ , then the analyzed complexes after it are designated as  $R_1, R_2, R_3$ , etc. As a result of the QRS complex shape classification algorithm, each complex is given a certain level  $M$ . The value of  $M=1$  corresponds to the normal form,  $M=2$  to the pathologically changed (ventricle) form. When  $M=0$  or  $M=3$ , the algorithm gives an ambiguous answer. Therefore, the inscription  $M_1=1$  means that the complex  $R_1$  has a normal form. All complexes for a normal ECG are like this. Based on the characteristic changes in the RR intervals and the related dynamics of the QRS complex shape, the algorithm determines the appearance of short-term arrhythmic events, and then, taking into account the determined rhythmicity of the heart contraction, takes into account the heart rate and possible changes. It forms a final diagnosis based on the sequence of these events in a certain time interval (time of analysis) in the form of a ventricular complex in the entire  $t_a$  interval. Detection of event-type arrhythmias is carried out when the conditions of the current mode are met, which are expressed in the form of logical formulas, the truth of which means the occurrence of the corresponding events, the following events and preliminary diagnoses are determined, in particular, the solitary extrasystole above the ventricle ( $S_1$ ) can be written as follows:

$$S_1 = \{(Z_1 = 1) \wedge (Z_2 = 5) \wedge (M_1 = 1) \wedge (M_2 = 1) \wedge (M_3 = 1)\};$$

early extrasystole above the ventricle ( $S_2$ ) can be expressed as follows:

$$S_2 = \{(M_1 = 1) \wedge (M_2 = 2.3) \wedge (M_3 = 1) \wedge (Z_1 = 6) \wedge [(Z_2 = 5) \vee (Z_2 = 5)]\};$$

paired ventricular extrasystole ( $S_3$ ) is as follows:

$$S_3 = \{(M_1 = 1) \wedge (M_2 = 2.3) \wedge (M_3 = 2.3) \wedge (M_4 = 1) \wedge (Z_1 = 1,2,6)\};$$

a complete list of possible arrhythmias, etc.

In the analysis of the contour analysis algorithm, the characteristic elements of the cardiocycle are identified, it is the basis for understanding the causes of deviations from the norm and making decisions about possible ways to eliminate them. Each complex contains several different oriented dental cusps, and the number of cusps varies in different directions and in different patients. P- and T-complexes usually contain one

or two waves, and the QRS complex - one to seven. Characteristic elements of ECG analysis are complexes, segments and intervals. Thus, the problems of segmentation, recognition and analysis of experimental data arise.

We can divide the task of recognizing and measuring the characteristic elements of the ECG signal into six successive steps:

- a) determination of real peaks;
- b) finding upper bounds;
- c) recognize the highest point;
- d) recognition of ECG elements;
- e) classification of complexes;
- f) Interpretation of ECG and its classification.

As can be seen from the above, there is a need to use such methods as spectral analysis methods, structural-linguistic methods of information processing, and image recognition methods.

In parts (a) and (b), it is recommended to use the above classification algorithms, which use the formalization of intuitive and easily separable representations of simple and complex signal states. Then, using the selected lines, construct an alphabet (part (c)) and divide them into classes of "similar" vectors, and these classes represent an alphabet naming transition region (elements of the ECG signal: P, Q, R, S, T). Then, curve indexing makes sense (part (d)), i.e., the ECG signal is represented as a structured alphabetic sequence P, QRS, T (part (e)). As a rule, the most prominent element of the ECG is the QRS complex, and these complexes should be classified according to their configuration (part (f)).

It should be noted that the complex contains up to seven peaks, the beginning, end and other parameters of the complex can be easily determined by knowing the parameters of the individual signal elements, that is, the letters of the constructed alphabet, the classification is carried out based on the "detection/classification" method is increased, according to which it is expressed as a set of formal properties, such as the coordinates of a set of complex orthonormal vectors, or in the form of corresponding heuristic symbols. In this case, the time of analysis and calculations is significantly reduced. These characteristics usually include the amplitude of the complex, its width, the average deviation from the zero line, the area, the time interval between the peaks, etc. So, it can be expressed as a set of parameter-coordinates of complex data vectors:  $\{QRS_1, QRS_2, \dots, QRS_n\}$ . They are divided into  $m$  classes:  $\{S_1, S_2, \dots, S_m\}$  are determined using the classification algorithm based on the closest values as follows: 1) assignment of  $QRS_j$  complex to class  $S_j$ ;  $j=1, m=1$ ; 2) increase  $j$  by 1 and calculate  $D = \min d(S_j, QRS_j)$ , where:  $d(S_j, QRS_j)$  is the standard distance between class  $S_j$  and  $QRS_j$  complex. When the distance is minimal,  $i=1$  is set, if  $D \leq t$  ( $t$  is some critical value at which the division into classes is made),  $QRS_j$  belongs to the class  $S_j$ , otherwise they form a new class and  $m$  is set to 1 increases to; 3) repeats step 2 until all complexes are divided into classes [5].

Normalization in calculations is used in the sense that the universality of calculations does not depend on scaling. In addition to the detection of arrhythmic events, the characteristics of the morphology of QRS complexes, the frequency and rhythm of heart contractions are determined in the entire time interval (the usual value of  $t_a$  is 1 minute) to form the final diagnostic conclusions. These features include: normal form of QRS complexes (NF); NF= (for time  $t_a$  all QRS complexes  $M=1$

condition is fulfilled); abnormal form of all QRS complexes (AF); AF= (for time  $t_a$  all QRS complexes M=2 conditions are fulfilled); polymorphism feature (MF); MF= (for  $t_a$  standards of QRS complexes, M=2 different indices occur at least once).

Depending on the heart rate frequency, the following classes are distinguished: bradysystole (BR): $BR=(40\leq CHSSB60)$ ; normosystole (NR): $NR=(60\leq CHSSB90)$ ; tachysystole (TL): $TL=(90\leq CHSSB120)$ ; severe tachysystole (TH): $TH=(120\leq CHSS)$ .

Heart arrhythmia classes are classified as follows: mild arrhythmia (AL): $AL=(N_2/N_3 < 25)$ ; average arrhythmia (FL): $AL=(\lfloor 0.25 < N \rfloor_2 / N_3)$ ; severe arrhythmia (AH): $AH=((N_2+N_1)/(N_3 < 0.55))$ ; where  $f_1, f_2, f_3$  are the number of events  $N_1, N_2, N_3$  that occurred at time.

$$f_1 = (Z_2 = 2) \vee (Z_1 = 4), f_2 = (Z_1 = 3), f_3 = (Z_i = 1) \vee (Z_i = 5) \vee (Z_i = 6)$$

## Conclusions

In conclusion, it should be said that the frequency of occurrence of any arrhythmic events, or the fact of their occurrence in general, is formed as a combination of the morphology, frequency and rhythmic properties of the heart's ventricular complexes. Final diagnoses include frequent supraventricular extrasystoles, if they are more than 6 in 1-minute, frequent ventricular extrasystoles, if their number is more than 6 in 1 minute, as well as frequent loss of the QRS complex, if this number of losses exceeds 1 minute 5.

Separately, with the development of the appropriate diagnosis, the facts of the occurrence of early, paired and group extrasystoles are recorded at least once. If the shape of the QRS complex differs in at least two extrasystoles that appear after time  $t_a$ , then the algorithm makes a diagnosis of polymorphic extrasystoles

## References:

- [1] Raximova F.B., Raximov B., Axmedov J., Saidov A., "Elektrokardiografiya qurilmasidan olingan ma'lumotlarni raqamli qayta ishlash", -Urgench city: *Ilm sarchashmalari*, ilmiy- metodik jurnal, 2019, pp. 17-20.
- [2] Rakhimov B.S., Sobirova S.K., Akhmedov J., Rahimova F.B., Saidov A.B., "Spectral analysis of medical signals on the of polynomial walsh bases", Indiya, *EPRA International Journal of Multidisciplinary Research*, Vol.: 6, Issue: 2, 2020, pp. 538-539.
- [3] Rakhimov B. S., Sobirova Q.Q., Rahimova F.B., "Development of algorithms spectral analysis of medical signals on the polynomial walsh bases", city Ufa, *Nauchniy progress*, №11, 2018, pp. 38-39.
- [4] Raximov B., Sobirova S., Raximova F.B., "Tibbiyotda axborot texnologiyalarini qo'llash", -Urgench: *Ilm sarchashmalari*, ilmiy- metodik jurnal, №1, 2019, pp. 25-29.
- [5] Rakhimov B.S., Rahimova F.B., Sobirova S.K., Kuryazov F.O., Abdirimova D.B., "Review and Analysis of Computer Vision Algorithms", *The American Journal of Applied sciences*, May 31, 2021, pp. 245-250.
- [6] Rakhimov B.S., Sobirova S.K., Rakhimova F.B., Allayarova A.A., Saidov A.B., and Saidova Z.B., "Comparative analysis of the implementation of



parallel algorithms on the central processors of automation systems in agriculture”, *E3S Web of Conf.* June, 2023.

UDC: 51,510.6,517.9

## INVERSE MATRIX METHOD FOR CALCULATING MODELS OF STABLE ELECTRICAL SYSTEMS UNDER CONDITIONS OF INTERVAL DATA UNCERTAINTY

**Tokhirov Feruz Jamoliddinovich,**

*Senior teacher PhD,*

*Navoi State Pedagogical Institute*

[toxirovferuz90@gmail.com](mailto:toxirovferuz90@gmail.com)

**Isroilova Lola Sunnatovna**

*Senior teacher PhD,*

*Navoi State Pedagogical Institute*

[lola.isroilova.90@mail.ru](mailto:lola.isroilova.90@mail.ru)

**Annotatsiya.** Ushbu maqolada elektr tizimlarida oqimlar va kuchlanishlarning taqsimlanishini aniqlash uchun teskari matritsani topishning iterativ texnikasi usullari keltirilgan va uning intervalli kompleks raqamlari doirasidagi konvergensiyasiga e'tibor qaratilgan. Shuningdek, interval matritsasining spektral radiusidan foydalangan holda konvergensiyani baholash qo'llanilgan.

**Kalit so'zlar:** teskari matritsa, intervalli noaniqlik, kompleks intervallar, usul yaqinlashuvi.

**Аннотация.** В исследовании исследуется итеративный метод нахождения обратной матрицы для определения распределения токов и напряжений в электрических системах, ориентируясь на ее сходимость в области интервальных комплексных чисел. Оценка сходимости получается с использованием спектрального радиуса интервальной матрицы.

**Ключевые слова:** обратная матрица, интервальная неопределенность, комплексные интервалы, сходимость метода.

**Abstract.** The study explores the iterative technique of finding the inverse matrix to determine the distribution of currents and voltages in electrical systems, focusing on its convergence within the domain of interval complex numbers. An estimation of convergence is derived, utilizing the spectral radius of the interval matrix.

**Keywords:** inverse matrix, interval uncertainty, complex intervals, method convergence.

### Introduction

Steady state computations are essential for addressing issues related to the design and operation of electrical systems [1]. These computations play a pivotal role in

planning operational strategies, serving as the foundation for optimization, stability, and reliability analyses. Recently, techniques incorporating imprecise technological data, such as probabilistic, fuzzy, and interval methods, have seen increased application in concrete mathematical modeling. Many existing methods utilized for computing modes and power losses in networks of various voltage levels rely on deterministic representations of the original data, thus making specific assumptions. However, the initial data available for these computations often exhibit uncertainty, stemming from incompleteness, limited reliability, or inherent variability in parameter values and operating conditions. This uncertainty can arise due to natural dispersion, changes during operation, measurement errors, or other factors. Probabilistic and statistical methods for computing modes and electricity losses often fail to adequately address these uncertainties in the source data. Moreover, the deterministic results obtained from these calculations do not capture the potential ranges of variation in mode variables. The adoption of probabilistic-statistical methods typically necessitates a substantial amount of statistical data and the development of complex models, introducing additional uncertainty. In contrast, the interval approach offers a means to rigorously formulate numerical algorithms while accounting for the interval uncertainty associated with parameter values and operating conditions in electrical systems [2].

In tasks concerning the determination of optimal configurations for networks containing traction loads, a considerable number of flow distribution computations are imperative [1]. The outcomes of these computations enable us to address several critical questions, including:

1. Whether the system configuration is viable;
2. Whether the voltage levels at the nodal points remain within specified thresholds.

Significant challenges arise when computing the parameters of configurations in intricate network circuits featuring numerous nodes and branches. The execution of such calculations becomes intricate due to the involvement of complex higher-order matrices and extensive systems of nonlinear equations. Compounding these difficulties is the possibility of obtaining solutions that satisfy the system but fail to meet physical requirements. Consequently, despite the availability of certain algorithms for computing energy systems, both domestically [1, 2] and internationally [3, 4], the quest for more efficient calculation methodologies persists. This research endeavors to address these challenges.

**NOTATION AND BASICS.** In this presentation, we adhere to the notation outlined in the preliminary non-formal international standard for interval values [5]. Specifically, interval values are denoted in bold within the text, while non-interval values are not differentiated in any manner. In interval analysis, rectangular and circular complex intervals are commonly employed as representations of complex intervals. The corresponding sets are denoted by  $\mathbf{IC}_{\text{rect}}$  and  $\mathbf{IC}_{\text{circ}}$ . Below we will consider the intervals only from  $\mathbf{IC}_{\text{rect}}$  and below, for brevity, we denote this set simply  $\mathbf{IC}$ :

$$\mathbf{a} = \mathbf{a}_1 + i\mathbf{a}_2 = \{a = a_1 + ia_2 \in \mathbf{C} | a_1 \in \mathbf{a}_1, a_2 \in \mathbf{a}_2\}$$



for material intervals  $\mathbf{a}_1, \mathbf{a}_2 \in \mathbf{IC}$ .

Interval number  $\mathbf{a} = [\underline{a}, \bar{a}] \in \mathbf{IR}$  is characterized with several functions [6].

- Middle (centre) mid  $\mathbf{a} = \frac{1}{2}(\underline{a} + \bar{a})$  [6, 7];
- Radius rad  $\mathbf{a} = \frac{1}{2}(\underline{a} - \bar{a})$  [6, 7];
- Width wid  $\mathbf{a} = \underline{a} - \bar{a}$  [6, 7];
- Maximal size

$$|\mathbf{a}| := \max\{|a| | a \in \mathbf{a}\} = \max\{|\underline{a}|, |\bar{a}|\} \text{ and etc [6, 7].}$$

Similarly, to the real case, we introduce the corresponding functions for complex intervals:

**Definition 1.** Let  $\mathbf{a} = \mathbf{a}_1 + \mathbf{a}_2 \in \mathbf{IC}$ . Then the value is  $|\mathbf{a}| = |\mathbf{a}_1| + |\mathbf{a}_2|$  called the absolute value or modulus of the interval  $\mathbf{a}$  [8].

**Definition 2.** Let  $\mathbf{a} = \mathbf{a}_1 + i\mathbf{a}_2 \in \mathbf{IC}$ . Then the width of the interval  $\mathbf{a}$  will be called the value  $wid \mathbf{a} = wid \mathbf{a}_1 + wid \mathbf{a}_2$  [8].

We introduce the Hausdorff metric [1] in space  $\mathbf{IC}$ .

**Definition 3.** Let  $\mathbf{a} = [a_1, a_2], \mathbf{b} = [b_1, b_2] \in \mathbf{IR}$ . Then the distance between the elements  $\mathbf{a}$  and  $\mathbf{b}$  is introduced as follows:

$$\text{dist}(\mathbf{a}, \mathbf{b}) := \max\{|a_1 - b_1|, |a_2 - b_2|\} \text{ [9].}$$

**Definition 4.** Let  $\mathbf{x} = [x_1, x_2], \mathbf{y} = [y_1, y_2] \in \mathbf{IR}^n$ . Then the metric on the multidimensional interval space for vectors  $\mathbf{x}$  and  $\mathbf{y}$  is defined as:

$$\text{dist}(\mathbf{x}, \mathbf{y}) := \max\{\|x_1 - y_1\|, \|x_2 - y_2\|\}$$

where  $\|\cdot\|$  is the absolute vector norm on  $\mathbf{R}^n$ .

**Definition 5.** Let  $\mathbf{x} = \mathbf{x}_1 + i\mathbf{x}_2, \mathbf{y} = \mathbf{y}_1 + i\mathbf{y}_2 \in \mathbf{IC}^n$ . Then the metric  $\mathbf{IC}^n$  on space for vectors  $\mathbf{x}$  and  $\mathbf{y}$  is determined by the relation:

$$\text{dist}(\mathbf{x}, \mathbf{y}) := \text{dist}(x_1, y_1) + \text{dist}(x_2, y_2) \text{ [10]}$$

**Definition 6.** An interval mapping

$f: \mathbf{IC}^n \rightarrow \mathbf{IC}^n$  is called  $P$ -compression (or  $P$ -compressor) if there exists a non-negative  $n \times n$ -matrix  $P$  with a spectral radius  $\rho(P) < 1$  such that for all  $\mathbf{x}, \mathbf{y} \in \mathbf{IC}^n$ .

$$\text{dist}(f(\mathbf{x}), f(\mathbf{y})) \leq P \cdot \text{dist}(\mathbf{x}, \mathbf{y}) \text{ [10]}$$

**Proposition 1.** For any interval matrices

$\mathbf{A}, \mathbf{B}, \mathbf{C} \in \mathbf{IC}^{n \times n}$  and interval vectors  $\mathbf{b}, \mathbf{c} \in \mathbf{IC}^n$ , the following easily provable properties hold [7]:

$$\begin{aligned} \text{dist}(\mathbf{A} + \mathbf{C}, \mathbf{B} + \mathbf{C}) &= \text{dist}(\mathbf{A}, \mathbf{B}), \\ \text{dist}(\mathbf{A} + \mathbf{B}, \mathbf{C} + \mathbf{D}) &= \text{dist}(\mathbf{A}, \mathbf{C}) + \text{dist}(\mathbf{B}, \mathbf{D}) \\ \text{dist}(\mathbf{AB}, \mathbf{AC}) &\leq |\mathbf{A}| \cdot \text{dist}(\mathbf{B}, \mathbf{C}) \\ \text{dist}(\mathbf{Ab}, \mathbf{Ac}) &\leq |\mathbf{A}| \cdot \text{dist}(\mathbf{b}, \mathbf{c}) \end{aligned}$$

## Formulation of the Problem

The challenge of establishing steady-state conditions in electric power systems involves solving a system of nonlinear algebraic equations with complex coefficients [1,

2]. These equations interlink the currents and voltages at various nodes within the network:

$$\sum_{j=1}^n a_{ij}x_j = \frac{s_i}{x_i} - a_{i0}x_0, \quad i = 1, 2, \dots, n. \quad (1) \quad [10]$$

Here  $a_{ij}$  are the elements of the complex matrix own and mutual conductivities of the system,  $s_i$  - is the power value at the  $i$  node,  $x_i$  is the column vector of stresses at a node and is complex conjugate number for  $x_i$ ,  $a_{i0}$  is a matrix conductivity of node communication branches balancing with other nodes, and  $x_0$  is voltage balancing unit.

The parameters of the balancing node  $a_{i0}$ ,  $x_0$  is considered to be given, but they can change in the process of solving a more general problem. System (1) is "sparse" in the sense that most of the coefficients  $a_{ij}$  are zero. They are nonzero if the  $i$  and  $j$  nodes of the network are directly connected.

We proceed to represent system (1) in interval form, aligning with mode parameters characterized by interval uncertainty:

$$\sum_{j=1}^n a_{ij}x_j = \frac{s_i}{x_i} - a_{i0}x_0, \quad i = 1, 2, \dots, n. \quad (2) \quad [10]$$

Denoting the left side of the last system by  $F(\mathbf{a}, \mathbf{x})$ , we can write it in a short form  $F(\mathbf{a}, \mathbf{x}) = \mathbf{s}$  for  $\mathbf{a} \in \mathbf{a}, \mathbf{s} \in \mathbf{s}$ .

For system (3), the united set of solutions is the set

$$\mathcal{E}(F, \mathbf{a}, \mathbf{s}) = \{x \in \mathcal{C} | (\exists a \in \mathbf{a})(\exists s \in \mathbf{s})(F(a, x) = s)\},$$

and below we will consider the problem of its external interval estimation [12].

Thus, our goal is to find, if possible, the best (i.e., the least by inclusion) interval vector that limits the set of solution  $\mathcal{E}(F, \mathbf{a}, \mathbf{s})$  in the interval complex space.

When tackling the resolution of system (2), encountering challenges arises due to the complexity of handling high-order complex interval matrices and extensive sets of nonlinear equations. For nonlinear equation systems, employing iterative solution techniques is customary. In such scenarios, the iterative process's structure plays a crucial role, impacting the ease of implementation, convergence rate, and the quality of the interval solution obtained.

### Interval Method Inverse Matrix

The inverse matrix interval method is derived from relations (1), hence the computation is conducted following the formula.

$$\mathbf{x}^{(k+1)} := \mathbf{x}^{(k)} \cap \mathbf{A}^{-1} \mathbf{y}^{(k)}, \quad (3)$$

$$A = \begin{pmatrix} a_{11} & a_{12} & \dots & a_{1n} \\ a_{21} & a_{22} & \dots & a_{2n} \\ \vdots & \vdots & \ddots & \vdots \\ a_{n1} & a_{n2} & \dots & a_{nn} \end{pmatrix}, \quad \mathbf{y}^{(k)} = \begin{pmatrix} s_1 / \mathbf{x}_1^{(k)} - a_{10}x_0 \\ s_2 / \mathbf{x}_2^{(k)} - a_{20}x_0 \\ \vdots \\ s_n / \mathbf{x}_n^{(k)} - a_{n0}x_0 \end{pmatrix} \quad [7].$$

where  $\mathbf{x}^{(k)}$  and  $\mathbf{x}^{(k+1)}$  - the values of the components of the interval solution  $\mathbf{x}$ , vector, respectively, at the  $k$  and  $(k+1)$  iteration. The iterative calculation continues according

to formula (3) until the condition  $\text{dist}(\mathbf{x}^{(k)}, \mathbf{x}^{(k-1)}) < \varepsilon$  is satisfied, where  $\text{dist}(\cdot, \cdot)$  is the Hausdorff metric [12] in space  $\mathbf{IC}^n$ ,  $\varepsilon$  is the required accuracy.

In classical interval arithmetic, subtraction is not an operation inverse to addition, therefore, in  $\mathbf{IC}$ , along with the usual operation of subtracting intervals, we introduce the full Kaucher interval arithmetic [2] (where the “ $\ominus$ ” sign means non-standard subtraction):

$$\mathbf{a} \ominus \mathbf{b} = (\mathbf{a}_1 + i\mathbf{a}_2) \ominus (\mathbf{b}_1 + i\mathbf{b}_2) = (\mathbf{a}_1 \ominus \mathbf{b}_2) + i(\mathbf{a}_2 \ominus \mathbf{b}_1) =$$

$$[\min\{\underline{a}_1 - \underline{b}_2, \bar{a}_1 - \bar{b}_2\}, \max\{\underline{a}_1 - \underline{b}_2, \bar{a}_1 - \bar{b}_2\}] + i[\min\{\underline{a}_2 - \underline{b}_1, \bar{a}_2 - \bar{b}_1\}, \max\{\underline{a}_2 - \underline{b}_1, \bar{a}_2 - \bar{b}_1\}] \quad [7]$$

Then, by (2), we have

$$\text{dist}(f(x), f(y)) = \text{dist}(\mathbf{A}^{-1} \mathbf{D} \mathbf{x}, \mathbf{A}^{-1} \mathbf{D} \mathbf{y}) = \text{dist}(\mathbf{A}^{-1} \mathbf{x}, \mathbf{A}^{-1} \mathbf{y}) + \text{dist}(\mathbf{D} \dot{\mathbf{x}}, \mathbf{D} \dot{\mathbf{y}}) \leq$$

$$\leq |\mathbf{A}^{-1}| \cdot \text{dist}(x, y) \cdot |\mathbf{D}| \cdot \text{dist}(\dot{x}, \dot{y}) = (|\mathbf{A}^{-1} \mathbf{D}|) \cdot \text{dist}(x, y). \quad [8]$$

It follows from Theorem 1 from [1] that the condition  $\rho(|\mathbf{A}^{-1} \mathbf{D}|) < 1$  is sufficient for the convergence of the method and the uniqueness of a fixed point.

*Need.* We assume that successive

$$\mathbf{A} \mathbf{x}^{(k+1)} \ominus \mathbf{A} \mathbf{x} = \left( \frac{s_i}{\dot{x}_i^{(k)}} - a_{i0} x_0 \right) \ominus \left( \frac{s_i}{\dot{x}_i} - a_{i0} x_0 \right),$$

hence,

$$\mathbf{A}(\mathbf{x}^{(k+1)} \ominus \mathbf{x}) = -\frac{s_i}{\dot{x}_i \dot{x}_i^{(k)}} (\dot{x}_i^{(k)} \ominus x_i). \quad (4)$$

Further, using the notation  $\mathbf{z}^{(k)} = \mathbf{x}^{(k)} \ominus \mathbf{x}$ , we obtain an iterative formula: where  $\mathbf{z}^{(k+1)} = \mathbf{A}^{-1} \mathbf{D}^{(k)} \mathbf{z}^{(k)}$ ;

$$\mathbf{D}^{(k)} = -\text{diag} \left( \frac{s_i}{\dot{x}_i \dot{x}_i^{(k)}} \right)$$

## Result and Discussions

The convergence of the created iterative process is ensured by the following theorem:

**Theorem:** The inverse matrix method defined by the formula

$$\mathbf{z}^{(k+1)} := \mathbf{A}^{-1} \mathbf{D}^{(k)} \dot{\mathbf{z}}^{(k)} \quad (5)$$

for problem (2) with an arbitrary initial interval  $\mathbf{z}^{(0)} \in \mathbf{IC}$  converges to a single fixed point  $\mathbf{z}^*$  if and only if  $\rho(|\mathbf{A}^{-1} \mathbf{D}|) < 1$ .

In proving this theorem, we depend on the Schroeder fixed-point theorem, employing the contraction operator for the interval map  $f: \mathbf{IC}^n \rightarrow \mathbf{IC}^n$  [2].

**Proof. Sufficiency.** Consider the map  $f: \mathbf{IC}^n \rightarrow \mathbf{IC}^n$  by the formula  $f(\mathbf{z}) = \mathbf{A}^{-1} \mathbf{D} \dot{\mathbf{z}}$ . Let  $\mathbf{x}, \mathbf{y} \in \mathbf{IC}^n$ . Applying  $\text{dist}(\mathbf{x}, \mathbf{y}) = \text{dist}(\dot{\mathbf{x}}, \dot{\mathbf{y}})$  also from the relations given in Proposition 1, we obtain  $\mathbf{z}^{(k+1)} = \mathbf{A}^{-1} \mathbf{D}^{(k)} \dot{\mathbf{z}}^{(k)}$ ,  $k = 0, 1, 2, \dots$  (6) converge for each  $\mathbf{z}^0 \in \mathbf{IC}^n$  to a fixed point  $\mathbf{z}^*$ . We show that  $\rho(|\mathbf{A}^{-1} \mathbf{D}^{(k)}|) < 1$ .

According to the Perron-Frobenius theorem [11], a non-negative square matrix possesses a non-negative eigenvector that corresponds to the largest non-negative eigenvalue in magnitude  $\lambda = \rho(|\mathbf{A}|)$ . From the convergence of the approximations (12) to  $z^*$  for any initial vector  $z^0$  it follows that the sequence  $\{wid z^{(k)}\}_{k=0}^{\infty}$  converges to  $wid z^*$ . We now choose  $z^0$ , as an initial approximation for the iterative process (6), so that  $wid z^0$  is an eigenvector corresponding to the  $\lambda = \rho(|\mathbf{A}^{-1}\mathbf{D}|)$  matrix  $|\mathbf{B}| + |\mathbf{D}_1|$ , and at least one component of the fast vector  $wid z^0$  is larger than the corresponding component of the  $wid z^*$ . Then assuming  $\lambda \geq 1$  and  $wid z = wid \dot{z}$ , we can conclude that

$$\begin{aligned} wid z^{(1)} &= wid (\mathbf{B}z^{(0)}) + wid (\mathbf{D}_1^{(0)} \dot{z}^{(0)}) \geq |\mathbf{B}|wid z^0 + |\mathbf{D}_1^{(0)}|wid \dot{z}^{(0)} = \\ &= (|\mathbf{B}| + |\mathbf{D}_1^{(0)}|)wid z^{(0)} = \lambda wid z^{(0)} \geq wid z^{(0)}. \end{aligned}$$

$$\begin{aligned} \text{Similarly } wid z^{(2)} &\geq (|\mathbf{B}| + |\mathbf{D}_1^{(1)}|)wid z^1 \geq (|\mathbf{B}| + |\mathbf{D}_1^{(1)}|)\lambda wid z^0 = \\ &\lambda^2 wid z^{(0)} \geq wid z^0, \text{ etc.} \end{aligned}$$

Now for arbitrary  $k$  we have

$$wid z^{(k)} \geq (|\mathbf{B}| + |\mathbf{D}_1^{(k-1)}|)wid z^{k-1} \geq \dots \geq \lambda^k wid z^0 \geq \lambda^k wid z^{(0)} \geq wid z^0.$$

Passing to the limit at  $k \rightarrow \infty$ , we obtain

$$wid z^* \geq wid z^{(0)} \quad [3]$$

Which contradicts our choice of the initial vector  $z^{(0)}$ . Therefore, our assumption  $\lambda \geq 1$  is incorrect, i.e.  $\rho(|\mathbf{A}^{-1}\mathbf{D}_2^{(k)}|) < 1$ , as required to prove. [4]

## Conclusions

The findings outlined in the article enable an examination of the iterative approximation process and offer insights into methods to expedite convergence. Subsequent experiments are conducted to determine the optimal acceleration coefficients. Utilizing these coefficients in the calculation method significantly reduces the number of iterations, resulting in narrower outer estimates of solution sets.

## References:

- [1] Fazylov H.F., Nasyrov T.Kh., "The established modes of electric power systems and their optimization", - Tashkent: *Molia*, 1999.
- [2] Ibragimov A.A., "Interval-iterative methods for solving the nodal equations of steady state modes of electric networks", - *Vestnik: NUUZ*, 2010, No. 3, pp. 87-91.
- [3] Kolev L.V., "Interval methods for circuit analysis", - Singapore, New Jersey, London, Hong-Kong: *World Scientific*, 1993.
- [4] Barboza L.V., Dimuro G.P., Reiser R.H.S., "Interval Mathematics Applied to the Load Flow Analysis", *Proceeding of the 17-th IMACS World Congress*



- Scientific Computation, Applied Mathematics and Simulation*, Paris, France, 2005.
- [5] Kearfott R.B., Nakao M.T., Neumaier A., Rump S.M., Shary S.P., Hentenryck P., “Standardized notation in interval analysis”, *Computational technologies*, Vol. 15, No. 1, 2010, pp. 7–13. <http://www.ict.nsc.ru/interval/InteNotation.ps>.
- [6] Ibragimov, A.A., Bazarov, M.B., Shokin, Yu.I., Yuldashev, Z.Kh., “Mathematical modeling by interval methods”, -Tashkent: *Publishing house “Fan”*, 2013, p.160.
- [7] Ibragimov A.A., Tokhirov F.J., “Method inverse Matrix for Calculation Stable Electrical Systems Modes under Interval Data Uncertainty”, *Test engineering and management*, ISSN: 0193-4120. March-April, 2020. pp. 24327-24331.
- [8] Hertz D., “Interval analysis: eigenvalue bounds of interval matrices” in C.A. Floudas, P.M. Pardalos (Eds.), *Encyclopedia of Optimization*, Springer, New York, 2009. –pp.1689-1696.
- [9] Ibragimov A.A., Khamroeva D.N., “Iterative algorithms for solving the partial eigenvalue problem for symmetric interval matrixes”, *Mathematics and Statistics*, № 6(10), 2022, № 6(10), pp. 1229-1238.
- [10] Ibragimov A.A., Khamroeva D.N., “On analysis of the computing process with interval data”, *Problems of Computational and Applied Mathematics*, - № 2(32): 2021, pp. 38-48.
- [11] Alefeld G., Herzberger Yu., “Introduction to interval calculations”, - Moscow: *Mir*, 1987.
- [12] Shary S.P., “Finite-dimensional interval analysis”, -E-book, see: <http://www.nsc.ru/interval/Library/InteBooks>.



UDC: 553.3/9,661,661.3

## MODELING AND OPTIMIZATION OF THE TECHNOLOGICAL PROCESS OF FLOTATION OF POTASSIUM ORES

**Isakov Abror Fakhriddinovich**

*Deputy head at the department  
Information Technologies of the  
Academy of the Ministry of  
Internal Affairs*

[aisaqov921@gmail.com](mailto:aisaqov921@gmail.com)

**Nasirova Shaira Narmuradovna**

*Professor at the Department of  
Computer Science, Navoiy State  
Pedagogical Institute,*

[nasirova\\_61@mail.ru](mailto:nasirova_61@mail.ru)

**Annotatsiya.** Maqolada kaliy rudalarini flotatsiya qilishning texnologik jarayonini modellashtirish va optimallashtirish muhokama qilinadi. Kaliyli o'g'itlar ishlab chiqarishda eng muhim jarayonlardan biri flotatsiya jarayoni bo'lib, yakuniy mahsulot sifatini belgilaydi. Flotatsiyani boyitish jarayonining samaradorligi ko'p sonli omillarga bog'liq bo'lib, jarayonni tavsiflash uchun modellarni murakkablashtiradi va flotatsiyani boshqarish hamda optimallashtirishning murakkabligini oldindan belgilaydi.

**Kalit so'zlar:** modellashtirish, optimallashtirish, jarayon, flotatsiya, kaliy, ruda, omil, boshqarish.

**Аннотация.** В статье рассматриваются моделирование и оптимизация технологического процесса флотации калийных руд. Одним из важнейших процессов при производстве калийных удобрений является процесс флотации, который определяет качество конечного продукта. Эффективность процесса флотационного обогащения зависит от большого количества факторов, что усложняет модели описания процесса и предопределяет сложность управления и оптимизации флотации.

**Ключевые слова:** моделирование, оптимизация, процесс, флотация, калий, руда, фактор, управления.

**Abstract.** The article discusses the modeling and optimization of the technological process of flotation of potash ores. One of the most important processes in the production of potash fertilizers is the flotation process, which determines the quality of the final product. The efficiency of the flotation enrichment process depends on a large number of factors, which complicates models for describing the process and predetermines the complexity of flotation management and optimization.

**Keywords:** modeling, optimization, process, flotation, potassium, ore, factor, control.

## Introduction

Scientific research in the field of processing industry in the world made it possible to improve the quality of the product and reduce energy consumption due to the wide use of modern technologies in the modeling and optimization of technological processes in the production of highly efficient, reliable and cost-effective technological devices in the modern conditions of work.

Over the past century, there has been a sharp activation of the development of underground resources by mankind, which is manifested by an increase in the volume of extraction of minerals. Mining and beneficiation is characterized by the extraction and processing of large rocks.

Flotation is a method of mineral enrichment based on the use of differences in the physical and chemical properties of the surface of finely ground particles of separated minerals suspended in an aqueous environment, expressed in the selective adhesion of particles to the surface of air bubbles [1].

## Literature Review

The growth of economic indicators of ore processing enterprises and further improvement of their work necessarily depend on the objectives of the processes and the development of a method for assessing the implementation of established plans. In the article it is shown that all stages of studying the choice of performance assessment: availability of information, optimization method, choice of decision and its adoption, result. For separation processes, incl. flotation, the difficulty of choosing an efficiency criterion is complicated by the fact that such processes are assessed by several indicators. Thus, the assessment of the flotation process of potassium chloride must be carried out taking into account not only the amount of the main reagent in the concentrate, but also its loss with waste, the presence of harmful impurities in the concentrate, etc. In this regard, to fully assess the efficiency of flotation, it is necessary to use several different criteria, but this creates great difficulties in carrying out technological processes and studying them. There is no single criterion because there are different ways to create an optimal operating process for a flotation enterprise, and there are no general approaches to performing tasks based on generally accepted assumptions [2].

Under the influence of the chemical composition of raw materials, the properties of the liquid phase of the suspension, the ratio of component costs, the performance of technological devices, etc. etc. During the enrichment process, physicochemical conditions are formed. Previously, the aspiration of the flotator was noted to optimize the main parameters or foam in the flotator, the physico-chemical properties of the pulp. The impact of a large number of parameters on the flotation process and the lack of data on fluctuations in parameters lead to the fact that the main role in the influence of parameters on flotation management is played by personal experience and work experience. This became the basis for S.G. Bushel to call the management of the reagent regime for the enrichment of natural ore. More art than science. This is exactly what I.N. claimed Plaksin, who pointed out that the theoretical foundations of flotation

use not qualitative, but quantitative characteristics, and flotation regulation is carried out mainly empirically [3].

### **Research Methodology**

In recent years, the situation has begun to change due to improvements in flotation theory and the development of systems for optimal flotation processes. The use of computer technology required the creation of a formalized description of the objects of the flotation process, operating with specific mathematical relationships, as well as methods for optimization by multifactor processes. Technologies at enterprises are characterized by complex schemes, a large number of interdependent indicators, and the presence of uncontrolled external manifestations that change randomly. This proves the well-known opinion that, with the same process parameters, there are different results of knowledge about flotation in order to, when applied, create an analytical model of flotation that can be accurately calculated. [4] considers the reasons why an analytical description of enrichment processes is impossible, in connection with this, these processes are more often analyzed as probabilistic, the theories of probability and mathematical statistics are used to study them, enrichment processes do not often occur as probabilistic ones. For a specific process, there is always an analytical part used to create its mathematical model. Many complex technological processes cannot be described analytically, which includes flotation. To obtain the data needed to implement an optimal flotation process. Such processes are usually studied by empirically finding dependencies between input and output parameters, without taking into account the internal composition of the latter [4].

The mathematical model of the flotation process is in the form of developed mathematical expressions. The mathematical model makes it possible, using certain algorithms, to know the progress of the process when conditions change and can be used to perform various tasks of research and optimization of industrial flotation of various natural ores. It is necessary to know that, within the limits of the problem being solved, the model accurately demonstrates the properties of the model object, i.e. was adequate. In practice, you usually have to work with models that inaccurately describe the properties of the object being studied. Currently, more and more works are appearing devoted to the analytical study of this process. Among these works, we can note those carried out on thermodynamic analysis of the mutual dependence of reagents [5].

Research and optimization of the flotation process is being improved in three areas: modeling phenomena on the surface and creating a reagent regime, creating hydrodynamics of the modeling process and optimizing the flotation process of natural ores. These works, one might say, are not interrelated. Future research is expected to explore some aspects of the second direction. Thus, optimization of the structure of flows in the foam layer is a significant reserve for improving the performance of the flotation process of potassium fertilizer [6].

Tikhonov O.N., and others created a model that does not take into account the dependence of the flotation process on the composition of the flows and is dependent on disturbances; the positive aspects of this model that greatly reduce the scope of its



use are the clarity and ease of use in calculations and optimization of flotation, but for the study of hydrodynamics the process and development of the fundamentals of the method require in-depth research physical and mechanical indicators of flotation. With an increase in flotation time and a decrease in the degree of aeration of the suspension, the results of flotation do not change, which contradicts the test results [8].

At this stage, the use of modeling methods and optimization makes it possible to determine the optimal technological parameters of the flotation process of natural sylvinitic ore and the technological scheme for separating the bio-suspension. All technological processes for increasing the concentration of microorganism pulps are given in publications [8].

The choice of solution method and calculation algorithm is made upon completion of the mathematical description and finding the corresponding boundary parameters. Taking this into account, based on the Navier-Stokes control, we can conclude that the calculations under study made it possible to identify the main patterns of media flow near bodies (boundary layer theory) and at the periphery of the flow. But implementation requires detailed knowledge in the field of calculations, and this is due to the complexity and nonlinearity of the original equations. In this regard, the main way to solve problems is the numerical method. The complexity of calculations when solving the problems under study increases rapidly with the increase in the number of independent variables [9-10].

A rational way to solve the equations of continuum dynamics is, of course, the difference method. The use of this method makes it possible to solve many classes of hydrodynamics problems, including numerical descriptions of rupture zones of contact surfaces of transition zones and other specific flow characteristics [11-12].

## Analysis and Results

When carrying out calculations, it is necessary to take into account that modern design and calculation of equipment for flotation and natural ores dictates the study of their density and viscosity, which makes it possible to solve problems of the flow of these media in various parts of the equipment and, ultimately, calculate their production indicators. Taking into account the design features of the equipment and the conditions of the technological process, the following properties of the processed raw material may appear at different levels: viscosity deviation, surface slip (l-effect), stress relaxation, viscoelastic effects, etc.

## Conclusions

These indicators are identified empirically and are present in the mathematical description of the object, which once again proves about the impossibility of creating only theoretically, i.e. There are indicators that are found empirically. The adequacy of the mathematical model to the current process is also determined empirically. Here, a joint structural and empirical approach to preparing a mathematical model is revealed.

## References:

- [1] Rubinstein Yu. B., Filippov Yu. A., "Kinetics of flotation", M.: Nedra, 1980, p. 375.



- [2] Isakov A.F., Artikov A.A., Nasirova Sh.N., “Systems thinking in flotation apparatus management”, *Scientific journal UNIVERSUM: Technical Sciences*, No. 7 (76), July, 2020 Russia, pp. 52-56.
- [3] Soroker L.V., “Development of effective methods for research and automated control of flotation complexes in non-ferrous metallurgy”, *North Caucasus mountains -metallurgist*, Institute - Vladikavkaz, 2004, p. 384.
- [4] Artikov A.A., Nasirova Sh.N., Isakov A.F., “Systems thinking in the analysis of a flotation apparatus and modeling of ore processing processes”, Monograph. – Tashkent: *Fan*, 2022, p. 159.
- [5] Nasirova Sh.N., “Analytical method of Identification of an Object Automation on examples of Flotation of ores of Precious Metals”, *International Journal of Scientific & Engineering Research*, Volume 8, Issue 2, February-2017, ISSN 2229-5518, pp. 822-826.
- [6] Zhang, W., “Frothers and frother blends: a structure – function study”, *A thesis submitted to the Faculty of Graduate Studies and Research in partial fulfillment of the requirements of the degree of PhD: – McGill University*. Montreal, Canada, 2012, p. 150.
- [7] Nasirova S.N., Artikov A.A., Isakov A.F., Mirzakulov K.C., “Reasoning system in analysis of bubbling zone of flotation, on the example of potash ore enrichment”, *Journal of advanced research in dynamical & control systems*, vol. 12, special issue-06, 2020, pp. 558-565. DOI: 10.5373/JARDCS/V12SP6/SP20201063.
- [8] Tikhonov A. N., Arsenin V. Ya., “Methods of solving incorrect problems”, M.: *Nauka*, The main edition of physical and mathematical literature, 1979. 2<sup>nd</sup> edition.
- [9] Badenkov V.Ya., “Physico-chemical and technological foundations of plasma processing of low-grade mineral raw materials”, 2001, p. 157. <https://www.dissercat.com/content/fiziko-khimicheskie-i-tehnologicheskie-osnovy-plazmennoi-obrabotki-nizkosortnogo-mineralnog>
- [10] Morozov V. V., Topchaev V. P., Ulitenko K. Ya., Ganbaatar Z., Delgerbat L., “Development and application of automated control systems for mineral processing processes” Published by: Publishing House “*Ore and Metals*” 2013, p. 512.
- [11] Afonin V.V., “Modeling systems: Educational and practical guide” / V.V. Afonin, S.A. Fedosin. – M.: *Internet University of Information Technologies*; BINOMIAL. Knowledge Laboratory, 2010, p. 231.
- [12] Dvoretzky S.I., Muromtsev Yu.L., Pogonin V.A., “Systems modeling”, - M.: Publishing house. Center “*Academy*”, 2009, p. 320.



## MODERN PROBLEMS OF TECHNICAL SCIENCES

UDC: 004,004.23,004.67

### AUTOMATED SYSTEM FOR ASSESSING THE QUALIFICATIONS OF EMPLOYEES IN IT DEPARTMENTS

**Medetova Kunduz Muratovna**

*Senior lecturer at the Department of  
Information systems and technologies  
Tashkent State University of Economics*

[k.medetova@tsue.uz](mailto:k.medetova@tsue.uz)

**Annotatsiya.** Raqamlashtirish va doimiy texnologik taraqqiyot davrida kadrlar bilan ishlash jarayonlarini avtomatlashtirishga, xususan, AT bo'limlari mutaxassislarining malakasini har tomonlama baholashga alohida e'tibor qaratilmoqda. Ushbu maqola nafaqat nomzodlar va AT bo'limi xodimlarining texnik ko'nikmalari va kasbiy bilimlarini samarali baholash, balki ularning kelgusida rivojlanish va jamoaga integratsiyalashuv potentsialini bashorat qilish imkonini beruvchi kompleks malakaviy baholashning avtomatlashtirilgan tizimini tahlil qilishga bag'ishlangan. Tadqiqot tizimning asosiy funktsional jihatlariga, jumladan nomzodlar ma'lumotlarini tahlil qilish uchun mashinani o'rganish usullariga, ish talablariga ko'nikmalarni moslashtirish algoritmlariga va texnik intervyu va test vositalariga qaratilgan. Tizimni tashkilotning mavjud kadrlar infratuzilmasi bilan integratsiyalash va uni AT bo'limi ish jarayonlarining o'ziga xos xususiyatlariga moslashtirish imkoniyatlariga alohida e'tibor qaratilgan. To'plangan ma'lumotlarni tahlil qilish asosida maqolada AT-mutaxassislarini tanlash va rivojlantirish samaradorligini oshirish uchun avtomatlashtirilgan kompleks baholash tizimlarining ahamiyati to'g'risida xulosalar, shuningdek ularni joriy etish va optimallashtirish bo'yicha tavsiyalar keltirilgan. Tadqiqot shuni ta'kidlaydiki, bunday tizimlardan foydalanish AT-sanoatda ishga qabul qilish va martaba qarorlarini qabul qilish sifatini sezilarli darajada yaxshilaydi, yuqori malakali va muvofiqlashtirilgan jamoalarni shakllantirishga yordam beradi.

**Kalit so'zlar:** Avtomatlashtirilgan baholash tizimi, IT-mutaxassislarining malakasi, kadrlar bo'yicha mashinalarni o'rgatish, nomzodlarni kompleks baholash, xodimlarni ishga qabul qilish texnologiyalari, HR jarayonlarini optimallashtirish, nomzodlar ma'lumotlarini tahlil qilish, HR tizimlari integratsiyasi, IT-guruhlarini rivojlantirish, ishga olish samaradorligi.

**Аннотация.** В эпоху цифровизации и постоянного технологического прогресса, особое внимание уделяется автоматизации HR-процессов, в частности, комплексной оценки квалификации специалистов в IT отделах. Данная статья посвящена анализу автоматизированной системы комплексной оценки квалификации, которая позволяет не только эффективно оценивать технические навыки и профессиональные знания

кандидатов и сотрудников ИТ отдела, но также прогнозировать их потенциал для дальнейшего развития и интеграции в команду. Исследование фокусируется на основных функциональных аспектах системы, включая методы машинного обучения для анализа данных о кандидатах, алгоритмы сопоставления навыков с требованиями вакансий, а также инструменты для проведения технических интервью и тестирования. Особое внимание уделено вопросам интеграции системы с существующей HR-инфраструктурой организации и возможностям её адаптации под специфику рабочих процессов ИТ отдела. На основе анализа собранных данных, в статье представлены выводы о значимости автоматизированных систем комплексной оценки для повышения эффективности подбора и развития ИТ специалистов, а также рекомендации по их внедрению и оптимизации. Исследование подчеркивает, что применение таких систем может существенно повышать качество решений по найму и карьерному продвижению в ИТ сфере, способствуя формированию высококвалифицированных и согласованных команд.

**Ключевые слова:** Автоматизированная система оценки, квалификация ИТ специалистов, машинное обучение в HR, комплексная оценка кандидатов, технологии подбора персонала, оптимизация HR-процессов, анализ данных о кандидатах, интеграция HR-систем, развитие ИТ команд, эффективность найма.

**Abstract.** In the era of digitalization and constant technological progress, special attention is paid to the automation of HR processes, in particular, a comprehensive assessment of the qualifications of specialists in IT departments. This article is devoted to the analysis of an automated system for comprehensive qualification assessment, which allows not only to effectively assess the technical skills and professional knowledge of candidates and IT department employees, but also to predict their potential for further development and integration into the team. The research focuses on key functional aspects of the system, including machine learning techniques for analyzing candidate data, algorithms for matching skills to job requirements, and tools for technical interviewing and testing. Particular attention is paid to the issues of integrating the system with the existing HR infrastructure of the organization and the possibilities of its adaptation to the specifics of the work processes of the IT department. Based on the analysis of the collected data, the article presents conclusions about the importance of automated comprehensive assessment systems for increasing the efficiency of the selection and development of IT specialists, as well as recommendations for their implementation and optimization. The study highlights that the use of such systems can significantly improve the quality of hiring and career decisions in the IT industry, helping to build highly skilled and aligned teams.

**Keywords:** Automated assessment system, qualification of IT specialists, machine learning in HR, comprehensive assessment of candidates, personnel



selection technologies, optimization of HR processes, analysis of candidate data, integration of HR systems, development of IT teams, hiring efficiency.

## **Introduction**

In the modern world, the importance of technology in the process of personnel selection and assessment is steadily growing, especially in the field of information technology, where the requirements for the qualifications of specialists are constantly increasing. Automated qualification assessment systems are becoming a key tool for HR professionals seeking to optimize talent selection and development processes. These systems offer an integrated approach to assessing potential and current employees, allowing not only to significantly reduce the time spent analyzing resumes and conducting interviews, but also to increase the objectivity and accuracy of assessments.

The use of automated assessment systems in IT departments opens up new prospects for identifying and developing highly qualified specialists who meet the current and future needs of the company. The use of machine learning and artificial intelligence algorithms in these systems allows you to analyze large amounts of candidate data, identifying the most suitable in terms of technical skills, professional experience and fit with corporate culture. Thus, automation of qualification assessment processes opens up new opportunities for increasing the efficiency of human resource management in the IT sector, contributing to the formation of competitive and innovative teams.

## **Literature Review**

Currently, many solutions have been carried out and developed in this area. In particular, a study of the use of machine learning to automate personnel selection was conducted by the authors [1,2] about how machine learning algorithms can improve the personnel selection process, making it faster and more accurate. The development and implementation of integrated talent management systems are given in works [3,4] as a tool for promoting effective human resource management in IT and other industries. Works [5,6] provide examples of the use of artificial intelligence in recruiting personnel. Many articles by the authors [7,9] emphasize the importance of artificial intelligence in automating the processes of selection and assessment of candidates, especially in the IT field. Assessing Candidate Culture Fit: The authors' study [8] focuses on how automated systems can assess candidate culture fit, a key aspect of successful employee integration. Improving the quality of hiring through automation is shown in research [6] on how automated assessment systems can improve the quality of hiring by reducing the number of erroneous decisions and improving the match between job requirements and candidate qualifications. Various aspects in the field of knowledge assessment, creation and application of training systems based on modern information technologies, issues of developing databases and knowledge bases of software systems were considered by the following domestic and foreign scientists.

## Research Methodology

The goal of creating an automated system for comprehensive assessment of the qualifications of IT department specialists is to maximize the efficiency and objectivity of the personnel selection and development process by integrating modern technologies for data analysis and machine learning. The system is designed to provide HR professionals with a powerful tool for in-depth analysis of candidate skills, experience and potential, facilitating quick and accurate matching of candidates with job requirements and corporate culture. It aims to reduce the time and resources spent on selection processes, while improving the quality of hiring and helping to build high-performing teams that can effectively implement technological innovations and support the dynamic development of organizations in the digital age.

An automated system for comprehensive assessment of the qualifications of IT department specialists will allow solving a number of important tasks, see Fig. 1:

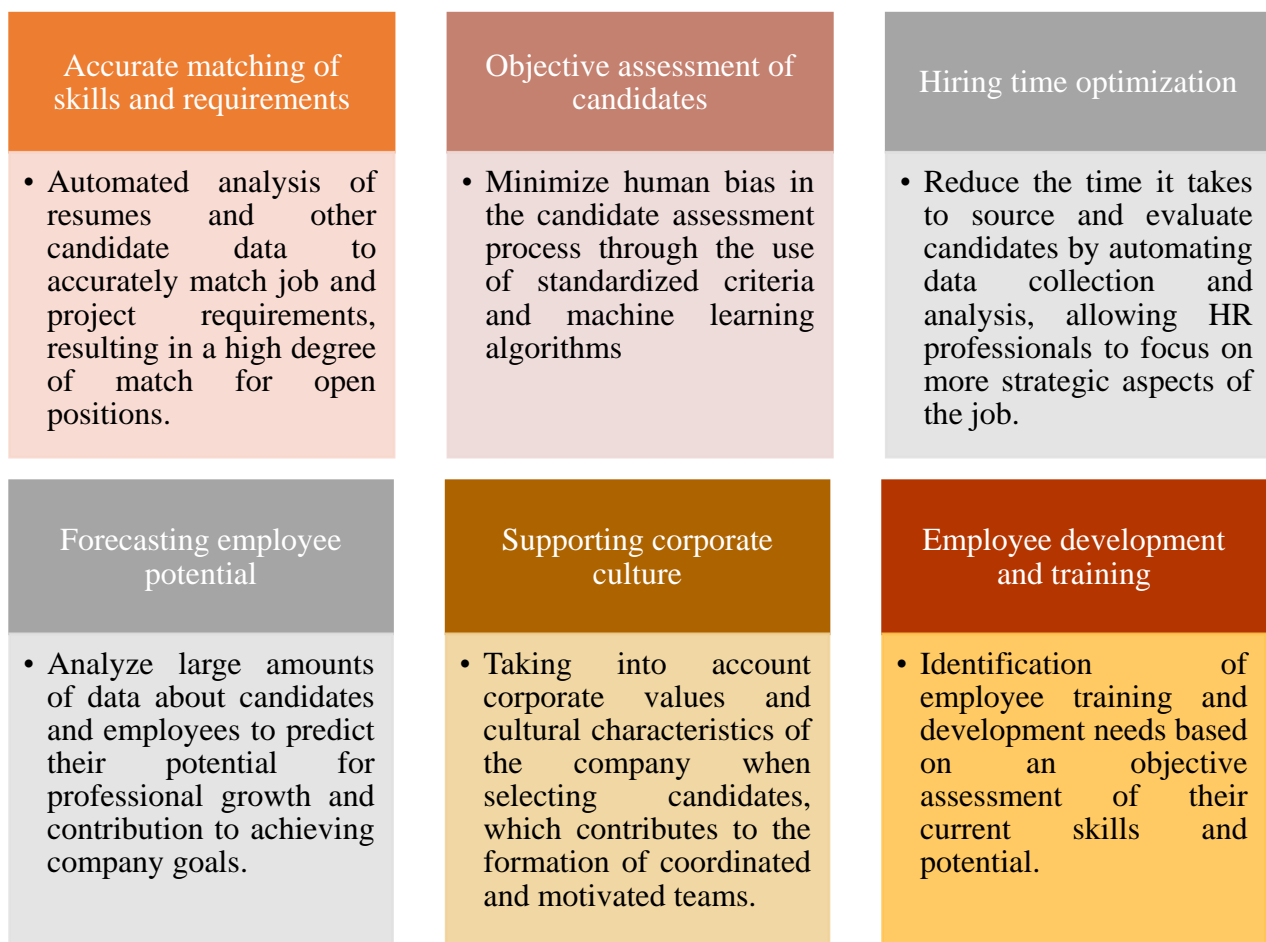

**Figure 1.** Problems solved by the AS for qualification assessment.

Thus, this system is a comprehensive tool that allows not only to effectively evaluate and select candidates, but also contributes to their further development and integration into the team, as well as the maintenance and development of corporate culture.

When developing an automated system for assessing the qualifications of IT specialists, it is necessary to pay special attention to the structure of the system, operating algorithms, and assessment methods used [4]. In order to assess how these

tasks are solved in other automated systems for selecting and assessing personnel knowledge present on the international market, a brief review and analysis of them was carried out, see Table 1. In total, as a result of the research within the framework of this article, 9 automated knowledge assessment systems were studied, using testing, game methods, practical tasks and others as a method of assessing knowledge. The presented automated assessment and knowledge control systems allow solving problems of managing adaptive tests (creating, editing and deleting tests) and conducting testing for IT specialists, but they have different functionality in solving these problems, which ultimately affects the quality of assessment results [12].

**Table 1.** Review of automated personnel assessment systems.

| <b>№</b> | <b>System</b>             | <b>Features</b>   | <b>Application</b>   |
|----------|---------------------------|---|--|
| 1.       | LinkedIn Talent Solutions | A set of tools for searching and assessing candidates through a professional network.   | Search for candidates with the required skills, publish vacancies, analyze activity.           |
| 2.       | HireVue                   | Video interviews and cognitive games that use machine learning algorithms to evaluate candidates.   | Assessing candidates' social and cognitive abilities.  |
| 3.       | HackerRank                | A platform for evaluating programmers through coding tasks.   | Technical testing of candidates for programming positions.                                     |
| 4.       | Devskiller                | Platform for automated testing of programming, web development and data analysis skills.  | Assessment of technical skills in IT and programming.  |
| 5.       | Testgorilla               | Offers a wide range of psychometric, cognitive and technical tests to assess candidates.  | Assess a wide range of skills from technical to soft skills.                                   |
| 6.       | Codility                  | A technical testing platform that helps evaluate candidates' programming skills through coding tests and challenges.                          | Technical assessment of candidates for positions in software development.                      |
| 7.       | HeadHunter Assessment     | A module on hh.ru that allows you to create and conduct online testing of candidates for various skills and competencies                      | Assessment of professional skills and competencies of candidates in various fields.            |
| 8.       | Skillbox Assessments      | Online courses and assessments designed to assess and improve professional skills in IT, design, marketing and management.                    | Preliminary assessment and development of skills of specialists in the creative and IT fields. |
| 9.       | My Circle Tests           | A service from the social network My Circle, which allows online testing of IT specialists in various technologies and programming languages. | Assessing the technical skills of IT specialists.  |

The functional differences between professional assessment systems are due to their unique approaches to assessing skills, use of technology, and purpose. For example, platforms such as HireVue and Pymetrics emphasize the use of video interviews and game mechanics to assess candidates' cognitive abilities and personality traits. These tools use machine learning algorithms and elements of neuroscience to not only assess professional skills, but also predict how well a candidate will fit into the corporate

culture and team [10]. This approach emphasizes the soft skills and adaptability that are critical to succeeding in today's fast-paced work environment.

At the same time, systems such as HackerRank and Codility focus on technical testing of candidates. They offer comprehensive programming and data analysis challenges that help assess the specific skills needed to work in the IT sector. These platforms are ideal for assessing candidates' professional level, their ability to solve complex problems and their readiness to quickly learn new technologies. They provide HR professionals and department managers with detailed test results reports, which is key to making an informed and effective selection of the best candidates.

Modules on platforms such as HeadHunter Assessment and My Circle Tests complement these approaches by offering assessment tools designed specifically for the CIS labor market [11]. They take into account local characteristics and requirements for specialist qualifications, providing companies with tools for assessing a wide range of professional skills and competencies. This allows not only to effectively assess the technical skills of candidates, but also their compliance with the specific requirements of the labor market in the CIS countries.

Thus, the choice of a qualification assessment system depends on the specific hiring goals, the specifics of the vacancy and the key requirements for the candidate. It is important to choose a tool that best suits the needs of the organization and allows you to comprehensively assess the potential of applicants.

## **Analysis and Results**

One of the disadvantages of the above automated qualification assessment systems is their excessive dependence on test questions as the main assessment tool. Although tests can be an effective means of testing specific knowledge and skills, they do not always adequately reflect the full range of competencies required for successful performance. In particular, test questions may not take into account the candidate's ability to think critically, solve complex and non-routine problems, as well as to interact effectively in a team and adapt to changing work conditions.

Additionally, test items may be limited in their ability to assess candidates' creativity and innovation, which are increasingly valuable in today's dynamic and rapidly changing business landscape. This is especially true in the IT sector and other areas where the ability to innovate and creative problem solving are key factors for success.

In this regard, it is important for organizations to take a comprehensive approach to competency assessment, which includes not only testing, but also other assessment methods such as project work, case methods, work simulations and interactive tasks. This will allow a more complete and objective assessment of the candidate's potential and his ability to contribute to the success of the company. Incorporating a variety of assessment methods not only helps in more accurate selection of candidates, but also provides them with the opportunity to demonstrate their strengths in a variety of situations, which ultimately helps in finding the most suitable employee for a specific role in the organization.



The article suggests several methods that can be included in an assessment system to provide an integrated approach:

1. Coding tests and technical assignments: Assess a candidate's ability to solve real-life programming and development problems. Such tests can range from simple algorithmic problems to complex design work that requires knowledge in a particular area of development.

2. Project portfolio: Analysis of projects the candidate has already completed, including source code, documentation and user reviews. The portfolio gives an idea of the candidate's practical experience, his role in projects and the results achieved.

3. Simulations of work situations and case methods: Simulation of real business situations that require the candidate to make decisions based on data analysis, planning and project management. These simulations help assess analytical skills, strategic thinking and teamwork.

4. Live technical problem-solving interview: A dialogue with the candidate during which he must solve one or more technical problems, demonstrating his approaches and thinking. This allows you to not only evaluate technical skills, but also see the candidate's thinking process.

5. Psychometric testing: Uses standardized psychometric tests to assess personality, motivation, stress tolerance, and other soft skills important for successful teamwork and adaptation to corporate culture.

6. Feedback from previous employers and teams: Gathering references and feedback from a candidate's previous colleagues and supervisors can provide valuable insight into a candidate's professional behavior, teamwork, and contributions to projects.

So, for the automated comprehensive qualification assessment system, the following methods were selected and justified: coding tests and technical assignments, project portfolios, simulations of work situations and case methods, interviews with real-time solutions to technical problems, psychological testing and feedback from previous employers and teams.

The main modules of the automated qualification assessment system are the HR department module, the system manager module, the candidate who has passed the initial selection, and the enterprise specialist.

- Data collection module - collects all information about the candidate, including resume, motivation letters, portfolio, test results and recommendations.

- Data Analysis Module - uses algorithms to analyze collected data and identify key qualifications and skills of candidates.

- Skills Assessment Module - evaluates candidates' hard and soft skills based on data analysis and test results.

- Testing module - manages specialized tests to assess the knowledge and skills of candidates.

- Comparison module - compares candidate profiles with job requirements, creates a ranking of candidates.

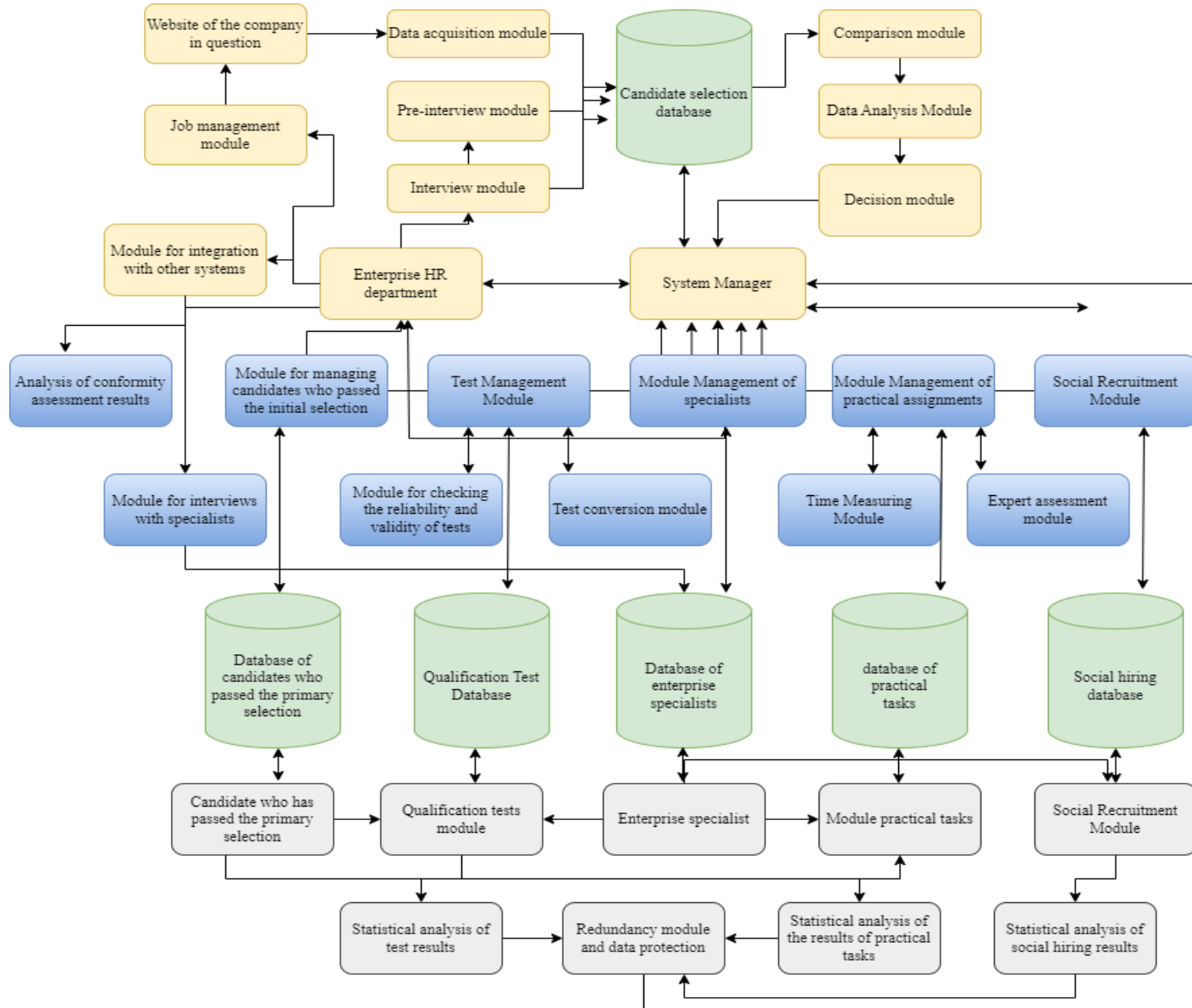

**Figure 2.** Functional diagram of an automated qualification assessment system.



- Decision module - analyzes data to make decisions about candidate suitability for a job opening using AI and machine learning.
- Reporting module - generates reports on candidate assessment, qualifications, rankings and recommendations.
- User Interface - Provides an interface for interacting with the system, setting assessment parameters and viewing results.
- Recruitment Planning Module - Helps plan recruitment needs based on the current and future needs of the organization.
- Job vacancy management module - allows you to create and manage vacancies, publish them on the corporate website or external platforms.
- Applicant Management Module - provides tools for managing candidates at various stages of selection, from application to hiring.
- Feedback module - automates the process of collecting and analyzing feedback from candidates and interviewers to improve the selection process.
- Integration module with HR systems - provides integration with other HR systems and databases for exchanging information about candidates and employees.
- Social Recruiting Module - uses social networks and professional platforms to find and attract candidates.
- Analytics and Reporting Module - Provides advanced analytical tools and reports to evaluate the effectiveness of hiring processes and identify trends.

## Conclusions

As a result of the analysis of existing systems for assessing the qualifications of specialists in IT departments, we developed the concept of an automated comprehensive assessment system. Our system is an innovative approach to assessing employee qualifications, which allows you to effectively identify and develop the key competencies of IT specialists.

- Creation of a universal platform for assessing the competencies of specialists in the IT department.
- Increasing the efficiency of the process of assessing qualifications and selecting candidates for vacancies.
- Improving the training and development of employees in accordance with the needs of the company.
- Increasing the level of staff qualifications and overall productivity of the IT department.
- The ability to integrate existing assessment methods and adapt the system to the specific needs of the organization.

These results confirm the importance and significance of our work in the development and implementation of an automated system for comprehensive assessment of the qualifications of specialists in the IT department.

## References:

- [1] O'Neill T.R., Peabody M.R., Stelter K.L., Puffer J.C., Brady J.E., "Validating the test plan specifications for the American Board of Family Medicine's Certification Examination", *J. Am. Board Fam Med.* 32(6), 2019, pp. 876-882.



- [2] Galeev I.Kh., “Computer control of knowledge” (locally and remotely) / Galeev I.Kh., Ivanov V.G., Khramov D.L., Kolosov O.V., edited by THEIR. Galeva. - Kazan: *Kazan State Technological University*, 2005, p. 126.
- [3] Marisheva L.T., Medetova K.M., “Methods for determining the level of staff turnover in an organization”, *Central Asian Journal Of Education And Computer Sciences (CAJECS)* 1 (2), pp. 17-20.
- [4] Ivanov M.V., “Automated system for comprehensive assessment of the qualifications of printing production specialists”, *Vestnik MGUP*, №8, 2011. <https://cyberleninka.ru/article/n/avtomatizirovannaya-sistema-kompleksnoy-otsenki-kvalifikatsii-spetsialistov-poligraficheskogo-proizvodstva>
- [5] Musaeva A.Z., Rasulova R.M., “Introduction of an automated system for personnel assessment in an organization”, *Issues of structuring the economy*, №1, 2010. <https://cyberleninka.ru/article/n/vnedrenie-avtomatizirovannoy-sistemy-otsenki-personala-v-organizatsii>.
- [6] Mirzoyan M.V., Solyanov K.S., “Developing the information system for monitoring and analyzing the efficiency of human capital in the civil service system”, *Vestnik Altayskoy akademii ekonomiki i prava*(in Russian), No. 1–2, P. pp. 108– 119.
- [7] Marisheva L.T., Medetova K.M., “Methods for assessing personnel risks”, Materials of the republican “*Current problems, achievements and innovations of modern science*”, dedicated to the memory of Academician Radzhabova T.D., 2023, pp. 67-70.
- [8] <https://happy-job.ru/metody-ocenki-personala/> Personnel assessment methods, types and examples of use.
- [9] <https://peopleforce.io/ru/blog/gajd-metody-otsenki-personala/> Personnel assessment methods.
- [10] Silantyeva E.A., Semina A.P., “Motivation and stimulation of personnel at enterprises of high-tech industries”, Gagarin readings-M.: *Moscow Aviation Institute* (national research university), 2018, pp. 152-153.
- [11] Medetova K.M., “Ensuring the accuracy of the selection and evaluation of candidates based on the method of multi-criteria analysis”, *Bulletin of TUIT: Management and Communication Technologies*, № 4(23), 2023.
- [12] <https://testwork.io/blog/metody-ocenki-sotrudnikov/> Definition, goals and objectives of employee evaluation.



UDC: 656,656.2

## IMPROVING METHODS FOR DETERMINING REQUIRED NUMBER OF TRAIN LOCOMOTIVES

**Jumaev Sherzod Bahrom ugli,**  
*Assistant Professor (PhD),*  
*Tashkent State Transport University.*

**Akhmedova Muslima Djalalovna,**  
*Senior Teacher,*  
*Tashkent State Transport University.*

**Toxtakxodjaeva Mafirat Makhmudovna,**  
*Senior Teacher,*  
*Tashkent State Transport University.*  
[shbjumayev\\_92@mail.ru](mailto:shbjumayev_92@mail.ru)

**Аннотация.** Hozirgi kunda dunyo mamlakatlari temir yo‘l transportida dolzarb vazifalardan biri sifatida yuk poyezdlariga lokomotivlar ehtiyojini oldindan tezkorlik bilan aniqlash bo‘ladi. Ushbu tadqiqot ishining maqsadi yuk poyezdlarining og‘irlik me‘yorlarini hisobga olgan holda poyezd lokomotivlariga bo‘lgan talabni aniqlashdir. Olingan natijalarning ishonchliligini tekshirish uchun namuna sifatida elektrovozlarning A-V temir yo‘l uchastkasidan foydalanish ko‘rsatkichlari tahlil qilindi. Yuk poyezdlariga xizmat ko‘rsatish uchun zarur bo‘lgan elektrovozlarning foydalanish parkini aniqlash algoritmi ishlab chiqildi. Shartli temir yo‘l uchastkasida yuk poyezdlariga xizmat ko‘rsatish uchun zarur bo‘lgan elektrovozlarning parki bosqichma-bosqich aniqlandi.

**Калит so‘zlar:** poyezdlarning tuzish rejasi, lokomotivlar ish unumdorligi, son va sifat ko‘rsatkichlari, grafik va kritik og‘irlik me‘yorlari, lokomotivlar parki, lokomotivlardan foydalanish ko‘rsatkichlari, aylanish uchastkalari, ekipirovka, poyezdlar orasidagi interval.

**Аннотация.** В настоящее время актуальной задачей является оперативное определение потребности в локомотивах для грузовых поездов на железнодорожном транспорте стран мира. Целью исследовательской работы является определение необходимости грузовых локомотивов с учетом весовых норм грузовых поездов. Для проверки достоверности полученных результатов, в качестве примера, были проанализированы показатели использования электровозами железнодорожного участка А-В. Разработан алгоритм определения используемого парка электровозов, необходимого для обслуживания грузовых поездов. Поэтапно определено парк электровозов, необходимый для обслуживания грузовых поездов на условном участке железной дороги.

**Ключевые слова:** план формирования поездов, производительность локомотивов, количественные и качественные показатели, графические и

критические нормы веса, парк локомотивов, показатели эксплуатации локомотивов, участки обращения, экипировка, межпоездной интервал.

**Abstract.** Currently, the urgent task is rapid pre-determine the need for freight train locomotives in the rail transport of countries of the world. The purpose of the research work is to determine the demand for train locomotives, taking into account the weight standards of freight trains. To check the reliability of the results obtained, as an example, the use indicators for railway precinct A-V of electric locomotives were analyzed. An algorithm for determining the used fleet of electric locomotives necessary for servicing freight trains has been developed. The fleet of electric locomotives has been determined step by step necessary for the service of freight trains on the conditional railway section.

**Keywords:** plan formation of trains, locomotive performance, quantity and quality indicators, graphic and critical weight norms, fleet of locomotives, indicators of the use locomotives, turning sections, equipment, the interval between trains.

## Introduction

The use of effective technology in the transportation process, aimed at improving economic indicators in the conditions of a market economy and restructuring of rail transport, increasing the quality of transportation, the prestige and attractiveness of rail transport and the search for ways to implement it, is one of the current issues. It is possible to reduce cost of freight transportation and increase its profitability due to the development and implementation of several systems that affect improvement work of railway transport. One of these is the complex system of controlling the use of locomotives. However, the identification of the demand for train locomotives in a situation where the movement of trains on almost all railways of the world is changing is recognized as one of the pressing issues.

## Literature Review

In The engineering and technical staff of the Railway Research Institute of JSC Russian Railways and the technical department of Railway operation and Central Directorate of locomotive operations and the General Directorate of Locomotive Management of the MPS developed instructions for calculating the required locomotive fleet [1].

Also, scientific work [2] is based on the systematization and generalization of materials related to the operation of locomotives, the analysis of shortcomings in this important branch of rail transport, and recommendations made to further improve the performance of practically tested locomotives. Analytical formulas for determining the time of standing at the turning point of freight locomotives have also been recommended. The scientific work [3] carried out an analysis of the current state of use of freight movement locomotives and scientific work.

The scientific work [4] investigated the effect of the time of standing at a freight locomotive turning point on the locomotive fleet. As a result, it has been found that the waiting time for freight trains at locomotive turning stations at the same operating dimensions varies over a specific range, and it is scientifically substantiated that the

accuracy rate is not high when determining this time magnitude is achieved through analytical formulas.

In scientific works [5–11], train locomotives were studied to increase productivity, automate the process of calculating the used fleet of locomotives, and the effect of the speed of trains on the indicators of the operation of locomotives.

Domestic and foreign scientists have achieved high results in certain periods on the improvement of the train layout plan and the dependence of the weight and length standards of freight trains on the train layout. They are Nekrashevich V., Apatsev V., Rasulov M., Masharipov M., Suyunbayev S and others [1–5, 7–11, 13, 14]. But, the impact of the weight and length standards of structured freight trains on the performance of locomotives at the maintenance stations has not been sufficiently studied.

### Research Methodology

During the research work, graphic and critical weight standards of freight trains (on odd and even lines) were analyzed at the railway sections of Uzbekistan Railways JSC (Figures 1-2).

The productivity of a locomotive depends on its average daily traction distance and the average weight of the train, determined by the following formula

$$W_l = Q_{gr} \cdot \sum N \cdot L, \text{ ton.-km-gross} \quad (1)$$

where is  $Q_{gr}$  – the average weight of freight train, ton.;

$\sum N \cdot L$  – total mileage of locomotives when pulling trains, train-km.

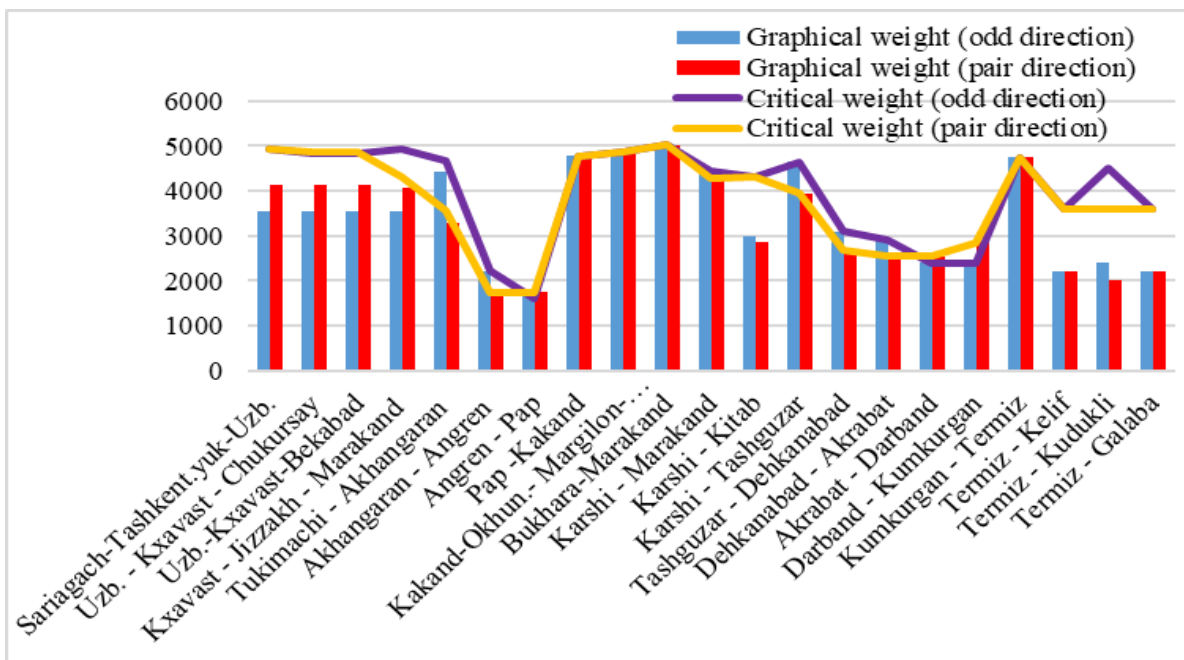
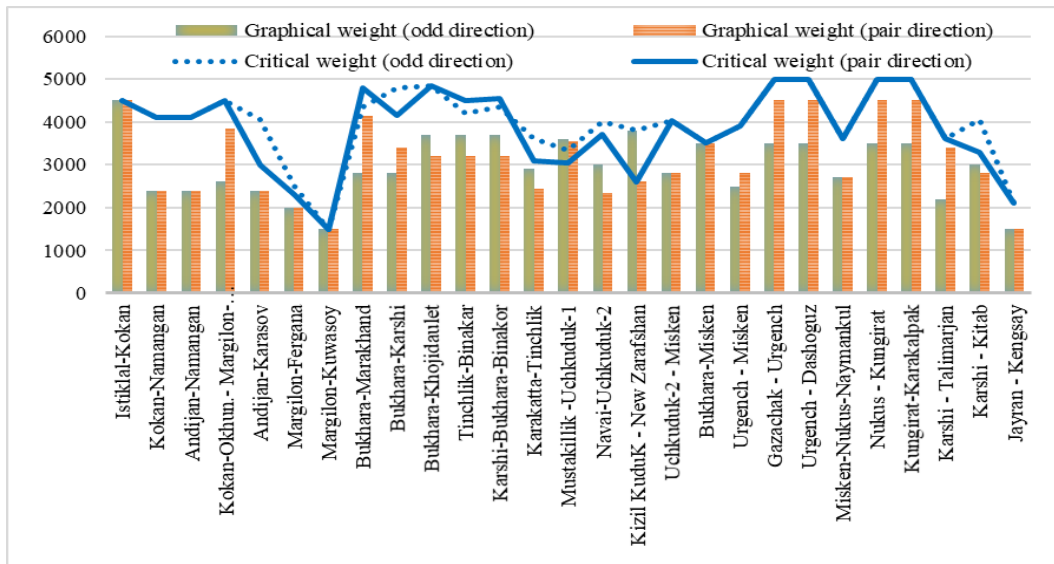

Figure 1. The weight standards of freight trains for the type of electric traction at the railway sections of Uzbekistan Railways JSC.



**Figure 2.** The weight standards of freight trains for the type of diesel locomotive towing at the railway sections of Uzbekistan Railways JSC.

The value of  $Q_{gr}$  is determined from the route sheets of train machinists or is described by the total number of wagons in the composition and their weight

$$Q_{gr} = m_t \cdot q_{gr}, \text{ ton.} \quad (2)$$

where is  $m_t$  – the number of wagons in freight train, wag.;

$q_{gr}$  – the gross weight of wagons, ton.

So, the norms established for the railway precinct (weight and length) affect the productivity of locomotives in the right proportion. If trains are not formatted according to the standards for set of the railway, locomotive performance will decrease. The deviation from the normative number (or norm of weight) of the constituent wagons is determined by the dependence on the performance of locomotives mainly calculated [12], and this connection can be seen in *Figure 3*.

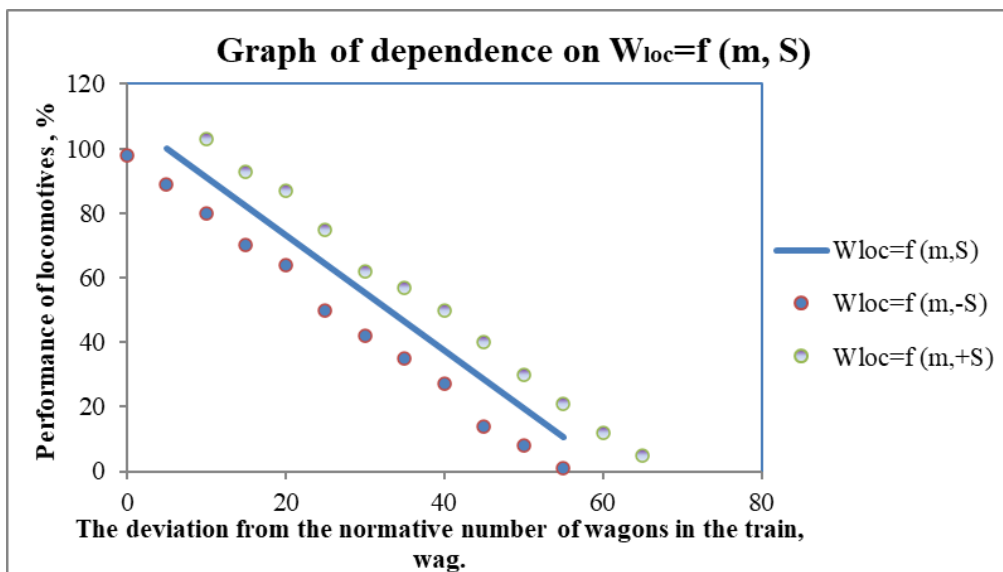

**Figure 3.** Graph of dependence of locomotive performance on the indicator of deviation from the normative number of wagons in the composition.



The basic demand for locomotives is calculated through the following formula:

$$M_o = \theta_p \cdot N/24 \quad (3)$$

where is  $\theta_p$  – accounting turnover of locomotives, time;

$N$  – average estimated dimensions of freight traffic, double of train

The calculation turnover of locomotives is determined by the following formula:

$$\theta_p = \frac{2 \cdot L}{v_y} + \left( \frac{2 \cdot L}{L_{tech}} - 2 \right) \cdot t_{tech} + t'_o + t''_o + \frac{2 \cdot L}{L_{eq}} \cdot t_{eq} \quad (4)$$

where is  $L$  – length of locomotive circulation railway precinct, km;

$v_y$  – railway precinct speed, km / h;

$t_{ech}, L_{tech}$  – respectively, the time of a transit train stopping at technical stations without replacing a locomotive and the distance between these stations, km.;

$t'_o, t''_o$  – minimum technological (accounting) stopping time of locomotives at turning stations;

$t_{eq}, L_{eq}$  – respectively, locomotive equipment time and walking distance between the equipment at the technical stations, km.

The average interval of freight trains running between passenger trains ( $I_{average}$  min.) through time it is possible to determine the basic demand for a fleet of locomotives:

$$M_o = \frac{\theta_p}{I_{average} \cdot 60} \quad (5)$$

In long-range rotation railway precincts  $I_{average} = 1440/N$ , while in short-range railway precincts:

$$I_{average} = \frac{1440 - [\varepsilon_p + 1] \cdot I_p \cdot N_p}{N} \quad (6)$$

where is  $\varepsilon_p$  – coefficient of compression of freight trains by passenger trains;

$I_p$  – the interval between passenger trains in the train action graph (“non-package”), min.;

$N_p$  – number of passenger trains, train.

Using the daily disparity factor ( $y$ ) of the wagon current, one can take into account the increase in the basic demand for locomotives caused by the daily disproportionate movement of the wagon current to  $M_o^n$ , i.e.:

$$M_o^n = M_o \cdot y \quad (7)$$

$y$  - is the change in the flow of wagons, which is equal to the value of the average quadratic deviation between the maximum and minimum value of the wagon flow  $\sigma$  increased by one and a half, i.e.:

$$y = \frac{1.5 \cdot \sigma}{u} \quad (8)$$

### Analysis and Results

On the basis of the above mathematical analysis, we determine the circulation sections of freight trains and the performance indicators of locomotives moving in them. And on this basis, we will create an algorithm for determining the fleet of electric locomotives needed to serve freight trains on a given conditional railway section.

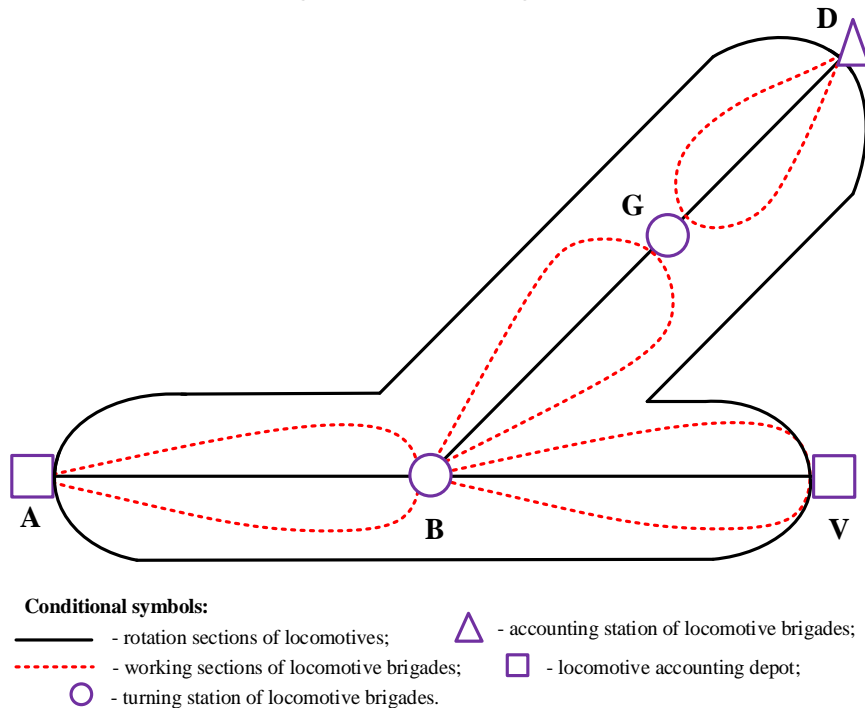
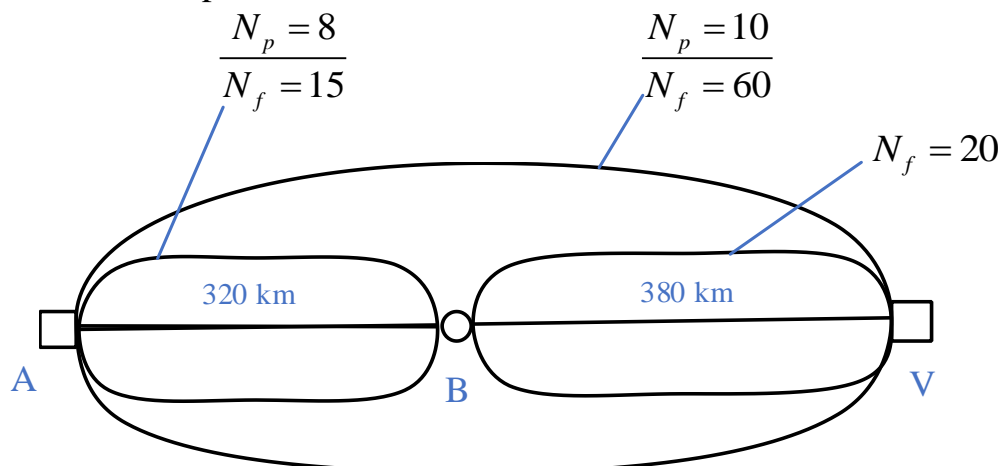

**Figure 4.** Rotation sections of locomotives.

“A-B-D” branched rotation railway precinct of electric locomotives is given (Fig. 4). It consists of four accounting precincts: A-B, B-V, B-G and G-D.

CHS-2 electric locomotives are registered at the depot “A”. All electric locomotives enter Station “A” for the technical inspection (TK-2), which is combined with the performance of the locomotive crew.

Based on Figure 4, an example is given for calculating the park of necessary electric locomotives for railway precincts A-B and B-V, and these calculations were carried out using nomograms and calculation tables. For the A-V rotation railway precinct (conditional railway precinct) of electric locomotives (Fig. 5), the following indicators of use were adopted in Table 1.



**Figure 5.** Scheme of rotation sections and zones of locomotives.

**Table 1.** Indications for the use of electric locomotives for A-V rotation railway precinct.

| Index name   | Traction distance |       |     |
|--|-------------------|-------|-----|
|  | A-V               | A-B   | B-V |
| Length L, km.  | 700               | 320   | 380 |
| Freight train number $N_f$ , pair train                              | 60                | 15    | 20  |
| Number of passenger train $N_p$ , pair train                         | 10                | 8     | -   |
| Railway precinct speed in cargo movement, $v_u$ , km/h               | 50                | 50    | 50  |
| The interval between passenger trains in the “package” $I_p$ , hours | 0.166             | 0.166 | -   |

It is necessary to determine the fleet of electric locomotives necessary for the service of freight trains on the A-V railway precinct.

The algorithm for solving this issue is presented in *Figure 6*.

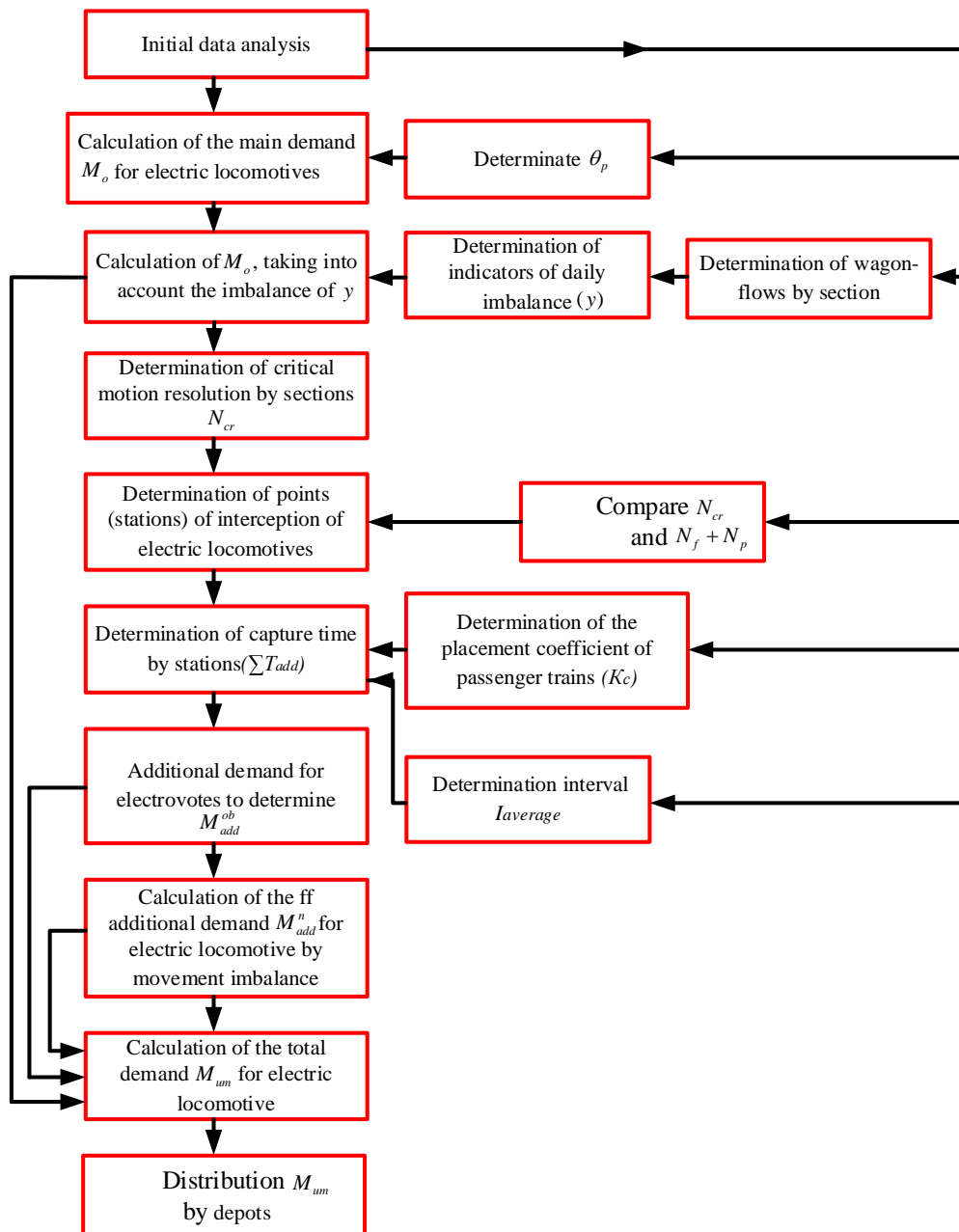

**Figure 6.** Algorithm for determining the use park of electric locomotives necessary for servicing freight trains on a conditional railway precinct.

## Analysis and Discussion

In this research work, it is noted that several scientists have worked on improving the performance of locomotives. Including, in the work of Sidorova E.C. [13] and others are devoted to assessing the change in the specific consumption of energy resources for traction of trains in freight traffic due to changes in the indicators of the use of locomotives at various levels of the organizational structure of Russian Railways.

We will carry out the step-by-step identification of the use park of electric locomotives necessary for servicing freight trains on the conditional railway section:

1. Accounting turnover of electric locomotives on running distance A-V, A-B, and B-V (formula 4):

$$\theta_p^{A-V} = \frac{2 \cdot 700}{50} + \left( \frac{2 \cdot 700}{350} - 2 \right) \cdot 0.5 + 2 + 2 = 33.0 \text{ hours};$$

$$\theta_p^{A-B} = \frac{2 \cdot 320}{50} + 2 + 0.6 = 15.4 \text{ h.}; \quad \theta_p^{B-V} = \frac{2 \cdot 380}{50} + 0.6 + 2 = 17.8 \text{ h.}$$

2. By formula 3, the basic demand for  $M_o$  electric locomotive has been identified. The results obtained are shown in Table 2.

**Table 2.** Results from the approximate rotation of the electric locomotives on the A-B, B-V traction distance.

| Sections | $y$  | $\theta_p$ | $M_o$ | $M'_o$ | $M_{dop}^{ob}$ | $M_{dop}^n$ | $M$   |
|----------|------|------------|-------|--------|----------------|-------------|-------|
| A-V      | 0.13 | 33.0       | 82.5  | 93.2   | 22             | 4           | 119.2 |
| A-B      | 0.21 | 15.4       | 9.6   | 11.6   | ...            | ...         | ...   |
| B-V      | 0.14 | 17.8       | 14.8  | 16.9   | ...            | ...         | ...   |

3. The daily imbalance of wagon current ( $y$ ) leads to an increase in the basic demand for locomotives to a value of  $y+1$ , i.e.  $M'_o = M_o \cdot (y + 1)$

Daily disparity coefficient of wagon-flows:

$$y = \frac{1.5 \cdot \sigma}{U} = \frac{1.5 \cdot \sigma}{N \cdot m} \quad (9)$$

$$y^{A-V} = 1.5 \cdot \frac{312}{60 \cdot 60} = 0.13; \quad y^{A-B} = 1.5 \cdot \frac{128}{15 \cdot 60} = 0.21;$$

$$y^{B-V} = 1.5 \cdot \frac{112}{20 \cdot 60} = 0.14;$$

The  $M'_o$  values for the given railway precincts are listed in Table 2.

4. Additional delays in electric locomotives arise at A and B stations because the volume of traffic approaching these stations is higher than the critical stations calculated by [3], and it is equal to  $N_g^{A-B} = 60 + 15 = 75$  pairs of freight trains for railway precinct A-B,  $N_g^{B-V} = 60 + 20 = 80$  pairs of freight trains for railway precinct "B-V". The calculation of the demand for electric locomotives for railway

precincts “A-B” and “B-V” is carried out similarly to the following calculation for railway precincts A-V. The results of the calculations are given in Table 2.

5. Additional delays at stations A and B to calculate  $M_{add}^{ob}$  by [3] are  $\sum T_{add}$ . To do this, according to [2], the coefficient  $k_s$ , which ensures that passenger trains on sections A-B and A-V are located in proportion to the train traffic graph, and the average interval between goods trains running between passenger trains according to formula 6,  $I_{average}^{AB}$  must be calculated.

For railway precinct A-B:

$$k_s^{A-B} = 0.8 + 0.2 \cdot (10 + 8) = 4.4;$$
$$I_{average}^{AB} = \frac{1440 - (3 + 1) \cdot 10 \cdot 18}{75 \cdot (1 + 0.21)} = 8 \text{ min.} \approx 0.133 \text{ hours.}$$

For railway precinct A-V:

$$k_s^{A-V} = 0.8 + 0.2 \cdot 10 = 2.8;$$
$$I_{average}^{AV} = \frac{1440 - (3 + 1) \cdot 10 \cdot 10}{80 \cdot (1 + 0.13)} = 11.5 \text{ min.} \approx 0.191 \text{ hours.}$$

With passing passenger trains, the additional demand caused by imbalances in the arrival and departure of freight trains, i.e. delays at turning stations, is defined as follows [3]:

$$M_{add}^n = \frac{508.5}{24} + 0.5\Pi \cong 22 \text{ electric locomotives}$$

For the total “A-B” rotation railway precinct, the accounting turnover of locomotives was 33 hours, that is, since it exceeds the planning period by 24 hours, a certain complexity of control occurs under disproportionate driving conditions, to eliminate which additional electric locomotives are needed, and it is calculated according to [2] for railway precinct A-V:

$$M_{add}^{ob} = \frac{33 \cdot 60 \cdot 0.13}{24} \left( \frac{33}{24} - 1 \right) = 4 \text{ electric locomotives}$$

## Conclusions

In conclusion, it can be said that:

1) The higher the deviation of the constituent wagons from the normative number, the less the efficiency of the locomotive will be. This creates additional economic costs in place.

2) Thus, the transfer of traction rolling stock to private ownership with the loss of universality of its use will slow down the movement of car traffic due to the length of downtime at the station waiting for a locomotive by 35-40% or will require an expansion of the locomotive fleet by at least 20%.

3) To determine the used fleet of locomotives required to serve freight trains at a railway site, it is necessary to carry out work to distribute the traction units at the main depot proportionally to the total circulation of the locomotives at each depot. This will cause a significant change in the performance of locomotive use in the future.

### Reference:

- [1] Masharipov M.N., Rasulov M.K., Rasilmukhammedov M.M., and Suyunbaev S.M., “Calculation of the operated fleet of freight locomotives by graph analytic method in the programming language C#”, *Intellectual Technologies on Transport*, 17, 2019, pp. 5–12.
- [2] Nekrashevich V., Apatsev V., “Operation management of locomotives”, *RGOTUPS Press*, Moscow, 2004.
- [3] Ayzinbrud C., Kelperis P., “Operation of locomotives”, *Transport Press*, 2nd edition, Moscow, 1990, p. 261.
- [4] Masharipov M., et. al., “Issues of regulation of train locomotives of the railway section Chukursay-Saryagash”, *Journal of Tashkent Institute of Railway Engineers*, 15 (3), 2019, pp.144–54.
- [5] Jumayev S., et. al., “Assessment criteria for optimization of parameters affecting local wagon-flows at railway sites”, In: D. Bazarov (ed.) *EDP Sciences: E3S Web of Conferences*, Tashkent, Uzbekistan, April 1-3, vol. 264, 2021, p. 05022. <https://doi.org/10.1051/e3sconf/202126405022>.
- [6] Kadyrov A., Sinelnikov K., et. al., “Studying the Process of Transport Equipment Cooling System Ultrasonic Cleaning”, *Communications, Scientific letters of the University of Zilina*, 24(4), 2022, pp. 288-300. doi: 10.26552/com.C.2022.4. B288-B300
- [7] Jumayev S., et. al., “Measures to reduce the loading of stations depending on their geoposition”, In: A. Muratov (eds.) *EDP Sciences: E3S Web of Conferences*, Tashkent, Uzbekistan, January 25-28, vol. 371, 2023, p. 06011 [doi.org/10.1051/e3sconf/202337106011](https://doi.org/10.1051/e3sconf/202337106011)
- [8] Aripov N., Suyunbaev S., et. al., “Method for substantiating the spheres of application of shunting locomotives at sorting stations”, In: D. Bazarov (ed.) *EDP Sciences: E3S Web of Conferences*, Tashkent, Uzbekistan, April 1-3, vol. 264, 2021, p. 26405048. [doi.org/10.1051/e3sconf/202126405048](https://doi.org/10.1051/e3sconf/202126405048).
- [9] Abdurakhmanov A., Khudayberganov S., Khusenov U., and Jumayev S., “Mathematical model of criteria for a comprehensive assessment of the state of railway transport infrastructure”, In *EDP Sciences: E3S Web of Conferences*, vol. 402, 2023, p. 06006. [doi.org/10.1051/e3sconf/202340206006](https://doi.org/10.1051/e3sconf/202340206006)
- [10] Suyunbayev S., et. al., “Improving the use of shunting locomotives based on changes in the infrastructure of railway station”, In: D. Bazarov (ed.) *EDP Sciences: E3S Web of Conferences*, Tashkent, Uzbekistan, August 22-24, vol. 365, 2022, p. 05011. [doi.org/10.1051/e3sconf/202336505011](https://doi.org/10.1051/e3sconf/202336505011)
- [11] Aripov N., et. al., “The technology of shunting operations divides a group of Wagons in the freight train into two directions”, In: *AIP Conference Proceedings*, AIP Publishing LLC, Vol. 2612, No. 1, 2023, p. 060022. [doi.org/10.1063/5.0114454](https://doi.org/10.1063/5.0114454)
- [12] “Rules of traction calculation for train operation” *Press of Transport*, Moscow, 1985.



- [13] Sidorova E., et. al., “Influence of indicators of use of locomotives on the consumption of energy resources in freight traffic”, *Ural transport*, 1(48), 2016, pp. 41–45.
- [14] Galitsky A., et. al., “Prospects for the use of private locomotives on the Russian Railways network”, *Ural transport*, 1(60), 2019, pp. 106–110.

UDC: 004,004.41,005.5

## ANALYSIS OF STREAM ENCRYPTION ALGORITHMS IN *eSTREAM* PROJECT EASY TO USE IN SOFTWARE FORM

**Khudoykulov Zarifjon Turakulovich**

*Associate Professor (PhD),*

*Tashkent University of Information Technologies  
named after Muhammad al-Khorazmi,*

**Rakhmatullayev Ilkhom Raxmatullayevich**

*Associate Professor (PhD),*

*Samarkand branch of the Tashkent University  
of Information Technologies named after  
Muhammad Al-Khorazmi,*

[Ilhom9001@mail.com](mailto:Ilhom9001@mail.com)

**Boykuziyev Ilkhom Mardonakulovich**

*Associate Professor (Ph.D),*

*Tashkent University of Information Technologies  
named after Muhammad al-Khorazmi.*

**Allanov Orif Menglimurodovich**

*Associate Professor (Ph.D),*

*Tashkent University of Information Technologies  
named after Muhammad al-Khorazmi.*

**Annotatsiya.** Ushbu maqolada *eSTREAM* loyihasining oqimli shifrlash algoritmlarini chuqur tahlil qilinadi. Bu tahlil, loyihaing maqsadi, uning ikki asosiy profili (dasturiy ta'minot va qurilma uchun mos algoritmlar), va tanlangan algoritmlar haqida to'liq ma'lumot beradi. Shuningdek, algoritmlarning xavfsizlik muammolari, qurilmada amalga oshirish qiyinchiliklari, va yangi kriptotahlil usullarining algoritmlarga ta'siri kabi muhim masalalarga ham e'tibor qaratilgan. *eSTREAM* loyihasi doirasida tanlangan algoritmlar (Salsa20, Rabbit, Grain va boshqalar) va ularning xususiyatlari, shuningdek, qurilma va dasturiy ta'minotda samarali ishlashi haqida batafsil ma'lumot berilgan.

**Kalit so'zlar:** *eSTREAM* loyihasi, oqimli shifrlash algoritmlari, dasturiy ta'minotda samarali algoritmlar, qurilmada samarali algoritmlar, xavfsizlik muammolari, kriptotahlil usullari, Salsa20, Rabbit, Grain, Trivium, MICKEY 2.0

**Аннотация.** В данной статье представлен углубленный анализ алгоритмов потокового шифрования проекта *eSTREAM*. Этот анализ предоставляет

подробное описание цели проекта, двух его основных профилей (алгоритмы программного обеспечения и устройства) и выбранных алгоритмов. В нем также основное внимание уделяется важным вопросам, таким как проблемы безопасности алгоритмов, проблемы реализации устройств и влияние новых методов криптоанализа на алгоритмы. Подробно описаны выбранные в рамках проекта *eSTREAM* алгоритмы (Salsa20, Rabbit, Grain и др.) и их свойства, а также их эффективная работа в аппаратном и программном обеспечении.

**Ключевые слова:** проект *eSTREAM*, алгоритмы потокового шифрования, эффективные программные алгоритмы, эффективные аппаратные алгоритмы, проблемы безопасности, методы криптоанализа, Salsa20, Rabbit, Grain, Trivium, MICKEY 2.0.

**Abstract.** This article provides an in-depth analysis of the streaming encryption algorithms of the *eSTREAM* project. This analysis provides a detailed description of the project's purpose, its two main profiles (software and device-specific algorithms), and the selected algorithms. It also focuses on important issues such as algorithm security issues, device implementation challenges, and the impact of new cryptanalysis methods on algorithms. Algorithms selected within the *eSTREAM* project (Salsa20, Rabbit, Grain, etc.) and their properties, as well as their efficient operation in hardware and software, are detailed.

**Keywords:** *eSTREAM* project, stream encryption algorithms, efficient algorithms in software, efficient algorithms in hardware, security problems, cryptanalysis methods, Salsa20, Rabbit, Grain, Trivium, MICKEY 2.0

## Introduction

The *eSTREAM* project, led by the European Institute of Cryptography (ECRYPT) and launched in 2004, is an international initiative to select and promote stream encryption algorithms. The goal was to define reliable and efficient stream encryption algorithms for various data transmission conditions. This project presents continuous encryption algorithms suitable for two types: software and hardware. The first group of algorithms consists of algorithms that are easy to program and are faster than the 128-bit AES-CTR algorithm. Finalist ciphers belonging to this group consist of Salsa20/12, Rabbit, HC-128 and SOSEMANUK algorithms [1]. The ciphers belonging to the second group consist of device-friendly algorithms, which are required to be easier to implement on the device than the 80-bit AES algorithm. In this group, the finalist algorithms were: Grain, Trivium and MICKEY 2.0 [2].

Many algorithms were involved in this project. However, some of them left the competition due to security issues, and for some, difficulties in the implementation of the device caused them to be unable to participate. As part of the *eSTREAM* project, many streaming encryption algorithms have been tested, in which 34 encryption algorithms have been considered. Among these algorithms, only two synchronous ciphers were found to be insecure, which limited their participation in the project. Also, some algorithms were excluded from the contest due to security issues or due to implementation difficulties in the device view. Algorithms remaining in the final stage were analyzed using new cryptanalysis methods, which revealed serious security



problems for some of the finalist algorithms. This case shows the importance of new analysis methods in the field of cryptography and the need to constantly test the security of algorithms. The finalist algorithms were also analyzed using methods that were more effective than the full key selection attack. However, these new cryptanalysis methods presented serious security issues for some of the finalists [3].

In the process of selecting algorithms suitable for the Light-Weight Cryptography (LWC) environment, the Grain and Trivium algorithms were selected. Therefore, a closer look at these two algorithms will be given. In addition, algorithms belonging to the first group, such as Salsa and Rabbit, have been noted to be suitable for use in the LWC environment as they require less resources [4].

### Research Methodology

Ciphers suitable for software implementation are algorithms of the first group. Salsa20 was developed by Daniel J. Bernstein and is one of the eSTREAM project software finalists. It has speed and good security features, making it perfect for a variety of applications. *Salsa20/r*"r" stands for the number of iterations of the round function, and the algorithm uses 256-bit keys and 128-bit IVs. Three variants of this algorithm have been developed for different applications, taking into account security and implementation capabilities. The Salsa20/20 variant is designed for typical cryptographic applications, while the Salsa20/12 and Salsa20/8 variants are suitable for environments that require high speed but low security compatibility. This algorithm consists of simple addition, addition modulo 232, bitwise shift, and ARX operations for ease of implementation in software (Figure 1). In this algorithm, data encryption and decryption are the same, which ensures speed. Since these algorithms are fast algorithms, they are included in the Crypto<sup>++</sup> cryptographic library [5].

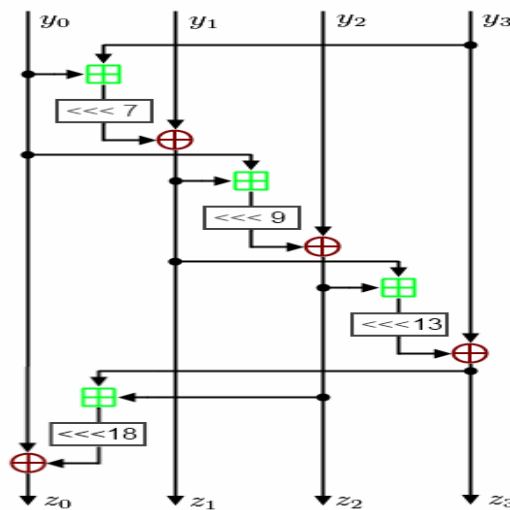

**Figure 1.** Salsa20 algorithm *quarterround*( $y_0, y_1, y_2, y_3$ ) function.

The representation of this 4-round function based encryption function in Python programming language is given below:

```
def quarter_round(a, b, c, d):
    "Quarter Round function of Salsa20 algorithm."
    b ^= rotate_left(a + d, 7)
    c ^= rotate_left(b + a, 9)
    d ^= rotate_left(c + b, 13)
```

```
a ^= rotate_left(d + c, 18)
return a, b, c, d
def rotate_left(value, bit_count):
    "Shift the specified number to the left."
    value &= 0xffffffff
    return ((value << bit_count) | (value >> (32 - bit_count))) & 0xffffffff
def salsa20_block(output, input):
    "Salsa20 block cipher function."
    x = list(input) # Copy the input values
    for i in range(0, 20, 2): # repeat 10 times, 2 rounds each time
        # Odd rounds
        x[0], x[4], x[8], x[12] = quarter_round(x[0], x[4], x[8], x[12])
        x[5], x[9], x[13], x[1] = quarter_round(x[5], x[9], x[13], x[1])
        x[10], x[14], x[2], x[6] = quarter_round(x[10], x[14], x[2], x[6])
        x[15], x[3], x[7], x[11] = quarter_round(x[15], x[3], x[7], x[11])
        # Even rounds
        x[0], x[1], x[2], x[3] = quarter_round(x[0], x[1], x[2], x[3])
        x[5], x[6], x[7], x[4] = quarter_round(x[5], x[6], x[7], x[4])
        x[10], x[11], x[8], x[9] = quarter_round(x[10], x[11], x[8], x[9])
        x[15], x[12], x[13], x[14] = quarter_round(x[15], x[12], x[13], x[14])
    for i in range(16):
        output[i] = (x[i] + input[i]) & 0xffffffff
    # To use for example
    output = [0] * 16
    input = [i for i in range(16)]
    salsa20_block(output, input)
    print(output)
```

In this code, the function `rotate_left` is used to rotate the specified number to the left, which is one of the main operations of the Salsa20 algorithm. In the function `salsa20_block`, the main encryption process is performed.

The most optimally written software version of this algorithm has a size of 1452 bytes and requires 18400 tacts (cycles) for encryption. The most optimally implemented device requires 12126 logic elements (Gate Equivalent, GE), which is not suitable for LWC (300 GE is required for LWC by many researchers). Attacks are mentioned for the smallest version of the algorithm, but there are almost no attacks for the Salsa20/12 and Salsa20/20 variants other than the full key selection attack [6].

*Rabbit* is a synchronized continuous encryption algorithm that, with its powerful features, provides a reliable encryption solution in software systems. The speed and efficiency of this algorithm especially meet the requirements of modern software applications. The application of Rabbit is important in ensuring data security in various systems [7].

In addition, the Rabbit algorithm is recognized by the ISO/IEC 18 033-4:2011 standard, which confirms its security level and reliability at the international level.

Standardization provides the basis for global recognition of Rabbit and its use in systems with strict security requirements [8].

This algorithm consists of simple and basic operations suitable for modern processors. This algorithm provides strong non-linearity based on NFSR and S-table. In this algorithm, nonlinearity is provided based on the chaotic map.

Rabbit uses a 128-bit key length and a 64-bit IV, which provides a high level of security. These parameters are compatible with modern cryptographic standards and are competitive with the widely used AES (Advanced Encryption Standard). To implement this algorithm on a Pentium 4 processor with a speed of 1.7 GHz, it requires 1976 bytes of memory. It takes about 486 cycles and 5.1 cycles to set the key and encrypt each byte. These figures show that Rabbit is an efficient algorithm with low resource requirements, which makes it well suited for small devices. 3800 GE (Gate Equivalent) is required for the implementation of the algorithm in devices. This enables efficient use of Rabbit in microcontrollers, IoT (Internet of Things) devices, and other resource-constrained systems [9].

On average, 128 to 256 perturbations are required in a practical perturbation attack against the Rabbit algorithm. A 241.6-byte table and 238 steps are required to restore the full internal state. This information is important in evaluating the security level of the algorithm and it is considered to be able to provide a certain level of security.

These features make the Rabbit algorithm a cryptographic solution that is reasonably secure, resource-efficient, and efficient on a variety of devices. However, like any cryptographic algorithm, Rabbit must regularly undergo extensive analysis to assess its security and identify potential vulnerabilities [10].

In order to express the Rabbit algorithm in a simple way in Python, some of the basic structures of the algorithm can be presented. Here are the basic functions and part of the encryption process for the Python representation of the Rabbit algorithm.

```
def g_func(x, y):  
    "Rabbit Algorithm Function g."  
    # Separate 16-bit lower part and upper part  
    x_low = x & 0xFFFF  
    x_high = x >> 16  
    # Calculate the square and apply the modulus  
    g = ((x_low * x_low) >> 17) + x_low * x_high  
    g = g >> 15 + x_high * x_high  
    g = g ^ y  
    return g & 0xFFFFFFFF # Limit the result to 32 bits  
def rabbit_cipher(key, iv):  
    "A Simpler Version of the Rabbit Encryption Algorithm."  
    # Set initial state  
    x = [0] * 8  
    c = [0] * 8  
    # The process of setting the initial state based on the key and IV  
    # Special logic is needed to set the key and IV here  
    # This part shows the complexity of Rabbit's algorithm and is not shown  
    # Main cycle
```

```
for i in range(8):
    c[i] = (c[i] + g_func(x[i], x[(i+1) % 8])) & 0xFFFFFFFF
    x[i] = (x[i] + c[i]) & 0xFFFFFFFF
# The updated values of x are returned as the result
return x
# Installation of switch and IV
# Here key and iv are set, not default values for this example
key = [0x91, 0x28, 0x13, 0x29, 0x2E, 0x3D, 0x36, 0xFE, 0x3B, 0x44, 0xAE,
0xF8, 0xC6, 0xD1, 0x5E, 0x38]
iv = [0x59, 0x7E, 0x26, 0x38, 0xD5, 0x29, 0x3F, 0x51]
# Run the Rabbit algorithm
encrypted_data = rabbit_cipher(key, iv)
print("Encrypted data:", encrypted_data)
```

This code shows the complexity of the Rabbit algorithm and how it can be expressed in the Python programming language. However, this example only shows the basic structure of the algorithm and does not provide a complete implementation. A complete implementation of Rabbit's algorithm involves key mixing, IV handling, and data encryption/decryption, which requires more complex and detailed code.

*Device-specific encryption algorithms are the second group of algorithms.*

Grain's seamless encryption algorithm is known for its high efficiency and small size, especially for device flexibility. Its main purpose is to provide a high level of security in low-resource environments, such as sensor networks or IoT (Internet of Things) devices. The Grain algorithm uses Linear Feedback Shift Register (LFSR) and Non-linear Feedback Shift Register (NFSR), which gives it a high level of randomness and security features.

The Grain algorithm is widely used in many application fields, especially in the IoT field, because it is highly adaptable to devices, while providing high efficiency and security [11].

Grain's algorithm uses 80-bit keys and 64-bit IVs. This algorithm requires 1294 GE to run at 1 bit/cycle and 3239 GE to run at 16 bit/cycle. In a software implementation, representing a 1 bit/cycle state is equivalent to 778 bytes of code, requiring 107366 cycles to configure the cipher and 617 cycles to print the result [12].

The Trivium encryption algorithm is a continuous (streaming) encryption algorithm that perfectly balances efficiency, flexibility, and security. This algorithm, which has reached the final stage of the eSTREAM competition and is standardized for Lightweight Cryptography (LWC) within the framework of ISO/IEC 29192-3:2012, is especially designed for use in resource-limited devices [9].

Due to the simplicity of this algorithm, many attacks have been made against it. Recovering the internal state using an improved differential tampering attack required 2 corrupted tampers and a 420-bit key sequence [13].

MICKEY 2.0 (Mutual Irregular Clocking KEYstream generator) is the third finalist in the eSTREAM project's Algorithms for Devices group. This algorithm is especially designed for use in wired and wireless communication networks, as well as in resource-

constrained devices. The main feature of MICKEY 2.0 lies in its unique clocking mechanism, which distinguishes it from other stream ciphers.

The improved version of MICKEY 2.0, with updates aimed at increasing its practicality and security, is a prominent among seamless encryption algorithms used in resource-constrained devices. These updates ensure that the algorithm works effectively in various communication systems, especially in wireless networks and IoT devices.

In addition to the eSTREAM concourse, continuous ciphers for LWC are standardized by the International Organization for Standardization/International Electrotechnical Commission 29192-3:2012. This standard included two continuous ciphers: Trivium and Enocoro. Figure 1 shows an overview of these two ciphers.

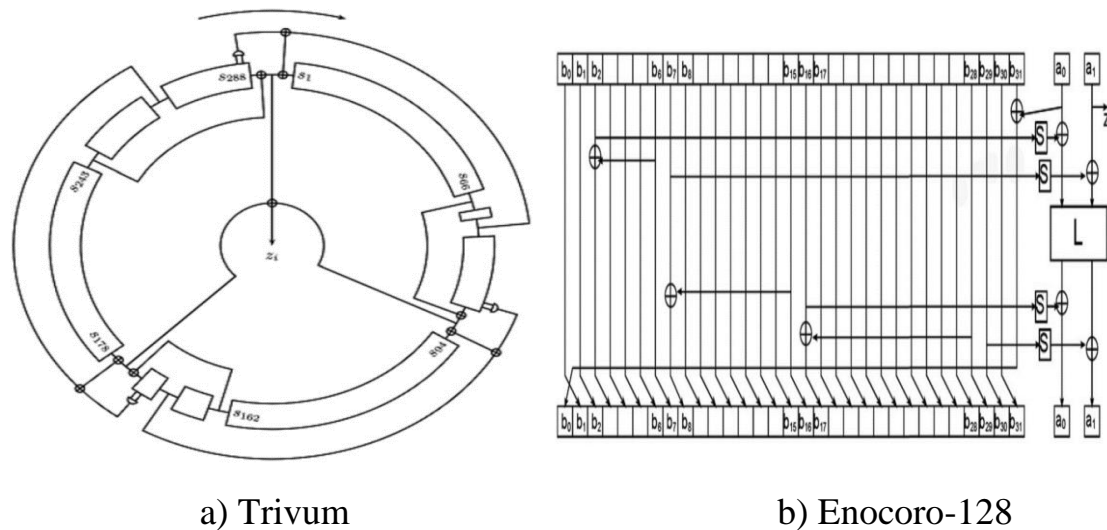

Figure 2. Standardized drafts of Trivium and Enocoro ciphers.

The Trivium cipher is a finalist in the eSTREAM competition for device-friendly algorithms and is analyzed above. The Enocoro cipher was introduced by Hitachi in 2007 and standardized on 4 algorithms provided by them. This algorithm achieves the AES encryption algorithm with 1/10 the power consumption of the encryption process.

The Encoro family of ciphers consists of the Enocoro-80 and Enocoro-128 ciphers, which use 80- and 128-bit keys, respectively. The Encoro cipher uses a 64-bit IV and provides nonlinearity based on a byte-based S-table. These algorithm reflections are easy to implement both in hardware and software. This algorithm generates 1 byte per round and allows 264 bytes to be generated with each key/IV pair.

In terms of device appearance, the Encoro-80 version requires 2700 logical elements, while the Encoro-128 has 4100[14].

In software view, the Encoro-128 cipher takes 4869.5 cycles to run, while it takes 46.3 cycles to generate one byte. While the initialization phase of this algorithm takes as long as Trivium, the encryption process is faster than the AES-CTR and Grain algorithms. No practical attacks have been made on this algorithm and therefore it is considered fast.

## Analysis and Results

A comparative analysis of stream encryption algorithms selected within the eSTREAM project can be presented in the following table. This table includes the main

features of the algorithms, including their level of security, implementation efficiency, and specific areas of application. The purpose of the table is to show the differences between the various algorithms and highlight the distinct advantages of each.

**Table 1.** Comparative analysis of selected stream encryption algorithms within the eSTREAM project.

| Algorithm         | Key Length | IV Length            | Security Level | Hardware Implementation (GE) | Software Implementation   | Private Advantages                         |
|-------------------|------------|----------------------|----------------|------------------------------|---------------------------|--|
| <b>Grain</b>      | 80 bits    | 64 bit               | Good           | 1294 (1 bit/s)               | Efficient                 | Optimized for resource-constrained devices |
|                   |            |                      |                | 3239 (16 bit/s)              |                           | A balance of speed and security            |
| <b>MICKEY 2.0</b> | 80 bits    | 0-80 bits (variable) | Good           | 3188                         | Memory efficiency is good | A delicate clock mechanism                 |
| <b>Trivium</b>    | 80 bits    | 80 bits              | Good           | 3550                         | Efficient                 | Ability to generate long bit sequences     |
|                   |            |                      |                |                              |                           | Safety and efficiency                      |

This table provides a comparative analysis of stream encryption algorithms selected and widely used within the eSTREAM project. Each algorithm has its own characteristics and applications, which make them suitable for different software and hardware environments.

## Conclusions

This article presents a comparative analysis of the features, security level, software and hardware implementations of stream encryption algorithms selected and analyzed within the eSTREAM project. The eSTREAM project is an international initiative to define efficient and secure stream encryption algorithms for various communication systems. Within the framework of the project, two main groups of algorithms suitable for software and hardware implementation have been selected.

The article also focuses on important issues such as the problems identified in the security level of some algorithms through new cryptanalysis methods and the difficulties of their implementation on the device. This emphasizes the need to constantly test the security of algorithms and improve their ability to resist new threats.

## References:

- [1] Daemen J., "Cipher and hash function design strategies based on linear and differential cryptanalysis," *Doctoral Dissertation*, March 1995, K. U. Leuven.



- [2] Rakhmatullaevich R.I., Mardanokulovich I.B., “Analysis of cryptanalysis methods applied to stream encryption algorithms”, *Artificial Intelligence, Blockchain, Computing and Security*, Vol. 1, CRC Press, 2024, pp. 393-401.
- [3] Rahmatullayev I.R., “Oqimli shifrlash algoritmlari va ularni vujudga kelish sabablari”, *International Journal of Theoretical and Applied Issues of Digital Technologies*, T. 2, №. 2, 2022, pp. 119-128.
- [4] Raxmatullayevich R.I., “Stream encryption algorithms and the basis of their creation”, *Central Asian Journal of Mathematical Theory and Computer Sciences*, T. 3, №. 12, 2022, pp. 165-173.
- [5] Rahmatullayev R.I., “A new key stream encryption algorithm and its cryptanalysis”, *Scientific and Technical Journal of Namangan Institute of Engineering and Technology*, T. 8, №. 1, 2023, pp. 146-157.
- [6] Rakhmatullaev I., “Self-synchronizing (asynchronous) Stream Encryption Algorithms”, *Scientific Collection «InterConf».*, №. 164, 2023, pp. 249-254.
- [7] Rahmatullayev I., “Oqimli shifrlash algoritmlari bardoshliligini differensial va algebraik kriptotahlil usullari yordamida baholash”, *Digital Transformation and Artificial Intelligence*, T. 2., №. 1, 2024, pp. 64-70.
- [8] Rahmatullayev I., et al., “Oqimli shifrlash va ularni kriptografiyadagi o‘rni”, *Interpretation and researches*, T. 2, №. 3, 2024, p. 25.
- [9] Rahmatullayev I., et al., “Oqimli shifrlash algoritmlarining loyihalash usullari”, *Talqin va tadqiqotlar*, T. 1, №. 27, 2024.
- [10] Khudoykulov Z.T., Rakhmatullaev I.R., Umurzakov O.S.H., “NSA algoritmining akslantirishlari tanlanishining xavfsizlik talablarini bajarilishidagi o‘rni”, *International Journal of Theoretical and Applied Issues of Digital Technologies*, T. 6, №. 4, 2023, pp. 97-101.
- [11] Rahmatullayev I., Xudoyqulov Z.T., “Mavjud oqimli shifrlash algoritmlarining qiyosiy tahlili tahlili”, *Potomki Al-Fargani*, T. 1., №. 1, 2024, pp. 129-134.
- [12] Rahmatullayev I.R., “Algebraik kriptotahlil usuli va uning oqimli shifrlash algoritmlariga qo‘llanish asoslari: Algebraic Cryptanalysis Method and Basics of its Application to Stream Encryption Algorithm”, *International Journal of Theoretical and Applied Issues of Digital Technologies*, T. 4, №. 2, 2023, pp. 96-102.
- [13] Khudoykulov Z.T., Rakhmatullayev I.R., “Development of a Software Stream Encryption Algorithm”, *Electronic journal of actual problems of modern science, education and training*, T. 1, 2023, pp. 51-59.
- [14] Raxmatullayevich R.I., “Oqimli shifrlash algoritmlari tahlili”, *Novosti obrazovaniya: issledovanie v XXI veke*, T. 1, №. 6, 2023, pp. 889-893.



UDC:004,004.41,37

## EFFECTIVENESS OF MODERN EDUCATIONAL TECHNOLOGIES

**Boltayeva Shokhida Olimjonovna**

*Senior lecturer,*

*Termez State University,*

[shboltayeva1221@gmail.com](mailto:shboltayeva1221@gmail.com)

**Annotatsiya.** Mazkur maqolada respublikamiz oliy ta'lim tizimida zamonaviy texnologiyalarni qo'llash, ularning imkoniyatlarini tahlil qilish asosida o'quv jarayonini rivojlantirishning ustuvor yo'nalishlari aniqlangan. Shuningdek, oliy ta'limda zamonaviy texnologiyalarni joriy etishga ilmiy asoslangan hulosalar tuzishda mavjud bo'lgan amaliyotni o'rganishlar ko'rib chiqiladi.

**Kalit so'zlar:** Zamonaviy axborot, ta'lim jarayoni, multimediya, IT-texnologiyalari, ta'limning yangi shakllari.

**Аннотация.** В данной статье определены приоритетные направления развития образовательного процесса на основе анализа возможностей применения современных технологий в системе высшего образования Республики. Также будут рассмотрены исследования существующей практики при составлении научно обоснованных выводов о внедрении современных технологий в высшем образовании.

**Ключевые слова:** современная информация, образовательный процесс, мультимедиа, IT-технологии, новые формы обучения.

**Abstract.** This article identifies priorities for the development of the educational process based on the application of modern technologies in the higher education system of our Republic, analysis of their capabilities. Studies of the existing practice are also considered when drawing up scientifically based conclusions on the introduction of modern technologies in higher education.

**Keywords:** modern information, educational process, multimedia, IT technologies, new forms of Education.

### Introduction

Today, very strict and complex requirements are imposed on the organization of the educational process. Because, the social need to train qualified specialists who can work with complex techniques, have a full-fledged understanding of the essence of the production process, can positively solve problems that arise even in emergency situations, assumes the organization of the educational process on the basis of a technological approach. Teaching methods will belong to one or another classification, based on a certain pedagogical theory in its essence and content. In the content of the law "education program" of the Republic of Uzbekistan and the "National Program of training", each stage of the process of raising a competent person and a qualified specialist should carry out certain tasks in order to effectively organize the educational process in itself, to raise it to higher levels, at the same time to the level of education that can meet the requirements of Issues related to the legal aspects of ethical, personal data protection, competition between employees of robots and organizations, based on



the use of numbers and with the unconditional benefit of the introduced technologies, are increasingly being considered. In this regard, as the president of our country Shavkat Mirziyoyev noted, “in order to achieve progress, it is necessary and necessary for us to master digital knowledge and modern information technologies. This gives us the opportunity to follow the shortest path of ascent. After all, today Information Technology is deepening into all areas of the world. Of course, we know very well that the formation of a digital economy requires the necessary infrastructure, a lot of funds and labor resources. However, no matter how difficult it is, when do we get into this business if we don't start today?! Tomorrow will be too late” [1].

### **Research Methodology**

Today, the role of innovative technologies, technical means, including modern computers, in the correct and effective organization of the educational process is incomparable. The use of multimedia, animation, graphics, diafilms and videos on the topic of the lesson will help to make the lesson process more interesting, for this, the teacher should work on himself and ask himself the question “with what innovation I can enter today's lesson process and organize the lesson more interesting”, that is, he should try to avoid traditional education and give [7] in the organization of the course process using modern information technology, the teacher initially:

- purpose of the lesson;
- ways to achieve the goal;
- methods of providing educational materials;
- teaching methods; - types of teaching assignments;
- questions for discussions;
- ways to organize debates and debates;
- it will be necessary to identify factors such as communication methods and communication [2].

### **Analysis and Results**

The didactic system of modern educational technologies follows from the fact that two sides – teaching and reading – constitute integrity in the educational process and serve as the subject of didactics. Programmed, problematic, developmental training of modern educational technologies (P.Galperin, L.Zankov, V.Davidov), humanistic (humanitarian) psychology (K.Rodgers), cognitive psychology (J. Bruner), 80's teacher in Russia- it organizes such directions as pedagogical technology of innovators, cooperation pedagogy, distance education, modular education [6]. Developing educational technologies include technologies for the development of the interests and needs of the person receiving education, individual qualities, knowledge, creative abilities that are strongly manifested in certain areas [8]. In this, the process of teaching, taking into account the capabilities of each learner, is understood as the process that ensures the transition from one qualitative stage to another through an education with a special approach. In education, IT technologies are used when previously educated people want to find an answer to a question, need additional education, only a teacher, and printed books came to the rescue. Today, through the internet, it is possible to instantly turn to educational help in a variety of ways. Examples of innovative forms of teaching include training, roundtable, interactive lecture, interactive excursion,

video conference, VR classes, virtual lecture, virtual excursion, webinars, chatbots, webinars, blended learning (mixed teaching), artificial intelligence-digital teachers, publicly open online courses, etc.[5] it can be said that the use of interactive methods, graphic organizers, problematic methods, debates, game technologies as innovative teaching methods in the educational process. And innovative educational tools can include interactive whiteboard, Smart boards, presentation, multimedia, e - textbook, virtual atlases, virtual simulators, virtual University, virtual campus, technology platforms, educational portal, simulators, virtual libraries, 3D-, 4D-, 5D-tech applications [3]. Innovative educational technologies are based on three main components:

1. Modern, well-built content, the basis of which is competencies in professional activities that respond to the current reality of entrepreneurial activity. the content includes various multimedia materials that are transmitted through modern means of communication.

2. Application of modern, innovative methods in teaching. Such methods should be aimed at the formation of competencies of the future specialist, involving students in active educational and practical activities, taking initiative in the educational process. Passive assimilation of training programs is excluded.

3.The presence of modern infrastructure in the educational process. It should be based on information, technological, organizational and communication components that help to apply new forms and methods of education, in particular distance education. In the current period, when the reforms in the continuous education system of the Republic of Uzbekistan continue to be intense, the need to improve the educational and educational process in the form and content should be the main and main issue on the agenda, and teacher and student cooperation should be further strengthened [4].

## Conclusions

In our opinion, the effectiveness of innovative processes to be introduced into the educational system, as well as the responsibility for fulfilling the requirements of the National Training Program, depend on the conditions for the development and introduction of pedagogical innovations, the purposeful, rational and continuous application of traditional and modern methods of Education. There are cases of abandonment of traditional methods that are effective in some cases. It feels like putting innovation against the teaching methodology that has been tested and tested in the experiment, giving a positive result. That is why it would be better if positive experiences in the traditional educational system were harmonized with innovations.

## References:

- [1] O‘zbekiston Respublikasi Prezidenti Shavkat Mirziyoevning 2020 yil 24 yanvarda Oliy Majlisga yo‘llagan Murojaatnomasi. <https://uza.uz/oz/politics/zbekiston-respublikasi-prezidenti-shavkat-mirziyeevning-oliy-25-01-2020>.
- [2] Payzullakhanov Mukhammad-Sultan Saidvalikhanovich, Xolmatov Abdurashid Abdurakhim ugli, Sobirov Muslim Muhsinjon ugli. “Magnetic materials synthesized in the sun furnace”, *International Journal of Advanced*



- Research in Science, Engineering and Technology*. Vol. 7, Issue 4, 2020, pp. 1499-13505.
- [3] Shoyimova Sh.S., Xoshimova M.K., Mirzayeva Sh.R., Qo'ziboyeva M.M., "Ta'lim texnologiyalari" – Darslik – T.: «IJODPRINT», 2020, p. 310.
- [4] Xujaev V.U., Mamayusupov S., Jumanov A.M. "Podgotovka budushego uchitelya ximii na osnove innovatsionix texnologiy", Uzluksiz ta'lim tizimida matematika va informatika fanlarini o'qitishini takomillashtirish masalalari" *Respublika ilmiy-amaliy konferensiya materiallari*. – Qo'qon, Qo'qDPI, 2012.
- [5] Kovalenko E.M., "Ta'limdagi interaktiv texnologiyalar va elektron ta'lim elementlari", Ta'limni modernizatsiya qilish sharoitida interaktiv ta'limning zamonaviy tizimi. *Ilmiy-metodik konferensiya materiallari*; Janubiy Federal Universiteti). - Rostov-na-Donu: Janubiy federal universiteti nashriyoti. - pp. 47-50.
- [6] Bordovskoy N.V., "Zamonaviy ta'lim texnologiyalari", 2<sup>nd</sup> ed. M.: *KNORUS*, 2011, pp. 432.
- [7] Tursunov I., Nishonaliev U., "Pedagogika", Tashkent, 1996.
- [8] Omonov H.T., "Olamning ilmiy manzarasini yaratishda fanlar integratsiyasi va differentsiatsiyasining o'rni", *Ta'limda ijtimoiy-gumanitar fanlar jurnali*, №3, 2007.
- [9] Gulyamov S.S., Abdullayev M.K., "O'zbekistonda 1-million dasturchi loyihasi amalga oshiriladi", *Ma'rifat gazetasi*. <http://marifat.uz/marifat/ruknlar/fan/4373.html>
- [10] Abdullayev M., "Analysis of application of information systems at industrial enterprises", *Arxiv nauchniix issledovaniy*, 1(20). <https://journal.tsue.uz/index.php/archive/article/view/2270>.



## ACTUAL PROBLEMS IN MODERN ART AND ARCHITECTURE

UDC:78,78.09,780.6

### DEVELOPMENT OF JAZZ PIANO PERFORMANCE IN UZBEKISTAN

**Sadikova Zukhra Sotvoldiyevna**

*Place of work: National Institute of  
Pop Art named after Botir Zakirov*

[@zuxrasadikova1965yun@gmail.com](mailto:@zuxrasadikova1965yun@gmail.com)

**Annotatsiya.** Hozirgi kunda asosan yoshlarga berilayotgan keng imkoniyatlar tufayli iste'dodni namoyon etish qobiliyati unchalik qiyin deb hisoblanmaydi. Yoshlarni qo'llab-quvvatlash, ularga o'zini ko'rsatish uchun keng imkoniyatlar berish hozirgi kunda san'at olamidagi asosiy vazifalardan biri hisoblanadi. Shu bilan birga, musiqada janrlarning bir nechta turlari mavjud va ushbu maqolada mamlakatimizda jazz fortepiano ijrochiligining rivojlanishi, ushbu janrga kiritilgan yangiliklar va shu bilan birga yosh avlodni unga tayyorlash kabi mavzular borasida so'z yuritiladi va muhokama qilinadi.

**Kalit so'zlar:** Jazz, Evropa musiqa madaniyati, bir nechta takrorlash, qo'shiq uslubi, jazz guruhi, musiqiy ansambllar, jazz klublari, xalqaro festivallar, pop musiqa, jazz orkestrlari, kuylar va usullar.

**Аннотация.** В настоящее время, в основном из-за широких возможностей, предоставляемых молодежи, способности проявлять таланты не считается такой сложной задачей. Поддержка молодых людей, предоставление им широких возможностей для самовыражения в настоящее время является одной из главных задач в мире искусства. При этом в музыке существует несколько видов жанров, и в данной статье будут рассмотрены и обсуждены такие темы, как развитие джазового фортепианного исполнительства в нашей стране, нововведения, вошедшие в этот жанр, и одновременно подготовка к нему подрастающего поколения.

**Ключевые слова:** Джаз, европейская музыкальная культура, многократные повторения, стил пения, джаз-бэнд, музыкальные ансамбли, джаз-клубы, международные фестивали, поп-музыка, джазовые оркестры, мелодии и методы.

**Abstract.** Due to the wide range of opportunities that are now mainly given to young people, the ability to show talent has not been considered so difficult. Supporting young people, giving them ample opportunities to show themselves, is now one of the main tasks in the art world. At the same time, there are several types of genres in music. And this article will talk and discuss topics such as the development of jazz piano performance in our country, the innovations introduced into this genre, and at the same time the preparation of the younger generation for it.



**Keywords:** Jazz, European musical culture, multiple repetitions, singing style, jazzband, musical ensembles, jazz clubs, international festivals, pop music, jazz orchestras, melodies and methods.

## Introduction and Literature Review

At the beginning of the word, first of all, jazz begins by giving information about what genre is considered, its history, place of origin, which celebrities have gained popularity in this genre. Jazz (English: jazz) is a type of professional music, one of the main stylistic sources of modern popular, in particular pop music. The late 19<sup>th</sup>-early 20<sup>th</sup> — century fusion of elements of African and European musical culture resulted in the creation of New Orleans African Americans in Louisiana in the United States [1-4]. Signs of the folklore of African peoples — the sound of different ways in one-way, multiple repetitions of the main melody, changing almost every time, rich in characteristic moans, an exciting singing style, executive artistry in a certain direction — have become fundamental features of jazz. Initially, the works created by the participants of the ensemble of 7-8 musicians and performed by themselves were called jazz or “jazband”. Jazz founders L.S. Armstrong, J.K. Oliver, J. Dode, E. K. Ori, J.R. Morton and others were the leaders of such ensembles. They were later joined by Dixieland bands from Takli, who promoted Jazz Art in American and European countries. The 1930’s swing (D. Ellington, U. K. Beysi), 40’s “bibop” (Ch. Parker, D. D. Gillespie), later known as “the Ashes” (M. Davies) and other styles arose, with major jazz orchestras forming. B. Goodman (1962 toured with his orchestra in Tashkent), G. Miller and J. Coltrane (USA), J. Dankworth (England), M. Legran (France), K. Vlack and G. Brom (Czechoslovakia), K. Edelhagen (Germany), K. Komeda (Poland), A. Sfasman, L. Utyosov, O. Lundstrem (Russia) is the founder of famous jazz orchestras. Jazz music in Uzbekistan began to surface in the 2<sup>nd</sup> half of the 1940’s. D. Gillespie in the Cinema, Palace of culture, city parks of such cities as Tashkent, Samarkand, Fergana, Andijan. Sokolov, A. Pozdnyakov, M. Azatyan and others. The musical ensembles that formed under his leadership played samples of jazz and pop music [5-8]. The formation of the Estrada Orchestra of Uzbekistan in 1958 and the Estradasymphonic orchestras under UzTVradio in 1963 were the impetus for the development of jazz. In this, especially A. Kroll, A. Malakhov, Ye. The contributions of conductors such as Zhivayev were significant. “Namangan’s Apple”, (Ramazonov), “Girl Boy” (E. Solihov) of his songs processed options in style, A. Malakhov’s orchestral works “Star Circle”, “black eyes”, written usefully from Uzbek melodies and methods, are among the first examples of national jazz music. Jazz music continued to flourish in the later period. In 1968, the 1st Jazz Music Festival was held in Tashkent; 1977, 1978, 1984 the international festivals of jazz music were held in Fergana; jazz clubs were formed in these cities, jazz groups in Bukhara, Navoi and other cities. Of These, E. Qalandarov, S. Gilyov (“Inter”), L. Otabekov (“Sato”), B. Smetanov (“Raduga”), G. Gurukhs under Kapriyelov (“Asia”) were awarded prizes at the International Jazz Festival and variety competitions. Currently, jazz performers include the Uzbeknavo under the pseudonym. The Zokirov variety orchestra (lit. Jivayev), the Big Band (Jazz Orchestra) of the Tashkent State Conservatory (B. Murtazayev), G. Bugdanov, A. Gurukhs under Khabirkhanov are active.

Samples of Uzbek jazz music were written by the firm “Melodiya”: “Oriental suite” (Tashkent Jazz Club Group), “Efsane” (“Sato” group), etc [9,10].

### **Research Methodology**

Fortepiano (Italian: forte — strong and piano — weak, slow) is the common name of the royal and pianos. In the early 18<sup>th</sup> century. Cristofori (Italy), J. Marius (France) and CA.G. Invented by Schriever (Germany). Later F. mechanism and shape I. A. Stein, I. A. Streicher (Austria), A. Bakers (London), S. Improved by Erar (Paris) and other masters. By pressing the sound Ogeies, felt is chiralized by hitting the strings with coated wooden hammers. The dynamics from the harpsichord and harpsichord differ in their variability (Mas, the possibilities of switching from the strong Peggy to the piano level) (hence the name). F. the first works for I. Gaydn, W. A. Mozart, L. Beethoven and other creations. F. due to its wide range of performance and expressive capabilities, it has been widely featured in European multi-voice music as a major solo and soulful sound. Piano Music in Uzbekistan in 1920-30 V. Uspensky, B. Starting with Uzbek folk tunes, which Nadezhdin reworked, he later became a member of the. Mushel, H. Izomov, B. Giyenko, Saifi Jalil, N. Zokirov, D. in recent years. Saidaminova, R. Abdullayev, A. Nabiyeu, M. Otajonov, D. Omonullayeva and others were rich in miniatures, Sonatas and concertos, multi-part series. A. on the development of the art of piano performance in Uzbekistan. Lisovsky, N. Yablonovsky, artists who served in Uzbekistan O. Yusupova, A. Sharipova, a teacher who served in Uzbekistan. Popovich, winner of international competitions E. Mirkosimova, A. Sultanov, U. Polvonov and others contributed [11-13].

### **Analysis and Results**

In the 60's of the XX century. Early jazz works were displayed in Uzbek folklore fabrics. These are vivid examples of Uzbek jazz, singing games like “Joy” and “Star do'ra”. In 1968, the first Republican jazz music festival in Tashkent, which featured professional teams, was attended by Sympojaz Uzgosteleradio, Big Band Ed modules, such as composer Eduard Kalandarov and others: Sardor Mukhtorov - piano; Konstantin Dobrovolsky-eight - saxophone; Sergey Gilev - two bass; Yuri Parfenov-pipes; percussion instruments of Alexander Trazevsky). In the 70's Jazz musicians are focusing on preparation. During this decade, the Republican jazz club was born, two jazz music festivals were held in Fergana, and the concert activities of jazz bands began to expand. An important factor in the development of jazz performance in the Republic was the opening of another department at the Tashkent music college. The establishment of the Republican circus studio, which began to train Hamza and professional jazz musicians. One of the most interesting works of this period was the Eastern Suite, which took place in 1978 as part of the second Fergana jazz Festival. The suite's music focuses on the national flavor of the Uzbek people. Derived from the Modal and toning, rhythmic foundations that reflect the inherent national identity of his improvisation and the monodic nature of music.

In the 90's in Uzbekistan, children and young people have a desire to participate in jazz music, which opened up new prospects for jazz pedagogy. In 1995, the festival jazz Club was held at the Republican secondary special boarding school named after Uspensky. Interclub's Art Director and children's studio risen “Jazz St Road” - a



brilliant propagandist of jazz art, a talented musician and a teacher who allows Vasiliy Uporov to love jazz and the noble intention of high jazz culture. Each year, the Four Seasons take the “Seasons”, language, environment, writer, and style perspectives to the forefront. The winners of the festival are well-known Jazzmen such as Diana Ziyatdinova, Daniil Halikov, Ksenia Aizel, Rustam Abdullayev, Yulia and Lilia Ugai. Jazz, Performing Arts and Khamza are deliberately taught at the Republican College of music. Jazz education in this ancient educational institution is carried out in two directions: vocal led by Tamara Isayan and instrument of Jamila Naimova. Students of the University participate in international and Republican competitions, winning prizes and confirming the qualification of the Uzbek jazz school. Winners in international competitions are guitarist Andrei Galayan, Elena Fomenko and Anatoly Pak. His work on the development of Jazz art was published by R. Glier can be found at named RSMAL. Dilfuza Zaitova, head of the various department, directs the works of the disciples to search for originals: an in-depth study of the layers of National jazz Art and a search for new forms of interaction. It is important that the Uzbek folk equipment team receive an invitation to the participants of the International Jazz Festival in Japan in March 2008.

Our jazz and pop musicians and singers do well in Western European countries and are pleased with their national impressions of Oriental nature. Especially interesting is the performance of Sevara Nazarkhan. The Uzbek singer of the Batukki festival in Lommel, Belgium was chosen as the new star of Belgian world music. Sevara Nazarkhan performed special tricks by playing BBC radio broadcast songs through a video conference called “Yul Bulsin” (special Yul Bulsin). Nazarkhan’s performances in Germany (Berlin), Switzerland (Edinburgh) and Russia (Moscow) were equally successful. In England, the Uzbek singer is also fond of, in which her abilities, strong melodic tones, movement and expression have long been admired. The British radio channel “BBC” awarded the “rebellion for Asia and the Far East rebellion” award for a folk musician similar to the Grammy. Expanding ties between countries and peoples and contributing to the leading names of Uzbek jazz art. Artist of the Republic of Uzbekistan and worthy of international competitions, Mansur Toshmatov is an artist with a wide range of vocalists who can start their audience with Oriental love. Mansur Toshmatov took the stage with the success of the International Festival “Astana blues-2” (2006), which was attended by musicians from America, Russia, Moldova and Azerbaijan Tashmatov and the rock group “Tashkent” Jiramamaov defeated the audience with their unique abilities. Many are named after the jazz fans republic, such as Botir Zokirov, and Zakirov A. Ikromov is a wonderful dynasty drummer, the symphony orchestra works in an effective way, led by Uzgosteleradio Estrada. Tashkent, which has witnessed a revival when the world opens increasingly in Uzbekistan, has attracted the attention of famous musicians in many countries, as it is becoming a venue for the festival. Countless festivals lovers take the stage together, and it turns into a real Jazz Festival. Their participation is recognized as well-known local bands, soloists and beginner artists. The most important feature of the life of Uzbekistan, Herot Isanbayev and participants Dolphins Gulzarov, Vladimir Teregulov, Bulat Mustaev and other jazz artists, the ability to perform them during the four nights of the author entertained jazz fans with the project “Super Sax”.



## Conclusions and Suggestions

Jazz musicians and singers will be raised in the future in Tashkent in a music school - will enrich the free spiritual world, contribute to the moral development of the spiritual and masses of musical art, artists, a new generation of democratic society people. Jazz is not only musical, but also spiritual state, lifestyle, always important and demanding.

## References:

- [1] “Jazz Origins in New Orleans”, - *New Orleans Jazz National Historical Park*, National Park Service.
- [2] Germuska Joe, “The Jazz Book: A Map of Jazz Styles”. WNUR-FM, Northwestern University.
- [3] Roth Russel, “On the Instrumental Origins of Jazz”, *American Quarterly*, 1952.
- [4] “O‘zbekiston milliy ensiklopediyasi”, O‘zME., Birinchi jild, -Tashkent, *O‘zbekiston milliy ensiklopediyasi Davlat ilmiy nashriyoti*, 2000.
- [5] Robert R., Nor Eddine B., “Jazzology” *The Encyclopedia of Jazztheory for all musicians*, p. 265.
- [6] “O‘zbekiston milliy ensiklopediyasi”, National Encyclopedia of Uzbekistan (in Uzbek), Tashkent: *National Encyclopedia of Uzbekistan State Scientific Publishing House*, 2000–2005.
- [7] *Autbexovet encyclopedia*. T.9. 1976.
- [8] *Muzikalno entsiklopedicheskiy slovar*. M. 1990 g.
- [9] V.Galackaya. *Muzikalnaya literature zarubezhnix stran*. M.1978
- [10] K.Rosenshild. *Istoriya zapadno evropeyskoy muzkki*. M.1965.
- [11] Levik B.V. *Muzikalnaya literature zarubezhnix stran*. M.1979.
- [12] Levik B.V. *Istoriya zarubeznoy muziki*. M.1982.
- [13] Valery Saparov in the jazz style “24 Preludes”.

UDC:78,78.09,780.6

## PIANO MUSIC BY COMPOSER NADIM NORKHODJAYEV: PERFORMANCE INTERPRETATION

**Sadikova Zukhra Sotvoldiyevna**

National Institute of Pop Art  
named after Botir Zakirov

[@zuxrasadikova1965yun@gmail.com](mailto:@zuxrasadikova1965yun@gmail.com)

**Annotatsiya.** Ushbu maqolada bastakor Nadim Norxo‘jayevning fortepiano ijrochiligining amaliy va nazariy tamoyillari bayon etilgan. Sharq musiqasi ta’sirida shakllangan bu kompozitor uslubi musiq va tasvir vositalarining yorqinligi va nafisligi, garmoniya va cholg‘u asboblarning yangiligi, nozik va go‘zal ohanglari bilan ajralib turadi. Bastakor merosi bugungi kun ijodkorlari uchun mavjud kompozitsiya maktablari uchun naqadar muhim ekani ta’kidlandi.





**Kalit so‘zlar:** Nadim Norxo‘jayev, dinamika, tembr, masshtab, tekstura, ritm, konsert, temp.

**Аннотация.** В данной статье описаны практические и теоретические основы игры на фортепиано композитора Надима Норходжаева. Стиль этого композитора, сформировавшийся под влиянием восточной музыки, отличается яркостью и изяществом музыкальных и изобразительных средств, новизной гармонии и инструментовки, нежностью и красотой мелодий. Было подчеркнуто, насколько важно наследие композитора для существующих композиторских школ современных художников.

**Ключевые слова:** Надим Норходжаев, динамика, тембр, гамма, фактура, ритм, концерт, темп.

**Abstract.** This article describes the practical and theoretical principles of composer Nadim Norkhodjajev’s piano performance. This composer’s style, which was formed under the influence of Eastern music, is distinguished by the brightness and elegance of musical and visual tools, the novelty of harmony and instrumentation, and the delicate and beautiful melodies. It was highlighted how important the composer’s legacy is to the existing composition schools for today’s artists.

**Keywords:** Nadim Norkhodjajev, dynamics, timbre, scale, texture, rhythm, concert, tempo.

## Introduction

The art of Uzbek national music, with its rich history and antiquity, has been developing and polishing in its own way for several centuries. In order to preserve and widely promote this heritage, it is appropriate to mention the names of great artists who are of historical significance not only in Uzbekistan, but also on a global scale with their prolific creativity. Since the 20s of the last century, a number of composers and composers have shown great enthusiasm in presenting the national musical heritage to the public in the interpretation of various genres, while preserving the unique national charm and criteria [1-3].

Over the course of a century, after independence, great opportunities were opened for the development of national and secular genres, and these opportunities are giving their results today. To this day, not only national musical genres, but also European genres have developed and are showing their progress on a global scale. Instrumental music, i.e., the traditions of piano performance, are also worthy of praise in the composition of such a series of genres.

By this time, the hard work of studying the musical heritage and re-presenting national melodies to the people for the next generation on the basis of new genres was carried out. One of such great Uzbek composers is Nadim Norkhodjajev.

It can be observed that national melodies are interpreted in a unique way in each of the works created by the composer Nadim Norkhodjajev. One of the great achievements of the era was the fact that creative composers were able to express music in the interpretation of other foreign genres while preserving the spirit of nationalism. For the common people, national melodies in the interpretation of European genres

were first reflected in musical dramas. The appearance of musical dramas has found its expression in the works of composers and dramatists in different ways, both in terms of form and subject of dramatic ideas. After all, among these genres, the attention to the works of the piano instrument also increased. Despite the fact that this instrumental music was new to the Uzbek people, it had its creators in a short period of time.

### **Literature Review and Methodology**

Among the Uzbek composers, Manas Leviyev, Doni Zakirov, Hamid Rahimov, Ibrahim Hamrayev, Fattokh Nazarov, Ikrom Akbarov, Abdurakhim Mukhamedov, Matniyoz Yusupov, Abdusharif Otajonov, Sultan Hayitbayev, and others are historical not only in the creation of Uzbek national musical dramas, but also in the creation of piano pieces. becomes important. New music examples in the harmony of national melodies in the melodies and tunes created for the piano instrument took place in the work of the composers [4-6].

The researchers of Nadim Norkhodjayev's piano works are mainly pianists who devotedly completed their scientific and methodical works, educational and methodological manuals, and textbook sections. These are, first of all, well-known piano teachers, Candidate of Pedagogical Sciences, Associate Professor I.G. Reves, candidate of art history, associate professor L.M. Ganiyeva, laureates of international competitions, professors-teachers MM. Fayziev and E.Z. Mirkosimov [5-8].

Describing the piano music of Nadim Norkhodjayev, it should be noted that it contains the characteristic features of creative individualization. The works of the composer-pianist are practices based on musical performance. In the process of daily communication with the piano, Nadim Norkhodjayev is not only a composer, but also a musician-researcher who explores the possibilities of building the composition of the work. In the process of creating music, the instrument that captures the acoustic expression is the properties of the piano, its sound aura. So, the inexhaustible wealth of sound and color is the nature of Nadim Norkhodjayev's music and the uniqueness of the composer's piano style.

### **Analysis and Results**

The musical works written for the perfect piano instrument, which has a history of three centuries, are the result of the creative research of European composers. During this period, a number of musical genres emerged in European music art, which are unique to the performance of the piano instrument. Each of these genres has its own form, content, dramaturgy and, of course, an artistic idea. In particular, from simple piano pieces to large-scale concert genres, they are created by composers and performed with love by performers. These works have already been recorded in the pages of history.

In the world of Uzbek music and art, the piano music performance covers a period of a quarter of a century. It is the performance of this instrument that has undergone a fantastic process of development during the current short period, and Uzbek composers have managed to create musical samples polished in the polish of mature and perfect Uzbek spiritual, national melodies, which can match the great monumental piano works of Europe. Nadim Norkhodjayev's contribution to the creation of such masterpieces is huge. Below are excerpts from Nadim Norkhodjayev's works [9-12]:

## “Olmacha anor”

*Adapted for piano*

**Moderato**



It is known that the creation of mature works that fully meet the requirements of the time is growing day by day. Nadim Norkhodjayev, a well-known composer of our time, has been prolific in his work, and has already earned his deserved creative place not only in our independent Uzbekistan, but also on a global scale. N. Norkhodjayev popular songs, the composer became known as an excellent professional composer. The artist's works created specifically for the piano genre are prolific and differ from the works of other composers due to the originality and folkiness of his artistic and



musical ideas in various genres and styles. The composer's works have been performed not only in Uzbekistan, but also in the world of art as part of a number of music competitions and festivals.

## Conclusions

In conclusion, we would not be wrong to say that the great composer, composer and creator of good genres Nadim Norkhodjayev made a great contribution to Uzbek piano composition. While studying the precious works of the writer, we can see traces of not only Uzbek genres but also world compositions. This means works that can compete with foreign composers. The youth of the current generation should use this rich heritage to learn and conduct research. It is not surprising that Chopin, Shakespeare, Tchaikovsky, Claude Achille and other famous composers are among the youth of Uzbekistan.

## References:

- [1] Rajabiy Y., Akbarov I., “O‘zbek xalq musiqasi tarixi”, *O‘qituvchi*, 1981.
- [2] Karimova M., Achildiyeva M., Ikromova F., “Use From Pedagogical Technologies in Music Lessons” *European scholar journal*, 2 (4), 2021, pp. 460-
- [3] Ikromova F., “The Ballet TOMARIS in the Culture of Uzbek Ballet Place Significance”, *Spectrum Journal of Innovation, Reforms and Development*, 3, 2022.
- [4] Qodirov R., “Musiqa psixologiyasi”, *Musiqqa*, -T., 2005.
- [5] Liberman Ye. Ya., “Rabota nad fortepiannoy texnikoy”. – M., *Klassika-XXI*, 2003.
- [6] Galovyans T.A., Meyke E.S., “Kompozitori i muzikovedi Uzbekistana”, – T.: 1999.
- [7] “O‘zbekiston milliy ensiklopediyasi”, O‘zME., Birinchi jild, -Tashkent, *O‘zbekiston milliy ensiklopediyasi Davlat ilmiy nashriyoti*, 2000.
- [8] Robert R., Nor Eddine B., “Jazzology” *The Encyclopedia of Jazztheory for all musicians*, p. 265.
- [9] “O‘zbekiston milliy ensiklopediyasi”, *National Encyclopedia of Uzbekistan (in Uzbek)*, Tashkent: *National Encyclopedia of Uzbekistan State Scientific Publishing House*, 2000–2005.
- [10] [www.cyberleninka.ru](http://www.cyberleninka.ru)
- [11] [www.aim.uz](http://www.aim.uz)
- [12] [www.zenodo.ru](http://www.zenodo.ru)